



# flender gear units

Zahnradgetriebe  
Gear Units  
Réducteurs à engrenages

**SIEMENS**



# Flender Gear Units

Catalog MD 20.1  
2006/2007

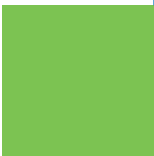
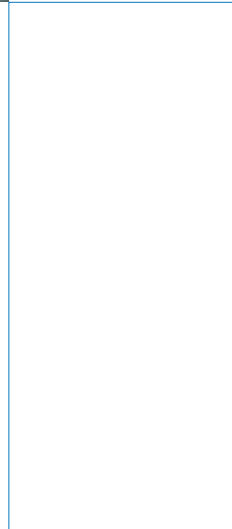

**SIEMENS**

**Charakteristische Vorzüge**  
**Characteristic features**  
**Caractéristiques**

**1**

**Allgemeine Hinweise**  
**General information**  
**Indications générales**

**2**

**Getriebeauswahl**  
**Selection of gear units**  
**Sélection de réducteurs**

**3**

**Zahnradgetriebe**  
**Gear units**  
**Réducteur à engrenages**

**4**

**Einzelheiten zu Wellen**  
**Details on shafts**  
**Détails des arbres**

**5**

**Ölversorgung**  
**Oil supply**  
**Alimentation en huile**

**6**

**Wellenabdichtungen**  
**Shaft seals**  
**Étanchéités des arbres**

**7**

**Anbauvarianten**  
**Add-on pieces**  
**Variantes de montage**

**8**

**Explosionsschutz nach ATEX 95**  
**Explosion protection according to ATEX 95**  
**Atmosphères explosives selon ATEX 95**

**9**

## Willkommen bei Automation and Drives



Willkommen in der Welt der vollständigen Integration mechanischer und elektrischer Antriebssysteme und -komponenten.

In allen Branchen und Applikationen der Industrie und der Rohstoffgewinnung sind Flender-Getriebe führend in Technologie, Qualität und Marktnähe. Totally Integrated Automation – unser durchgängiges Spektrum an Produkten, Systemen und Lösungen wird nun um diese Antriebssysteme erweitert.

Nutzen Sie die Einsparpotentiale, die Ihnen ein globaler Partner bieten kann. Tauchen Sie mit den Flender-Produkten ein in die Welt von Totally Integrated Automation.

## Welcome to Automation and Drives

Welcome to the world of the totally integrated mechanical and electrical drive systems and components!

In all industry sectors, for all industrial applications and the winning of raw materials Flender gear units are leading in technology, quality and market orientation. Totally Integrated Automation – our integrated range of products, systems and solutions is now being expanded to include these drive systems.

Utilize the savings potential which a global partner can offer you. Enter the world of Totally Integrated Automation with Flender products.

## Bienvenue chez Automation and Drives

Bienvenue dans le monde de l'intégration totale des systèmes et composants d'entraînement mécaniques et électriques.

Les réducteurs à engrenages Flender sont leaders par la technologie, la qualité et la proximité avec les marchés dans toutes les branches et applications industrielles, tout comme dans l'extraction des matières premières. Totally Integrated Automation – notre gamme extensive de produits, de systèmes et de solutions, est désormais complétée par ces systèmes d'entraînement.

Tirez profit des potentiels d'économies que peut vous offrir un partenaire mondial. Avec les produits Flender, plongez dans le monde de la Totally Integrated Automation.



Einbaulage horizontal / Horizontal mounting position / Position de montage horizontal					
<p><b>Stirnradgetriebe</b></p> <p>Bauarten H1.., H2.., H3.., H4.. 1- ... 4-stufig, <math>i_N = 1.25 - 450</math></p>		<p><b>Helical gear units</b></p> <p>Types H1.., H2.., H3.., H4.. 1- ... 4-stage, <math>i_N = 1.25 - 450</math></p>		<p><b>Réducteur à engrenages cylindriques</b></p> <p>Types H1.., H2.., H3.., H4.. 1- ... 4 étages, <math>i_N = 1.25 - 450</math></p>	
<b>H.SH</b>	<b>H.HH</b>	<b>H.DH</b>	<b>H.KH</b>	<b>H.FH</b>	<b>H.HM, H.DM, H.KM, H.FM</b>
<p><b>Kegelstirnradgetriebe</b></p> <p>Bauarten B2.., B3.., B4.. 2- ... 4-stufig, <math>i_N = 5 - 400</math></p>		<p><b>Bevel-helical gear units</b></p> <p>Types B2.., B3.., B4.. 2- ... 4-stage, <math>i_N = 5 - 400</math></p>		<p><b>Réducteurs à engrenages cylindro-coniques</b></p> <p>Types B2.., B3.., B4.. 2- ... 4 étages, <math>i_N = 5 - 400</math></p>	
<b>B.SH</b>	<b>B.HH</b>	<b>B.DH</b>	<b>B.KH</b>	<b>B.FH</b>	<b>B.HM, B.DM, B.KM, B.FM</b>
Einbaulage vertikal / Vertical mounting position / Position de montage vertical					
<p><b>Stirnradgetriebe</b></p> <p>Bauarten H2.V, H3.V, H4.V 2- ... 4-stufig, <math>i_N = 6.3 - 450</math></p>		<p><b>Helical gear units</b></p> <p>Types H2.V, H3.V, H4.V 2- ... 4-stage, <math>i_N = 6.3 - 450</math></p>		<p><b>Réducteur à engrenages cylindriques</b></p> <p>Types H2.V, H3.V, H4.V 2- ... 4 étages, <math>i_N = 6.3 - 450</math></p>	
<b>H.SV</b>	<b>H.HV</b>	<b>H.DV</b>	<b>H.KV</b>	<b>H.FV</b>	
<p><b>Kegelstirnradgetriebe</b></p> <p>Bauarten B2.V, B3.V, B4.V 2- ... 4-stufig, <math>i_N = 5 - 400</math></p>		<p><b>Bevel-helical gear units</b></p> <p>Types B2.V, B3.V, B4.V 2- ... 4-stage, <math>i_N = 5 - 400</math></p>		<p><b>Réducteur à engrenages cylindro-coniques</b></p> <p>Types B2.V, B3.V, B4.V 2- ... 4 étages, <math>i_N = 5 - 400</math></p>	
<b>B.SV</b>	<b>B.HV</b>	<b>B.DV</b>	<b>B.KV</b>	<b>B.FV</b>	

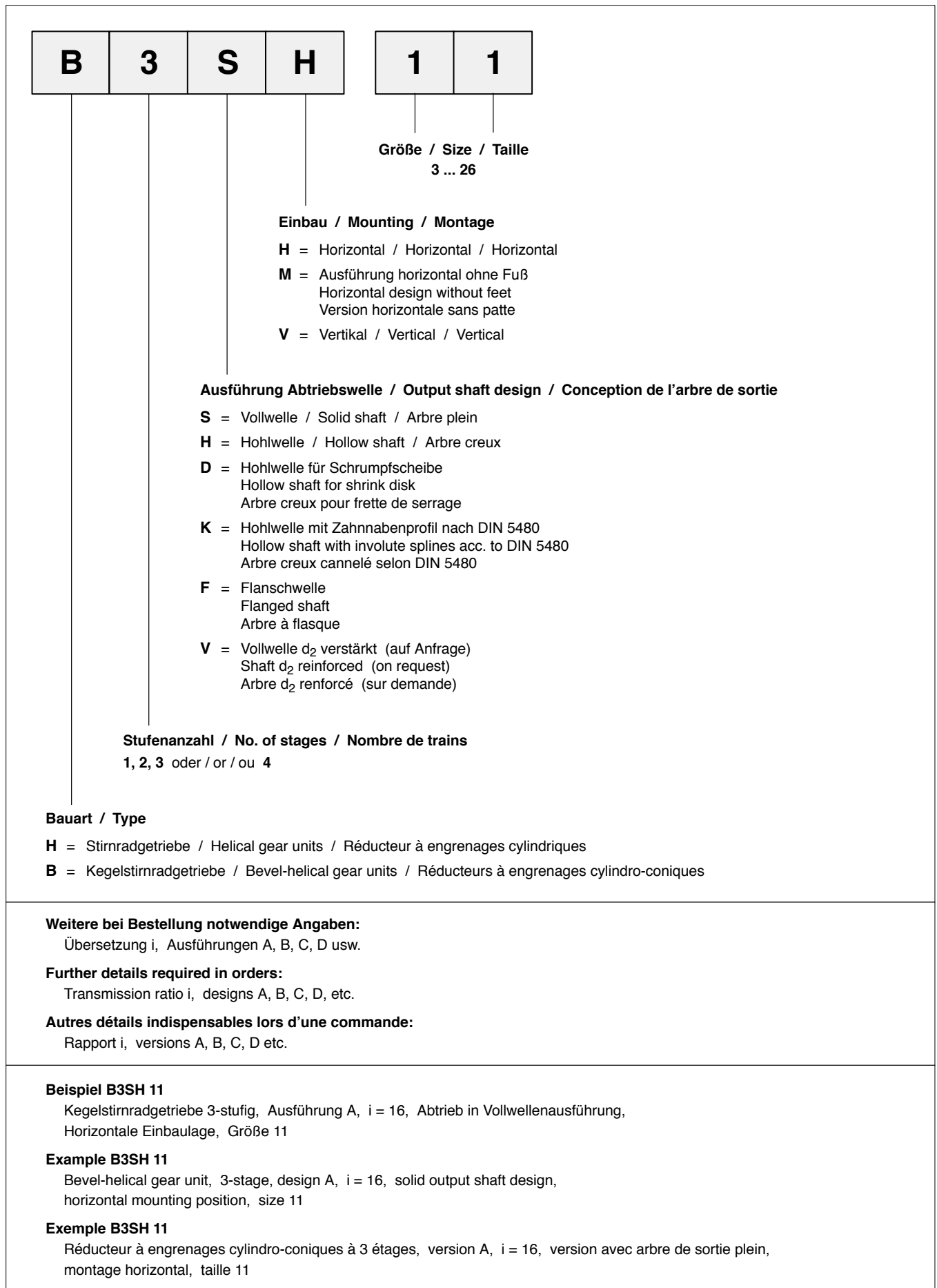

Inhalt	Contents	Sommaire	Seiten Pages
<b>Charakteristische Vorzüge</b>	<b>Characteristic features</b>	<b>Caractéristiques</b>	6
<b>Allgemeine Hinweise</b>	<b>General information</b>	<b>Indications générales</b>	7
<b>Getriebeauswahl</b>	<b>Selection of gear units</b>	<b>Sélection de réducteurs</b>	
Richtlinie bei konstanter Leistung	Guidelines, constant power rating	Directives, puissance constante	8 - 9
Richtlinie bei variabler Leistung	Guidelines, variable power rating	Directives, puissance variable	10
Erklärung der Bezeichnungen	Key to symbols	Explication des symboles	11
Beispiel	Example	Exemple	12 - 13
Betriebsfaktoren	Service factors	Facteurs de service	14 - 15
Leistungstabellen	Tables: Powers and capacities	Tableaux de puissance	
<b>H1SH</b>	<b>H1SH</b>	<b>H1SH</b>	16 - 21
<b>H2..</b>	<b>H2..</b>	<b>H2..</b>	22 - 27
<b>H3..</b>	<b>H3..</b>	<b>H3..</b>	28 - 33
<b>H4..</b>	<b>H4..</b>	<b>H4..</b>	34 - 37
<b>B2..</b>	<b>B2..</b>	<b>B2..</b>	38 - 43
<b>B3..</b>	<b>B3..</b>	<b>B3..</b>	44 - 49
<b>B4..</b>	<b>B4..</b>	<b>B4..</b>	50 - 53
Ist-Übersetzungen	Actual ratios	Rapports réels	54 - 57
Zulässige radiale Zusatzkräfte	Permissible additional radial forces	Efforts radiaux extérieurs admissibles	58 - 59
Massenträgheitsmomente $J_1$	Mass Moments of Inertia $J_1$	Moments d'inertie de masse $J_1$	60 - 63
Ausführungsformen	Assemblies	Exécutions	64 - 65
<b>Zahnradgetriebe</b>	<b>Gear units</b>	<b>Réducteur à engrenages</b>	
<b>H1SH</b>	<b>H1SH</b>	<b>H1SH</b>	66 - 67
<b>H2.H</b>	<b>H2.H</b>	<b>H2.H</b>	68 - 73
<b>H3.H</b>	<b>H3.H</b>	<b>H3.H</b>	74 - 79
<b>H4.H</b>	<b>H4.H</b>	<b>H4.H</b>	80 - 85
<b>B2.H</b>	<b>B2.H</b>	<b>B2.H</b>	86 - 89
<b>B3.H</b>	<b>B3.H</b>	<b>B3.H</b>	90 - 95
<b>B4.H</b>	<b>B4.H</b>	<b>B4.H</b>	96 - 101
<b>H2.V</b>	<b>H2.V</b>	<b>H2.V</b>	102 - 105
<b>H3.V</b>	<b>H3.V</b>	<b>H3.V</b>	106 - 109
<b>H4.V</b>	<b>H4.V</b>	<b>H4.V</b>	110 - 113
<b>B2.V</b>	<b>B2.V</b>	<b>B2.V</b>	114 - 117
<b>B3.V</b>	<b>B3.V</b>	<b>B3.V</b>	118 - 121
<b>B4.V</b>	<b>B4.V</b>	<b>B4.V</b>	122 - 125
<b>Einzelheiten zu Wellen</b>	<b>Details on shafts</b>	<b>Détails des arbres</b>	
Zentrierbohrungen	Centre holes	Centrage	126
Schutzhauben für Vollwellen	Protective covers for solid shafts	Capot de protection pour arbre plein	126
Paßfedern / Paßfedernuten	Parallel keys and keyways	Clavettes parallèles et rainures	127
Hohlwellen für Schrumpfscheiben	Hollow shafts for shrink disks	Arbre creux pour frette de serrage	128 - 129
Hohlwellen für Paßfeder- verbindungen	Hollow shafts for parallel key connections	Arbre creux pour raccord de clavette	130 - 131
Hohlwelle mit Zahnradprofil nach DIN 5480	Hollow shaft with involute splines acc. to DIN 5480	Arbre creux cannelé selon DIN 5480	132 - 133
Gegenflansche für Flanschwellen	Counterflanges for flanged shafts	Conte-bride pour arbre à bride	134 - 135



Inhalt	Contents	Sommaire	Seiten Pages
<b>Ölversorgung</b>	<b>Oil supply</b>	<b>Alimentation en huile</b>	
Ölauswahl	Selection of oil	Sélection du type d'huile	136
Konservierung	Preservation	Conservation	136
Variantenübersicht	Survey of variants	Aperçu des variantes	137
vertikal: Tauchschmierung	Vertical: Dip lubrication	vertical: Lubrification par barbotage	138
vertikal: Druckschmierung Flanschpumpe	Vertical: Forced lubrication Flanged-on pump	vertical: Lubrification sous pression Pompe flasquée	139 - 140
vertikal: Druckschmierung Motorpumpe	Vertical: Forced lubrication Motor pump	vertical: Lubrification sous pression Motopompe	141
vertikal: Druckschmierung Überwachungsgeräte	Vertical: Forced lubrication Monitoring instruments	vertical: Lubrification sous pression Dispositifs de contrôle	142
horizontal: Druckschmierung	Horizontal: Forced lubrication	horizontal: Lubrification sous pression	143 - 145
<b>zusätzliche Ölkühlung</b>	<b>Additional oil cooler</b>	<b>Refroidissement d'huile supplé- mentaire</b>	
Wasser-Ölkühler	Water-oil cooler	Refroidisseur d'huile-eau	146 - 149
Luft-Ölkühler	Air-oil cooler	Refroidisseur d'huile-air	150 - 155
Heizstäbe	Heating elements	Cannes de préchauffage	156
Öltemperaturmessung	Thermometer for oil temperature	Mesure de la température de l'huile	157
<b>Wellenabdichtungen</b>	<b>Shaft seals</b>	<b>Etanchéités des arbres</b>	158 - 160
<b>Anbauvarianten</b>	<b>Add-on pieces</b>	<b>Variantes de montage</b>	
Motorlaterne für IEC-Motoren	Motor bell housing for IEC motors	Lanterne moteur pour moteur IEC	
Motorflansch	Motor flange	Bride moteur	161
mit BIPEX-Kupplung	with BIPEX coupling	avec accouplement BIPEX	162 - 173
mit N-EUPEX-Kupplung	with N-EUPEX coupling	avec accouplement N-EUPEX	174 - 185
Schwingungsdämpfende Drehmo- mentstütze für Getriebegehäuse	Vibration reducing torque support for gear housing	Amortissement de vibrations par supports de couple pour carters de réducteur	186 - 187
<b>Getriebeschwingen</b>	<b>Gear unit swing-bases</b>	<b>Châssis supports</b>	
mit N-EUPEX-Kupplung	with N-EUPEX coupling	avec accouplement N-EUPEX	188 - 194
mit FLUDEX-Kupplung	with FLUDEX coupling	avec coupleur FLUDEX	195 - 101
<b>Sondereinbaulagen</b>	<b>Special mounting positions</b>	<b>Positions de montage particulières</b>	
Einbaulagen	Mounting positions	Positions de montage	202
Getriebefußleisten	Housing base rails	Pattes amovibles	203
Wasserschneckenausführung	Water screw design	pour vis de relevage des eaux	204 - 205
Motorstuhl	Motor bracket	Châssis support moteur	206 - 213
<b>Gehäuseflansch</b>	<b>Housing flange</b>	<b>Bride carter</b>	
Kragenflansch	Mounting flange - long spacer	Bride surélevée	214 - 215
Blockflansch	Mounting flange - short spacer	Bride	216 - 217
<b>Explosionsschutz nach ATEX 95</b>	<b>Explosion protection according to ATEX 95</b>	<b>Atmosphères explosives selon ATEX 95</b>	218
<b>Zahnradgetriebe Tochterprogramme</b>	<b>Gear units Subranges</b>	<b>Réducteurs à engrenages programmes secondaires</b>	219

## Zahnradgetriebe

### Charakteristische Vorzüge

#### Konstruktion

FLENDER-Zahnradgetriebe wurden völlig neu konzipiert. Pluspunkte sind:

- mehr Baugrößen bei weniger Bauteilvarianten,
- höhere Betriebssicherheit bei gesteigerter Leistungsdichte,
- überwiegend berührungs- und verschleißfreie Labyrinthdichtungen möglich,
- Flanschabtriebswellen zur leichteren Getriebemontage bei kleinem Raumbedarf (auf Anfrage).

#### Einbaulage

FLENDER-Zahnradgetriebe sind für horizontale und vertikale Einbaulage lieferbar. Auch andere Anordnungen sind nach Rücksprache möglich.

Das Grundgetriebe kann durch unterschiedliche Anbauteile wie z.B. Motorlaternen, Getriebschwingen oder Rücklaufsperrern optimal an die Kundenanforderungen angepaßt werden.

#### Geräuschverhalten

Bei FLENDER-Zahnradgetrieben konnte das Geräuschverhalten entscheidend verbessert werden. Dazu wurden:

- die Kegelräder geschliffen,
- die geräuschdämpfenden Gehäuse mit MASAK-Rechenprogramm entwickelt und
- außergewöhnlich hohe Überdeckungsgrade der Verzahnung erreicht.

#### Temperaturverhalten

FLENDER-Zahnradgetriebe haben bei einem guten Wirkungsgrad ein günstiges Temperaturverhalten, weil

- die Gehäuseoberflächen vergrößert wurden,
- überwiegend berührungsfreie Labyrinthdichtungen eingesetzt werden können und
- große Lüfter mit einem neu entwickelten Luftleitsystem zur Anwendung kommen.

Bei der Getriebeauswahl legt Flender eine niedrige maximale Öltemperatur zugrunde. Die Betriebssicherheit wird dadurch erhöht, und der Wartungsaufwand verringert sich durch längere Ölstandszeiten.

#### Vorratshaltung

FLENDER-Zahnradgetriebe sind nach einem neuen Baukastensystem konstruiert. Dadurch konnte die Zahl der Bauteilvarianten reduziert werden. Die Bauteile sind zum größten Teil auf Lager, so daß Flender-Produktionsstätten weltweit kurze Lieferzeiten bieten können.

## Gear Units

### Characteristic Features

#### Design

FLENDER gear units are a completely new design. Advantages are:

- more sizes with a reduced variety of parts;
- higher operational reliability combined with increased power capacity;
- predominantly non-contacting wear-resistant labyrinth seals are possible;
- flanged output shafts to facilitate assembly of gear units in confined spaces (on request).

#### Mounting position

FLENDER gear units can be supplied for either horizontal or vertical installation. Other arrangements are also possible on request.

The basic gear unit can be optimally adapted to customer requirements by fitting different add-on pieces like motor bell housings, gear unit swing-bases or backstops.

#### Noise behaviour

New concepts were applied to clearly improve the noise emission of the gear units by

- grinding the bevel gears;
- designing noise-absorbing housings by means of the MASAK computing program; and
- achieving exceptionally large contact ratios.

#### Thermal conduction

FLENDER gear units not only have a high efficiency but also a favourable thermal conduction

- through enlarged housing surface areas;
- because non-contacting labyrinth seals can be used; and
- because large fans incorporating a new type of air conduction fan cowl are being used.

The selection of FLENDER gear units is based on a lower maximum oil temperature. By that, the operational reliability will be increased and the cost of maintenance reduced due to longer oil change intervals.

#### Storing

FLENDER gear units have been designed according to a new unit construction principle. Through this, the variety of parts could be reduced. The parts are mainly on stock enabling the Flender manufacturing plants worldwide to deliver at short term.

## Réducteurs à engrenages

### Caractéristiques

#### Conception

Les réducteurs à engrenages FLENDER ont été totalement repensés. Les avantages qui en résultent sont les suivants:

- une gamme plus large: le nombre de composant a été réduit,
- une plus grande sûreté de fonctionnement: la capacité de puissance a été augmentée,
- une étanchéité assurée par des joints labyrinthés sans contact et sans usure est possible
- le montage des brides d'arbres de sortie sont plus facile (sur demande).

#### Position de montage

Les réducteurs à engrenages FLENDER sont livrables pour un montage en position horizontale ou verticale.

Vous pouvez nous consulter pour d'autres positions de montage: d'autres possibilités existent. Les lanternes de moteur, les bielles ainsi que les anti-dévireurs sont des équipements de série.

#### Niveau de bruit

Le niveau de bruit des réducteurs à engrenages FLENDER pouvait sensiblement être amélioré. C'est pourquoi nous avons:

- rectifié les engrenages coniques,
- développé l'absorption des carters à l'aide du programme de calcul MASAK,
- atteint un rapport de conduite exceptionnel.

#### Résistance à l'échauffement

Grâce à leur bon rendement, les réducteurs à engrenages FLENDER ont un échauffement minimisé. En effet:

- les surfaces de carter ont été agrandies,
- les joints sont libérés de tout frottement,
- le système de ventilation puissant, nouvellement conçu.

Lors du choix du réducteur, Flender définit une température d'huile maximale plus basse. La sûreté de fonctionnement est ainsi accrue et l'entretien diminué (l'huile dure plus longtemps).

#### Stockage

Les réducteurs à engrenages FLENDER ont été conçus selon un nouveau système de montage avec des éléments standardisés. C'est ainsi que l'on a pu réduire le nombre de composants. Les composants sont pour la plupart en stock, si bien que les centres de production Flender du monde entier peuvent proposer des délais de livraison courts.

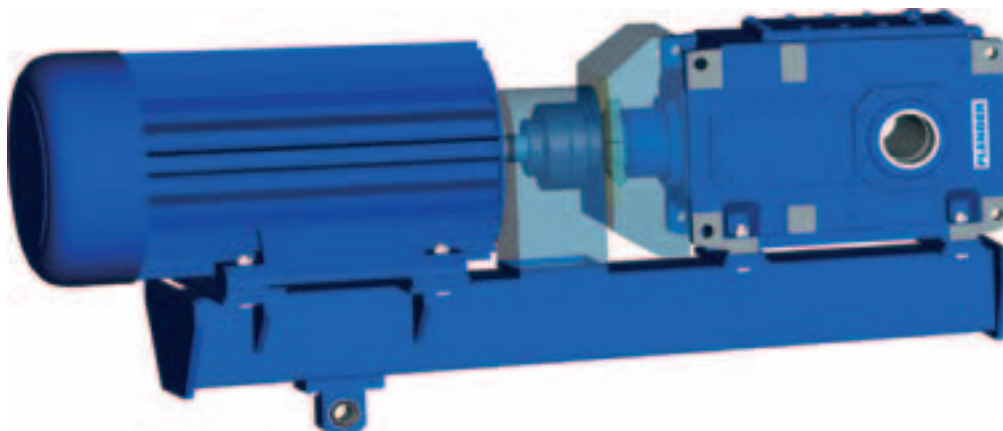

FLENDER-Kegelstirradgetriebe Bauart B3DH mit Lüfter und Getriebschwinge

FLENDER bevel-helical gear unit type B3DH with fan and gear unit swing-base





FLENDER Réducteur à engrenages cylindro-coniques, type B3DH avec ventilateur et châssis support pour réducteur

### **Achtung!**

Folgende Punkte sind unbedingt zu beachten!

- Abbildungen sind beispielhaft und nicht verbindlich. Maßänderungen bleiben vorbehalten.
- Die angegebenen Gewichte sind unverbindliche Mittelwerte.
- Umlaufende Teile müssen vom Käufer gegen unbeabsichtigtes Berühren geschützt werden. Die gültigen Sicherheitsbestimmungen des jeweiligen Einsatzlandes sind zu beachten.
- Vor Inbetriebnahme ist die Betriebsanleitung zu beachten. Die Getriebe werden betriebsfertig, jedoch ohne Ölfüllung geliefert.
- Ölmenangaben sind unverbindliche Richtwerte. Maßgebend ist die Ölstandsmarkierung am Ölmeßstab.
- Ölviskosität muß den Angaben des Typenschildes entsprechen.
- Es dürfen nur freigegebene Schmierstoffe verwendet werden. Aktuelle Betriebsanleitungen und Schmierstofftabellen finden Sie auf unserer Homepage unter: [www.flender.com](http://www.flender.com)
- Die Getriebe werden mit Radialwellendichtringen ausgeliefert. Andere Dichtungsvarianten auf Anfrage.
- Drehrichtungsangaben beziehen sich auf die Abtriebswelle d<sub>2</sub>.
- Bei Aufstellung im Freien ist Sonnenbestrahlung zu vermeiden. Entsprechende Schutzeinrichtungen sind kundenseitig vorzusehen.

Erklärung der Symbole in den Maßzeichnungen:

-  = Ölmeßstab
-  = Entlüftung
-  = Ölablaß
-  = Öleinfüllung

Ab Getriebegröße 13 Druckschrauben im Gehäusefuß und Ausrichtflächen auf dem Oberteil des Gehäuses.





Fußschrauben mit Mindest-Festigkeitsklasse 8.8. Toleranz der Befestigungsbohrungen im Gehäuse nach DIN EN 20273 – Reihe "grob". Die Getriebe sind konserviert und im Farbton RAL 5015 lackiert.

### **Attention!**

The following items are absolutely to be observed!

- Illustrations are examples only and are not strictly binding. Dimensions are subject to change.
- The weights are mean values and not strictly binding.
- To prevent accidents, all rotating parts should be guarded according to local and national safety regulations.
- Prior to commissioning, the operating instructions must be observed. The gear units are delivered ready for operation but without oil filling.
- Oil quantities given are guide values only. The exact quantity of oil depends on the marks on the oil dipstick.
- The oil viscosity has to correspond to the data given on the name plate.
- Permitted lubricants may be used only. You will find current operating instructions and lubricant selection tables on our home page at: [www.flender.com](http://www.flender.com)
- The gear units are supplied with radial shaft seals. Other sealing variants on request.
- Directions of rotation referring to output shaft d<sub>2</sub>.
- In case of outdoor installation, insulation is to be avoided. The customer has to provide adequate protection.

Explanation of symbols used in the dimensioned drawings:

-  = Oil dipstick
-  = Breather
-  = Oil drain
-  = Oil filler

From size 13 up jack screws in the housing feet, and leveling pads on the upper housing part.





Foundation bolts of min. property class 8.8. Tolerance of the clearance holes in the housing acc. to DIN EN 20273 – "coarse" series. The gear housings are protected against corrosion and sprayed in RAL 5015.

### **Attention!**

Les points suivants doivent impérativement être respectés!

- Les schémas sont donnés à titre indicatif, sans engagement. Nous nous réservons le droit de modifier les cotes que nous donnons.
- Les poids sont des valeurs indicatives.
- L'acheteur s'engage à protéger les pièces rotatives contre tout contact accidentel. Les consignes de sécurité en vigueur dans chaque pays d'utilisation doivent être respectées.
- Avant la mise en service, lire attentivement les instructions de service. Les réducteurs sont livrés finis de fabrication mais sans huile.
- Les quantités d'huile données sont des valeurs indicatives sans engagement. La quantité d'huile exacte dépend des marques sur la jauge de niveau d'huile.
- La viscosité de l'huile doit être conforme aux indications de la plaque signalétique.
- Seules les lubrifiants homologués sont autorisés. Vous trouverez nos manuels d'utilisation en vigueur avec les tableaux des lubrifiants recommandés sur notre site internet: [www.flender.com](http://www.flender.com)
- Les réducteurs sont équipés de bagues d'étanchéité. D'autres types d'étanchéité sur demande.
- Le sens de rotation se détermine en se référant à l'arbre de sortie d<sub>2</sub>.
- En utilisation extérieure l'exposition au soleil doit être évitée. Le client doit prévoir les protections adéquates.

Explication des symboles utilisés pour les mesures:

-  = Jauge de niveau d'huile
-  = Purge d'air
-  = Vidange d'huile
-  = Tubulure de versement d'huile

A partir de la taille 13, des vis de serrage sont prévues dans les pieds du carter et des faces de références sont prévues sur la partie supérieure du carter.

Vis de fixation en classe min. 8.8. Tolérance des alésages de fixation dans le carter selon DIN EN 20273 – série "gros". Leurs carters reçoivent un traitement anti-corrosion et sont peints en RAL 5015.

Richtlinien für die Auswahl  
Konstante Leistung  
mechanisch

Guidelines for the Selection  
Constant Mechanical Power  
Rating

Directives de sélection  
Puissance constante  
mécanique

3

<p><b>1. Bestimmung von Getriebebauart und Größe</b>  <b>Determination of gear unit type and size</b>  <b>Détermination du type et de la taille du réducteur</b></p>	<p>1.1 Bestimmung der Übersetzung Find the transmission ratio Détermination du rapport</p> $i_s = \frac{n_1}{n_2}$ <p>1.2 Bestimmung der Getriebeennleistung Determine nominal power rating of the gear unit Détermination de la puissance nominale du réducteur</p> $P_{2N} \geq P_2 \times f_1 \times f_2$ <p>Rücksprache nicht erforderlich, wenn: It is not necessary to consult us, if: Demande n'est pas nécessaire si:</p> $3.33 \times P_2 \geq P_{2N}$ <p>1.3 Kontrolle auf Maximalmoment z.B.: Betriebsspitzen-, Anfahr- oder Bremsmoment Check for maximum torque, e. g. peak operating-, starting- or braking torque Contrôle du couple maximal, par ex.: pointes de fonctionnement, couple de démarrage ou de freinage</p> $P_{2N} \geq \frac{T_A \times n_1}{9550} \times f_3$ <p>Getriebegrößen und Stufenanzahl sind in den Leistungstabellen abhängig von <math>i_N</math> und <math>P_{2N}</math> festgelegt Gear unit sizes and number of reduction stages are given in rating tables depending on <math>i_N</math> and <math>P_{2N}</math> Les tailles des réducteurs et le nombre d'étages donnés dans les tableaux de puissance dépendent de <math>i_N</math> et de <math>P_{2N}</math></p> <p>1.4 Prüfung der Zulässigkeit von Zusatzkräften auf die Abtriebswelle; siehe Seiten 58 und 59 Check whether additional forces on the output shaft are permissible; see pages 58 and 59 Vérification des efforts supplémentaires admissibles sur l'arbre de sortie; pages 58 et 59</p> <p>1.5 Prüfung, ob Ist-Übersetzung <math>i</math> geeignet ist, siehe Seiten 54 - 57 Check whether the actual ratio <math>i</math> as per tables on pages 54 - 57 is acceptable Pour vérifier si le rapport réel est approprié, se reporter aux tableaux des pages 54 - 57</p>			
	<p><b>Einbaulage / Mounting position / Position de montage</b></p> <table border="1" style="width: 100%; border-collapse: collapse;"> <tr> <td style="width: 50%; text-align: center;"><b>Horizontal / Horizontal / Horizontale</b></td> <td style="width: 50%; text-align: center;"><b>Vertikal / Vertical / Verticale</b></td> </tr> </table>		<b>Horizontal / Horizontal / Horizontale</b>	<b>Vertikal / Vertical / Verticale</b>
<b>Horizontal / Horizontal / Horizontale</b>	<b>Vertikal / Vertical / Verticale</b>			
<p><b>2. Bestimmung der Ölversorgung</b>  <b>Determination of oil supply</b>  <b>Détermination de lubrification</b></p>	<table border="1" style="width: 100%; border-collapse: collapse;"> <tr> <td style="width: 50%; vertical-align: top;"> <p>Alle zu schmierenden Elemente liegen im Öl bzw. werden mit Spritzöl versorgt Druckschmierung auf Anfrage All parts to be lubricated are lying in the oil or are splash lubricated Forced lubrication on request Toutes les parties à lubrifier sont en barbotage dans l'huile ou lubrifiées par pression</p> </td> <td style="width: 50%; vertical-align: top;"> <p>Mögliche Ölversorgungsvarianten: – Tauchschmierung – Druckschmierung mittels Flansch- oder Motorpumpe Vorzugsvarianten und Auswahlkriterien siehe Seiten 136 - 157 Possible oil supply variations: – Dip lubrication – Forced lubrication by means of flanged-on pump or motor pump For preferred variants and criteria for selection, see pages 136 - 157 Type de lubrification possible: – Lubrification par barbotage – Lubrification forcée par pompe attelée ou groupe motopompe Variantes et critères de sélection, voir pages 136 - 157</p> </td> </tr> </table>		<p>Alle zu schmierenden Elemente liegen im Öl bzw. werden mit Spritzöl versorgt Druckschmierung auf Anfrage All parts to be lubricated are lying in the oil or are splash lubricated Forced lubrication on request Toutes les parties à lubrifier sont en barbotage dans l'huile ou lubrifiées par pression</p>	<p>Mögliche Ölversorgungsvarianten: – Tauchschmierung – Druckschmierung mittels Flansch- oder Motorpumpe Vorzugsvarianten und Auswahlkriterien siehe Seiten 136 - 157 Possible oil supply variations: – Dip lubrication – Forced lubrication by means of flanged-on pump or motor pump For preferred variants and criteria for selection, see pages 136 - 157 Type de lubrification possible: – Lubrification par barbotage – Lubrification forcée par pompe attelée ou groupe motopompe Variantes et critères de sélection, voir pages 136 - 157</p>
<p>Alle zu schmierenden Elemente liegen im Öl bzw. werden mit Spritzöl versorgt Druckschmierung auf Anfrage All parts to be lubricated are lying in the oil or are splash lubricated Forced lubrication on request Toutes les parties à lubrifier sont en barbotage dans l'huile ou lubrifiées par pression</p>	<p>Mögliche Ölversorgungsvarianten: – Tauchschmierung – Druckschmierung mittels Flansch- oder Motorpumpe Vorzugsvarianten und Auswahlkriterien siehe Seiten 136 - 157 Possible oil supply variations: – Dip lubrication – Forced lubrication by means of flanged-on pump or motor pump For preferred variants and criteria for selection, see pages 136 - 157 Type de lubrification possible: – Lubrification par barbotage – Lubrification forcée par pompe attelée ou groupe motopompe Variantes et critères de sélection, voir pages 136 - 157</p>			

Richtlinien für die Auswahl  
Konstante Leistung  
thermisch

Guidelines for the Selection  
Thermal Capacities

Directives de sélection  
Puissance constante  
thermique

### 3. Bestimmung der erforderlichen Wärmegrenzleistungen $P_G$

#### Notwendige Daten:

- Bauart • Größe • Nennübersetzung
- Umgebungstemperatur
- Antriebsdrehzahl (1000 / 1200 / 1500 / 1800 min<sup>-1</sup>)
- Getriebe mit Tauchschmierung

#### Für die nachfolgende Rechnung gelten folgende Annahmen:

- Einschaltdauer: 100 %
- Aufstellung in großer Halle (Windgeschwindigkeit  $\geq 1,4$  m/s), Höhenlage bis 1000 m
- Getriebe mit Mineralöl ISO-VG460

### 3. Determination of required thermal capacity $P_G$

#### Data required:

- Type • Size • Nominal ratio
- Ambient temperature
- Input speed (1000 / 1200 / 1500 / 1800 min<sup>-1</sup>)
- Gear unit with dip lubrication

#### For the calculation below the following has been assumed:

- Operating cycle: 100 %
- Installation in a large hall (wind velocity  $\geq 1.4$  m/s), altitude up to 1000 m
- Gear unit with mineral oil ISO-VG460

### 3. Détermination de la capacité thermique nécessaire $P_G$

#### Données nécessaires:

- Type • Taille • Rapport nominal
- Température ambiante
- Vitesse d'entrée (1000 / 1200 / 1500 / 1800 min<sup>-1</sup>)
- Réducteurs avec lubrification par barbotage

#### Les hypothèses suivantes sont prises en considération pour le calcul:

- Durée d'utilisation: 100 %
- Implantation dans un grand hall (Vitesse du vent  $\geq 1,4$  m/s), Altitude jusqu'à 1000 m
- Réducteurs avec huile minérale ISO-VG460

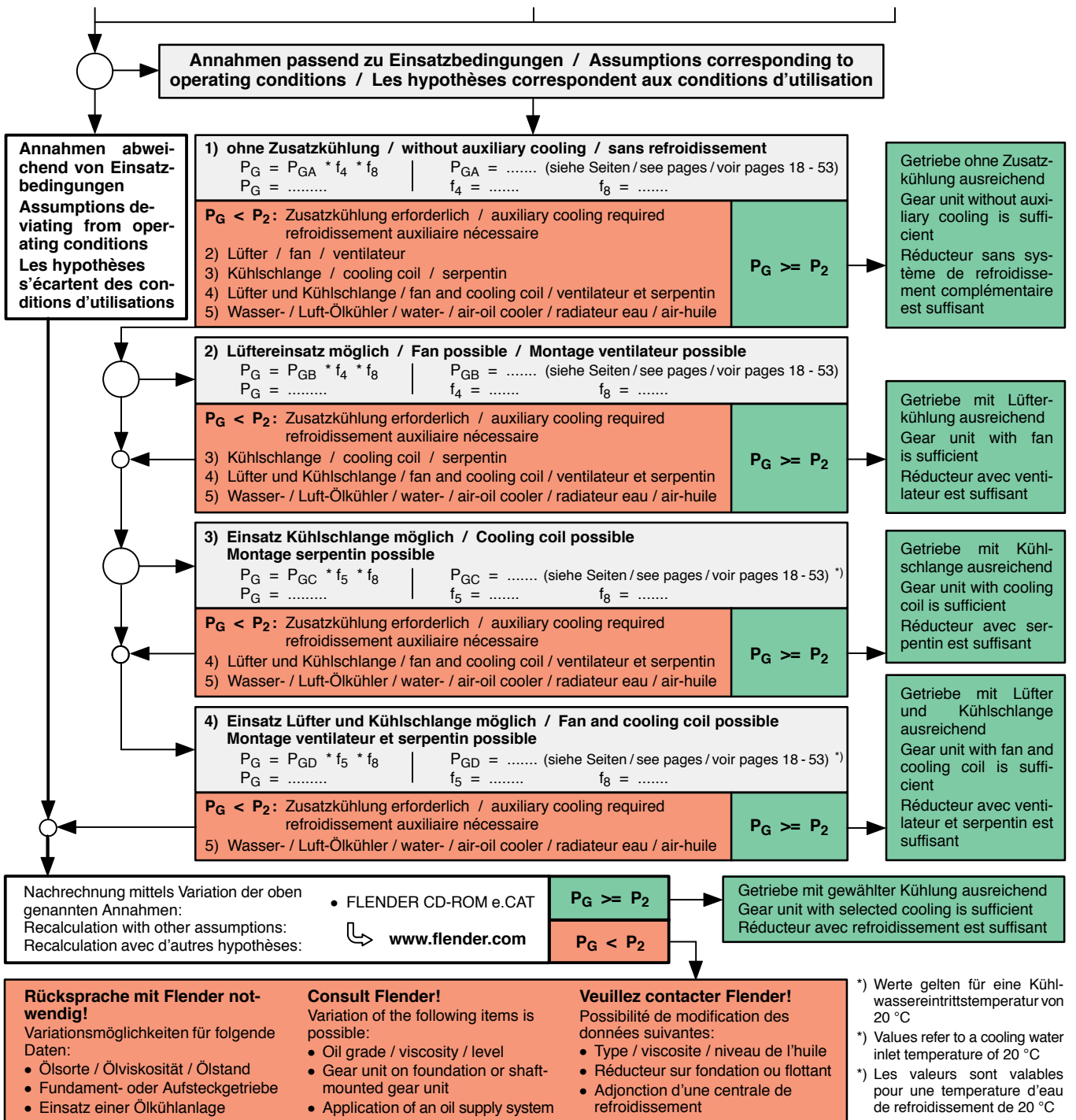

## Richtlinien für die Auswahl Variable Leistung

## Guidelines for the Selection Variable Power Rating

## Directives de sélection Puissance variable

Für Arbeitsmaschinen mit konstanten Drehzahlen und variablen Leistungen kann das Getriebe nach der sogenannten äquivalenten Leistung ausgelegt werden. Dabei wird ein Arbeitszyklus zugrunde gelegt, dessen Phasen I, II...n die Leistungen  $P_I, P_{II}...P_n$  erfordern, wobei die jeweiligen Leistungen den prozentualen Zeitanteil  $X_I, X_{II}...X_n$  haben. Mit diesen Angaben wird die äquivalente Leistung nach folgender Formel berechnet:

For driven machines with constant speeds and variable power ratings the gear unit can be designed according to the equivalent power rating. For this, a working cycle where phases I, II...n require power  $P_I, P_{II}...P_n$  and the respective power ratings operate for time fractions  $X_I, X_{II}...X_n$  is taken as a basis. The equivalent power rating can be calculated from these specifications with the following formula:

En présence de machines entraînées à une vitesse constante mais avec des puissances variables, nous pouvons sélectionner le réducteur en fonction de la puissance équivalente. En pareil cas nous partons d'un cycle de charge dont les phases I, II...n exigent les puissances  $P_I, P_{II}...P_n$ , chaque puissance ayant une tranche de temps  $X_I, X_{II}...X_n$  exprimée en %. En vertu de ces indications, nous calculons la puissance à l'aide de la formule suivante:

$$P_{2\text{äq}} = \sqrt[6.6]{P_I^{6.6} \times \frac{X_I}{100} + P_{II}^{6.6} \times \frac{X_{II}}{100} + \dots + P_n^{6.6} \times \frac{X_n}{100}}$$

Die Bestimmung der Getriebegröße erfolgt dann analog den Punkten 1.1 ... 1.5 und 3.

The size of the gear unit can then be determined analogously to points 1.1 ... 1.5 and 3.

Nous déterminons ensuite la taille du réducteur de manière analogue au contenu des section 1.1 à 1.5 et 3.

Dabei gilt:

as follows:

Ce faisant, nous tenons compte de la formule suivante:

$$P_{2N} \geq P_{2\text{äq}} \times f_1 \times f_2$$

Anschließend, nachdem  $P_{2N}$  bestimmt wurde, sind die Leistungs- und Zeitanteile nach folgenden Bedingungen zu prüfen.

Then, when  $P_{2N}$  has been determined, the power and time fractions must be checked by applying the following requirements:

Ensuite, une fois  $P_{2N}$  déterminé, il faut vérifier les tranches de puissance et de temps en fonction des conditions suivantes:

- 1) Die einzelnen Leistungsanteile  $P_I, P_{II}...P_n$  müssen größer  $0,4 \times P_{2N}$  sein.
- 2) Die einzelnen Leistungsanteile  $P_I, P_{II}...P_n$  dürfen  $1,4 \times P_{2N}$  nicht überschreiten.
- 3) Bei den Leistungsanteilen  $P_I, P_{II}...P_n$ , die größer als  $P_{2N}$  sind, darf die Summe der Zeitanteile  $X_I, X_{II}...X_n$  maximal 10% betragen.

- 1) The individual power fractions  $P_I, P_{II}...P_n$  must be greater than  $0.4 \times P_{2N}$ .
- 2) The individual power fractions  $P_I, P_{II}...P_n$  must not exceed  $1.4 \times P_{2N}$ .
- 3) If power fractions  $P_I, P_{II}...P_n$  are greater than  $P_{2N}$ , the sum of time fractions  $X_I, X_{II}...X_n$  must not exceed 10%.

- 1) Les différentes tranches de puissance  $P_I, P_{II}...P_n$  doivent être supérieures à  $0,4 \times P_{2N}$ .
- 2) Les différentes tranches de puissance  $P_I, P_{II}...P_n$  ne doivent pas dépasser  $1,4 \times P_{2N}$ .
- 3) Lorsque les tranches de puissance  $P_I, P_{II}...P_n$  sont supérieures à  $P_{2N}$ , la somme de tranches de temps  $X_I, X_{II}...X_n$  ne doit pas dépasser 10%.

Falls eine der drei Bedingungen nicht erfüllt wird, so ist eine erneute Berechnung von  $P_{2\text{äq}}$  notwendig.

If any one of the three requirements is not met,  $P_{2\text{äq}}$  must be recalculated.

Si l'une des trois conditions susmentionnées n'est pas satisfaite, il faut recalculer  $P_{2\text{äq}}$ .

Grundsätzlich ist zu berücksichtigen, daß eine kurzzeitige Spitzenleistung, die nicht bei der Ermittlung von  $P_{2\text{äq}}$  erfaßt wird, nicht größer als  $P_{\text{max}} = 2 \times P_{2N}$  sein darf.

It must be borne in mind that a brief peak power rating not included in the calculation of  $P_{2\text{äq}}$  must not be greater than  $P_{\text{max}} = 2 \times P_{2N}$ .

Se rappeler d'une manière fondamentale qu'une brève crête de puissance non prise en compte lors de la détermination de  $P_{2\text{äq}}$  ne doit pas dépasser  $P_{\text{max}} = 2 \times P_{2N}$ .

In Einsatzfällen mit **variablen Drehmomenten** aber **konstanter Drehzahl** erfolgt die Getriebeauslegung auf der Basis des sogenannten **äquivalenten Drehmomentes**.

In applications where the **torque is variable** but the **speed constant** the gear unit can be designed on the basis of the so-called **equivalent torque**.

Dans les cas d'application présentant des **couples variables** mais à **vitesse constante**, le réducteur est calculé sur la base du **couple équivalent**.

Für bestimmte Anwendungen kann eine **zeitfeste Auslegung** des Getriebes ausreichend sein. Dazu gehören zum Beispiel sporadischer Einsatz (Schleusenantriebe) oder geringe Abtriebsdrehzahlen ( $n_2 < 4 \text{ min}^{-1}$ ).

A gear unit design which is **finite-life fatigue-resistant** can be sufficient for certain applications, for example, sporadic operation (lock-gate drives) or slow output speeds ( $n_2 < 4 \text{ min}^{-1}$ ).

Dans certaines applications, il pourra suffire que le réducteur soit **conçu résistant pendant une période déterminée**. Parmi elles figurent les utilisations sporadiques (fonctionnement des écluses) ou celles à faibles vitesses de sortie ( $n_2 < 4 \text{ min}^{-1}$ ).

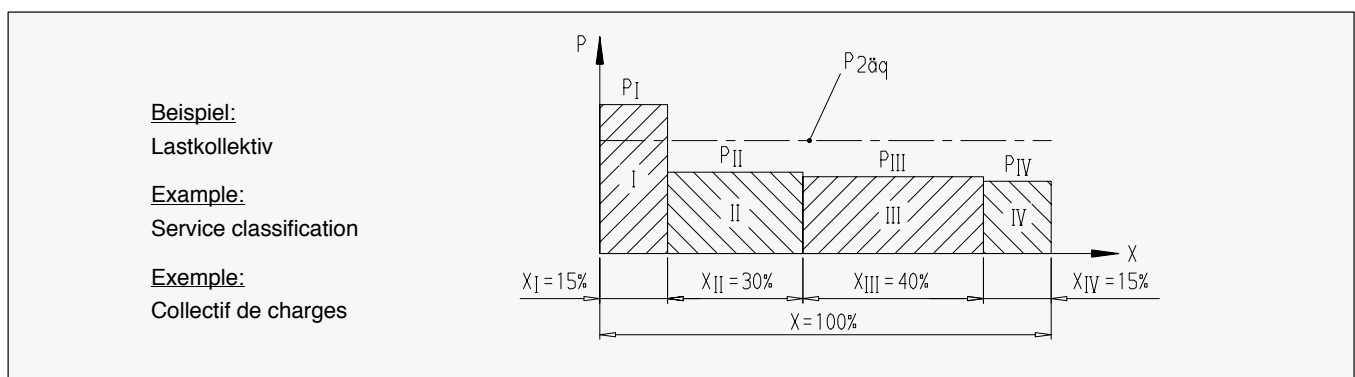

Erklärung der Bezeichnungen:	Key to symbols:	Explication des symboles:
$E_D$ = Einschaltdauer in % (z.B. $E_D = 80\%$ je Stunde)	$E_D$ = Operating cycle per hour in %, e.g. $E_D = 80\% / h$	$E_D$ = Durée d'utilisation en %, par ex: ( $E_D = 80\%$ par heure)
$f_1$ = Arbeitsmaschinenfaktor (Tabelle 1), Seite 14	$f_1$ = Factor for driven machine (table 1), page 14	$f_1$ = Facteur de travail des machines (tableau 1), page 14
$f_2$ = Antriebsmaschinenfaktor (Tabelle 2), Seite 15	$f_2$ = Factor for prime mover (table 2), page 15	$f_2$ = Facteur des machines motrices (tableau 2), page 15
$f_3$ = Spitzenmomentfaktor (Tabelle 3), Seite 15	$f_3$ = Peak torque factor (table 3), page 15	$f_3$ = Facteur des pointes maximales (tableau 3), page 15
$f_4$ = Wärmefaktoren (Tabelle 4), Seite 15	$f_4$ = Thermal factors (table 4), page 15	$f_4$ = Facteurs thermiques (tableau 4), page 15
$f_5$ = Wärmefaktoren (Tabelle 5), Seite 15	$f_5$ = Thermal factors (table 5), page 15	$f_5$ = Facteurs thermiques (tableau 5), page 15
$f_8$ = Ölversorgungsfaktor bei Vertikalgetrieben, (Tabelle 8), Seite 15. Bei Horizontalgetrieben: $f_8 = 1$	$f_8$ = Oil supply factor for vertical gear units (table 8), page 15. For horizontal gear units: $f_8 = 1$	$f_8$ = Facteur d'alimentation en huile pour les réducteurs verticaux (tableau 8), page 15. Pour les réducteurs horizontaux: $f_8 = 1$
$i$ = Ist-Übersetzung	$i$ = Actual ratio	$i$ = Rapport réel
$i_N$ = Nennübersetzung	$i_N$ = Nominal ratio	$i_N$ = Rapport nominal
$i_s$ = Soll-Übersetzung	$i_s$ = Required ratio	$i_s$ = Rapport théorique
$n_1$ = Antriebsdrehzahl ( $\text{min}^{-1}$ )	$n_1$ = Input speed ( $\text{min}^{-1}$ )	$n_1$ = Vitesse d'entrée ( $\text{min}^{-1}$ )
$n_2$ = Abtriebsdrehzahl ( $\text{min}^{-1}$ )	$n_2$ = Output speed ( $\text{min}^{-1}$ )	$n_2$ = Vitesse de sortie ( $\text{min}^{-1}$ )
$P_G$ = Erforderliche Wärmegrenzleistung	$P_G$ = Required thermal capacity	$P_G$ = Capacité thermique nécessaire
$P_{GA}$ = Wärmegrenzleistung für Getriebe ohne Zusatzkühlung, Seiten 18 - 53	$P_{GA}$ = Thermal capacity for gear units without auxiliary cooling, pages 18 - 53	$P_{GA}$ = Capacité thermique limite sans système de refroidissement complémentaire, pages 18 - 53
$P_{GB}$ = Wärmegrenzleistung für Getriebe mit Lüfterkühlung, Seiten 18 - 53	$P_{GB}$ = Thermal capacity for gear units with fan cooling, pages 18 - 53	$P_{GB}$ = Capacité thermique limite pour réducteurs avec refroidissement par ventilateur, pages 18 - 53
$P_{GC}$ = Wärmegrenzleistung für Getriebe mit eingebauter Kühlschlange, Seiten 18 - 53	$P_{GC}$ = Thermal capacity for gear units with built-in cooling coil, pages 18 - 53	$P_{GC}$ = Capacité thermique limite pour réducteurs avec serpentin de refroidissement, pages 18 - 53
$P_{GD}$ = Wärmegrenzleistung für Getriebe mit eingebauter Kühlschlange und Lüfter, Seiten 18 - 53	$P_{GD}$ = Thermal capacity for gear units with built-in cooling coil and fan, pages 18 - 53	$P_{GD}$ = Capacité thermique limite avec serpentin de refroidissement intégré et ventilateur, pages 18 - 53
$P_{2N}$ = Getriebennennleistung (kW), siehe Leistungstabellen Seiten 16 - 50	$P_{2N}$ = Nominal power rating of gear unit (kW), see rating tables, pages 16 - 50	$P_{2N}$ = Puissance nominale du réducteur (kW); voir tableau de puissance, pages 16 - 50
$P_2$ = Leistung der Arbeitsmaschine (kW)	$P_2$ = Power rating of driven machine (kW)	$P_2$ = Puissance de la machine de travail (kW)
$t$ = Umgebungstemperatur ( $^{\circ}\text{C}$ )	$t$ = Ambient temperature ( $^{\circ}\text{C}$ )	$t$ = Température ambiante ( $^{\circ}\text{C}$ )
$T_A$ = Max. auftretendes Drehmoment an Eingangswelle z.B.: Betriebsspitzen-, Anfahr- oder Bremsmoment (Nm)	$T_A$ = Max. torque occurring on input shaft, e.g. peak operating-, starting- or braking torque (Nm)	$T_A$ = Couple maximal à l'arbre d'entrée; par ex: pointes de fonctionnement, couple de freinage ou de démarrage (Nm)
$T_{2N}$ = Nenn-Abtriebsdrehmoment (kNm), Seiten 17 - 51	$T_{2N}$ = Nominal output torque (kNm), pages 17 - 51	$T_{2N}$ = Couple nominal de sortie (kNm), pages 17 - 51
$P_{2\text{äq}}$ = äquivalente Leistung (kW)	$P_{2\text{äq}}$ = Equivalent power rating (kW)	$P_{2\text{äq}}$ = Puissance équivalente (kW)
$P_I, P_{II}, P_n$ = Leistungsanteile (kW) aus Lastkollektiv	$P_I, P_{II}, P_n$ = Fractions of power rating (kW) obtained from service classification	$P_I, P_{II}, P_n$ = Tranches de puissance (kW) d'un collectif de charges
$X_I, X_{II}, X_n$ = Zeitanteile (%) aus Lastkollektiv	$X_I, X_{II}, X_n$ = Fractions of time (%) obtained from service classification	$X_I, X_{II}, X_n$ = Tranches de temps (%) d'un collectif de charges

## Zahnradgetriebe

## Gear Units

## Réducteurs à engrenages

Richtlinien für die Auswahl  
Berechnungsbeispiel  
mechanisch

Guidelines for the Selection  
Calculation Example  
Mechanical Power Rating

Directives de sélection  
Exemple de calcul  
mécanique

### Gegeben:

#### ANTRIEBSMASCHINE

Elektromotor:  $P_1 = 75 \text{ kW}$   
Motordrehzahl:  $n_1 = 1500 \text{ min}^{-1}$   
Max. Anfahrmoment:  $T_A = 720 \text{ Nm}$

#### ARBEITSMASCHINE

Gurtbandförderer:  $P_2 = 66 \text{ kW}$   
Drehzahl:  $n_2 = 26 \text{ min}^{-1}$   
Betriebsdauer: 12 h / Tag  
  
Anläufe je Stunde: 7  
Einschaltdauer je Stunde:  $E_D = 100\%$   
  
Umgebungstemperatur:  $30 \text{ }^\circ\text{C}$   
Aufstellung in großer Halle: Windgeschwindigkeit  $\geq 1,4 \text{ m/s}$   
Höhenlage: Meereshöhe

#### GETRIEBEAUSFÜHRUNG

Kegelstirnradgetriebe  
Einbau: horizontal  
Abtriebswelle  $d_2$ : rechts, Ausführung C Vollwelle  
  
Drehrichtung der Abtriebswelle  $d_2$ : links

### Gesucht:

Getriebebauart, Getriebegröße

#### 1. Bestimmung der Getriebebauart und Größe

1.1 Bestimmung der Übersetzung

### Known criteria:

#### PRIME MOVER

Electric motor:  $P_1 = 75 \text{ kW}$   
Motor speed:  $n_1 = 1500 \text{ min}^{-1}$   
Max. starting torque:  $T_A = 720 \text{ Nm}$

#### DRIVEN MACHINE

Belt conveyor:  $P_2 = 66 \text{ kW}$   
Speed:  $n_2 = 26 \text{ min}^{-1}$   
Duty: 12 h / day  
  
Starts per hour: 7  
Operating cycle per hour:  $E_D = 100\%$   
  
Ambient temperature:  $30 \text{ }^\circ\text{C}$   
Installation in a large hall: wind velocity  $\geq 1.4 \text{ m/s}$   
Altitude: sea level

#### GEAR UNIT DESIGN

Bevel-helical gear unit  
Mounting position: horizontal  
Output shaft  $d_2$ : on right hand side design C, solid shaft  
  
Direction of rotation of output shaft  $d_2$ : ccw

### Required:

Type and size of gear unit

#### 1. Selection of gear unit type and size

1.1 Calculation of transmission ratio

$$i_s = \frac{n_1}{n_2} = \frac{1500}{26} = 57.7 \quad i_N = 56$$

1.2 Bestimmung der Getriebeleistung

1.2 Determination of the gear unit nominal power rating

$$P_{2N} \geq P_2 \times f_1 \times f_2 = 66 \times 1.3 \times 1 = 85.8 \text{ kW}$$

Aus Leistungstabelle Bauart B3SH, Getriebegröße 9 mit  $P_{2N} = 100 \text{ kW}$  gewählt.

Selected from power rating table: type B3SH, gear unit size 9, with  $P_{2N} = 100 \text{ kW}$

Sélectionné sur le tableau de puissance: type B3SH, taille 9 avec  $P_{2N} = 100 \text{ kW}$

$$3.33 \times P_2 \geq P_{2N} \quad 3.33 \times 66 = 219.8 \text{ kW} > P_{2N} \quad \begin{array}{l} \text{Rücksprache nicht erforderlich} \\ \text{It is not necessary to consult us} \\ \text{Il n'est pas nécessaire de nous consulter} \end{array}$$

1.3 Kontrolle auf Anfahrmoment

1.3 Checking the starting torque

1.3 Contrôle du couple de démarrage

$$P_{2N} \geq \frac{T_A \times n_1}{9550} \times f_3 = \frac{720 \times 1500}{9550} \times 0.65 = 73.5 \text{ kW} \quad P_{2N} = 100 \text{ kW} > 73.5 \text{ kW}$$

#### 2. Bestimmung der Ölversorgung

Getriebe mit Tauchschrimerung

#### 2. Determination of oil supply

Gear unit with dip lubrication

#### 2. Détermination de lubrification

Réducteur avec lubrification par barbotage



# Zahnradgetriebe

# Gear Units

# Réducteurs à engrenages

Richtlinien für die Auswahl  
Berechnungsbeispiel  
thermisch

Guidelines for the Selection  
Calculation Example  
Thermal Capacity

Directives de sélection  
Exemple de calcul  
thermique

### 3. Bestimmung der erforderlichen Wärmegrenzleistungen $P_G$

#### Notwendige Daten:

- Bauart: B3SH • Größe: 09
- Nennübersetzung:  $i_N = 56$
- Umgebungstemperatur:  $t = 30\text{ °C}$
- Antriebsdrehzahl:  $n_1 = 1500\text{ min}^{-1}$
- Getriebe mit Tauchschröpfung

#### Für die nachfolgende Rechnung gelten folgende Annahmen:

- Einschaltdauer: 100 %
- Aufstellung in großer Halle (Windgeschwindigkeit  $\geq 1,4\text{ m/s}$ ), Höhenlage bis 1000 m
- Getriebe mit Mineralöl ISO-VG460

### 3. Determination of required thermal capacity $P_G$

#### Data required:

- Type: B3SH • Size: 09
- Nominal ratio:  $i_N = 56$
- Ambient temperature:  $t = 30\text{ °C}$
- Input speed:  $n_1 = 1500\text{ min}^{-1}$
- Gear unit with dip lubrication

#### For the calculation below the following has been assumed:

- Operating cycle: 100 %
- Installation in a large hall (wind velocity  $\geq 1.4\text{ m/s}$ ), altitude up to 1000 m
- Gear unit with mineral oil ISO-VG460

### 3. Détermination de la capacité thermique nécessaire $P_G$

#### Données nécessaires:

- Type: B3SH • Taille: 09
- Rapport nominal:  $i_N = 56$
- Température ambiante:  $t = 30\text{ °C}$
- Vitesse d'entrée:  $n_1 = 1500\text{ min}^{-1}$
- Réducteurs avec lubrification par barbotage

#### Les hypothèses suivantes sont prises en considération pour le calcul:

- Durée d'utilisation: 100 %
- Implantation dans un grand hall (Vitesse du vent  $\geq 1,4\text{ m/s}$ ) Altitude jusqu'à 1000 m
- Réducteurs avec huile minérale ISO-VG460

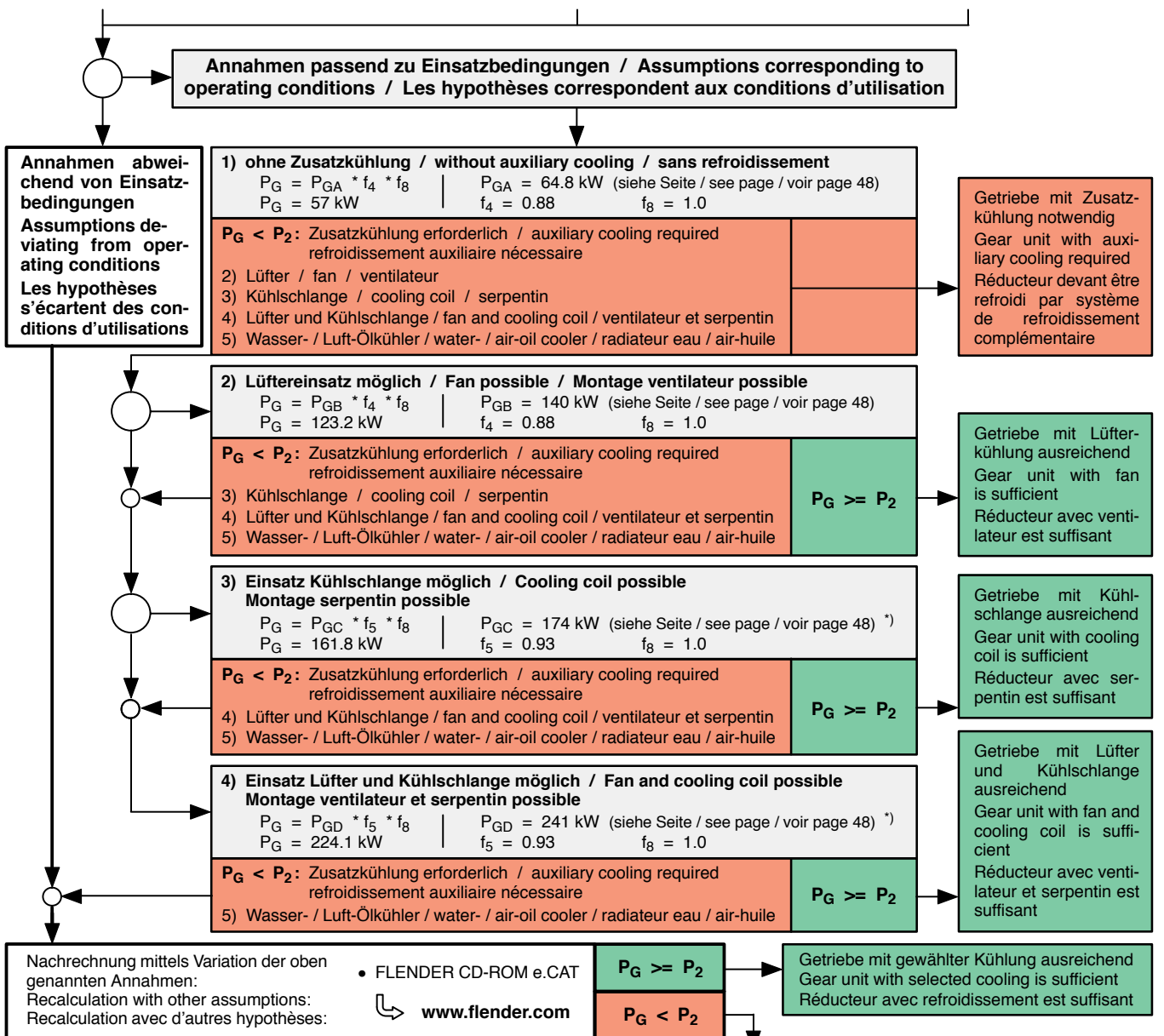

Das gewählte Getriebe B3SH 09 mit  $i_N = 56$  ist mit einer geeigneten Zusatzkühlung auszurüsten. Je nach Einsatzbedingungen beim Kunden ist mindestens ein Lüfter oder eine Kühlschlange vorzusehen.

For the selected gear unit B3SH 09 with  $i_N = 56$  suitable auxiliary cooling is to be provided. Depending on the operating conditions at the customer's, at least a fan or a cooling coil is to be provided.

Le réducteur choisi B3SH 09 avec  $i_N = 56$  doit être équipé d'un refroidissement additionnel approprié. Selon les conditions d'installation le client doit prévoir au minimum un ventilateur ou un serpentin.

Tabelle 1 Arbeitsmaschinenfaktor $f_1$ / Table 1 Factor for driven machine $f_1$ / Tableau 1 Facteur des machines entraînées $f_1$											
Arbeitsmaschinen Driven machines / Machines entraînée			1) ≤ 0.5   > 0.5-10   > 10			Arbeitsmaschinen Driven machines / Machines entraînée			1) ≤ 0.5   > 0.5-10   > 10		
<b>Abwasser</b>	<b>Waste water treatment</b>	<b>Eaux usées</b>				<b>Förderanlagen</b>	<b>Conveyors</b>	<b>Transporteurs-convoyeurs</b>			
Eindicker (Zentralantrieb)	Thickeners (central drive)	Epaisseur (entraînement central)	–	–	1.2	Becherwerke	Bucket conveyors	Convoyeurs à godets	–	1.4	1.5
Filterpressen	Filter presses	Filtres-presses	1.0	1.3	1.5	Förderhaspel	Hauling winches	Treulis de puits	1.4	1.6	1.6
Flockungsrührer	Flocculation apparatus	Agitateurs	0.8	1.0	1.3	Fördermaschinen	Hoists	Machines d'extraction	–	1.5	1.8
Kreisellüfter	Aerators	Ventilateurs circulaires	–	1.8	2.0	Gurtbandförderer ≤ 150 kW	Belt conveyors ≤ 150 kW	Convoyeurs à bandes ≤ 150 kW	1.0	1.2	1.3
Rechenanlagen	Raking equipment	Râteaux	1.0	1.2	1.3	Gurtbandförderer ≥ 150 kW	Belt conveyors ≥ 150 kW	Convoyeurs à bandes ≥ 150 kW	1.1	1.3	1.4
Rund- und Längsräumer	Combined longitudinal and rotary rakes	Déblayeurs circulaires et longitudinaux	1.0	1.3	1.5	Lastaufzüge *	Goods lifts *	Monte-charges *	–	1.2	1.5
Voreindicker	Pre-thickeners	Epaisseur primaires	–	1.1	1.3	Personenaufzüge *	Passenger lifts *	Ascenseurs *	–	1.5	1.8
Wasserschneckenpumpen	Screw pumps	Pompes à vis hydrauliques	–	1.3	1.5	Plattenbänder	Apron conveyors	Transporteurs à palettes	–	1.2	1.5
Wasserturbinen	Water turbines	Turbines hydrauliques	–	–	2.0	Rolltreppen	Escalators	Éscaliers roulants	1.0	1.2	1.4
<b>Pumpen</b>	<b>Pumps</b>	<b>Pompes</b>				Schienerfahrzeuge	Rail travelling gears	Véhicules sur rails	–	1.5	–
Kreiselpumpen	Centrifugal pumps	Pompes centrifuges	1.0	1.2	1.3	<b>Frequenzumformer</b>	<b>Frequency converters</b>	<b>Convertisseurs de fréquence</b>	–	1.8	2.0
Verdrängerpumpen	Positive-displacement pumps	Pompes volumétriques	1.3	1.4	1.8	<b>Kolbenverdichter</b>	<b>Reciprocating compressors</b>	<b>Compresseurs à pistons</b>	–	1.8	1.9
1 Kolben	1 piston	1 piston	1.2	1.4	1.5	<b>Krananlagen **</b>	<b>Cranes **</b>	<b>Engins de levage **</b>			
> 1 Kolben	> 1 piston	> piston				Drehwerke *	Slewing gears *	Mécanismes de rotation *	1.0	1.4	1.8
<b>Bagger</b>	<b>Dredgers</b>	<b>Excavateurs</b>				Einzieherwerke	Luffing gears	Mécanismes de relevage	1.0	1.1	1.4
Eimerketten	Bucket conveyors	Excavateurs à godets	–	1.6	1.6	Fahrwerke	Travelling gears	Mécanismes de translation	1.1	1.6	2.0
Kippwerke	Dumping devices	Bennes basculantes	–	1.3	1.5	Hubwerke	Hoisting gears	Mécanismes de levage	1.0	1.1	1.4
Raupenfahrzeuge	Caterpillar travelling gears	Mécanismes de translation sur chenilles	1.2	1.6	1.8	Wippwerke	Derricking jib cranes	Mécanismes à volée variable	1.0	1.2	1.6
<b>Schaeffler</b>	<b>Bucket wheel excavators</b>	<b>Roues-pelles</b>				<b>Kühltürme</b>	<b>Cooling towers</b>	<b>Tours de réfrigération</b>			
als Aufnehmer für Urmaterial	as pick-up for primitive material	pour pick-up pour matières de base	–	1.7	1.7	Kühlturmflüster	Cooling tower fans	Ventilateurs de tour de réfrigération	–	–	2.0
Schneidköpfe	Cutter heads	Têtes de forage	–	2.2	2.2	Gebläse (axial und radial)	Blowers (axial and radial)	Soufflante (axiale et radiale)	–	1.4	1.5
Schwenkwerke *	Slewing gears *	Commandes de pivotement *	–	1.4	1.8	<b>Nahrungsmittelindustrie</b>	<b>Food industry</b>	<b>Industrie alimentaire</b>			
<b>Blechbiegemaschinen *</b>	<b>Plate bending machines *</b>	<b>Pliques de tôle *</b>	–	1.0	1.0	<b>Rohrzuckerherstellung</b>	<b>Cane sugar production</b>	<b>Fabrication de sucre de canne</b>			
<b>Chemische Industrie</b>	<b>Chemical industry</b>	<b>Industrie chimique</b>				Zuckerrohr-Messer *	Cane knives *	Coupe cannes à sucre *	–	–	1.7
Extruder	Extruders	Extrudeuses	–	–	1.6	Zuckerrohr-Mühle	Cane mills	Broyeurs de cannes à sucre	–	–	1.7
Gummikneteter	Dough mills	Pétrisseurs de caoutchouc	–	1.8	1.8	<b>Rübenzuckerherstellung</b>	<b>Beet sugar production</b>	<b>Fabrication de sucre de betteraves</b>			
Gummikalender	Rubber calendars	Calandres à caoutchouc	–	1.5	1.5	Schnitzelmaische	Beet cassettes macerators,	Malaxeurs de cossette	–	–	1.2
Kühltrommeln	Cooling drums	Tambours de refroidissement	–	1.3	1.4	Extraktionsanlage, Kühlmaschine, Kochapparat,	Extraction plants, Mechanical refrigerators, Juice boilers,	Installations d'extraction, Refroidisseurs, Appareil à cuire	–	–	1.4
<b>Mischer für gleichmäßiges Gut</b>	<b>Mixers for uniform media</b>	<b>Malaxeurs pour matières homogènes</b>	1.0	1.3	1.4	Rübenwäsche, Schneidmaschine	Sugar beet washing machines, Sugar beet cutters	Laveurs pour betteraves, Coupeuses de betteraves	–	–	1.5
ungleichmäßiges Gut	non-uniform media	matières non homogènes	1.4	1.6	1.7	<b>Papiermaschinen</b>	<b>Paper machines</b>	<b>Machines à papier</b>			
<b>Rührwerke für Rührgut mit gleichmäßiger Dichte</b>	<b>Agitators for media with uniform density</b>	<b>Agitateurs pour matières avec densité homogène</b>	1.0	1.3	1.5	alle Arten ***	of all kind ***	en tout genre ***	–	1.8	2.0
ungleichmäßiger Dichte	non-uniform density	densité non homogène	1.2	1.4	1.6	Pulperantriebe (auf Anfrage)	Pulper drives (on request)	Pulper machines (sur demande)			
ungleichmäßige Begasung	non-uniform gas absorption	charge non homogène	1.4	1.6	1.8	<b>Rotierende Verdichter</b>	<b>Centrifugal compressors</b>	<b>Compresseurs rotatifs</b>	–	1.4	1.5
Toaster	Toasters	Toasters	1.0	1.3	1.5	<b>Seilbahnen</b>	<b>Cableways</b>	<b>Téléphériques</b>			
Zentrifugen	Centrifuges	Centrifugeuses	1.0	1.2	1.3	Materialbahnen	Material ropeways	Pour le transport du matériel	–	1.3	1.4
<b>Eisenhüttenwesen</b>	<b>Metal working mills</b>	<b>Laminoirs</b>				Pendelbahnen	To-and-fro system aerial ropeways	Navettes	–	1.6	1.8
Blechwender	Plate tilters	Retourneurs de tôles	1.0	1.0	1.2	Schleplifte	T-bar lifts	Remonte-pentes	–	1.3	1.4
Blockdrücker	Ingot pushers	Pousseurs de brames	1.0	1.2	1.2	Umlaufbahnen	Continuous ropeways	Télécabines	–	1.4	1.6
Haspeln	Winding machines	Bobineuses	–	1.6	1.6	<b>Zementindustrie</b>	<b>Cement industry</b>	<b>Industrie du ciment</b>			
Kühlbettschieber	Cooling bed transfer frames	Coulisseaux du refroidisseur	–	1.5	1.5	Betonmischer	Concrete mixers	Mélangeurs à béton	–	1.5	1.5
Rollenrichtmaschinen	Roller straighteners	Dresseuses à rouleaux	–	1.6	1.6	Brecher *	Breakers *	Concasseurs *	–	1.2	1.4
<b>Rollgänge</b>	<b>Roller tables</b>	<b>Lignes de rouleaux</b>				Drehöfen	Rotary kilns	Fours rotatifs	–	–	2.0
Durchlauf	continuous	continues	–	1.5	1.5	Rohrmühle	Tube mills	Tubes broyeur	–	–	2.0
Stoßartig	intermittent	intermittentes	–	2.0	2.0	Sichter	Separators	Séparateurs à air	–	1.6	1.6
Rohr-revers.	Reversing tube mills	Laminoirs réversibles à tubes	–	1.8	1.8	Walzenmühlen	Roll crushers	Broyeurs à cylindres	–	–	2.0
<b>Scheren</b>	<b>Shears</b>	<b>Cisailles</b>				<b>Laminieren</b>	<b>Bloomings</b>	<b>réversibles</b>			
Kurbelschnitt *	crank type *	coupe continue *	–	1.5	1.5	Slabbing	Slabbing	réversibles			
Kurbelschnitt *	crank type *	coupe à manivelle *	1.0	1.0	1.0	Trains réversibles à fil	Trains réver. à tôles fines	Trains réversibles à fil	–	1.8	1.8
Stranggußtreiber *	Continuous casting drivers *	Entraîneurs de coulée continue *	–	1.4	1.4	Trains réver. à tôles fortes	Trains réver. à tôles fortes	Trains réver. à tôles fortes	–	2.0	2.0
<b>Walzen</b>	<b>Rolls</b>	<b>Laminoirs</b>				Serrage des cylindres	Serrage des cylindres	Serrage des cylindres	0.9	1.0	–
Blech-revers.	Reversing blooming mills	Bloomings réversibles	–	2.5	2.5						
Brammen-revers.	Reversing slabbing mills	Slabbing réversibles	–	2.5	2.5						
Draht-revers.	Reversing wire mills	Trains réversibles à fil	–	1.8	1.8						
Feinblech-revers.	Reversing sheet mills	Trains réver. à tôles fines	–	2.0	2.0						
Grobblech-revers.	Reversing plate mills	Trains réver. à tôles fortes	–	1.8	1.8						
Walzenanstellungen	Roll adjustment drives	Serrage des cylindres	0.9	1.0	–						

## Betriebsfaktoren

## Service Factors

## Facteurs de service

Auslegung für Arbeitsmaschinenleistung  $P_2$

- \*) Auslegung entsprechend dem Maximalmoment
  - \*\*) Genaue Einstufung der Belastung kann z.B. nach FEM 1001 erfolgen
  - \*\*\*) Thermische Überprüfung generell erforderlich
- Die aufgeführten Faktoren sind Erfahrungswerte. Ihre Anwendung setzt für die genannten Maschinen oder Anlagen hierfür allgemein bekannte Konstruktions- und Belastungsbedingungen voraus. Bei Abweichung von Normalbedingungen ist Rückfrage erforderlich. Für nicht aufgeführte Arbeitsmaschinen bitten wir um Rückfrage.

1) Tatsächliche tägliche Laufzeit unter Last in Stunden

Design for power rating of driven machine  $P_2$

- \*) Designed power corresponding to max. torque
- \*\*) Load can be exactly classified, for instance, according to FEM 1001
- \*\*\*) A check for thermal capacity is absolutely essential

The listed factors are empirical values. Prerequisite for their application is that the machinery and equipment mentioned correspond to generally accepted design- and load specifications. In case of deviations from standard conditions, please refer to us. For driven machines which are not listed in this table, please refer to us.

1) Effective daily operating period under load in hours

Explication pour la puissance absorbée machine  $P_2$

- \*) Puissance calculée correspondant au couple max.
- \*\*) Un classement précis de la charge peut être effectué par exemple selon FEM 1001
- \*\*\*) Vérification thermique nécessaire

Les facteurs mentionnés sont des valeurs issues de notre expérience. Si les conditions de fonctionnement ne sont pas respectées ou si l'utilisation de machines de travail non citées est prévue, nous vous prions de bien vouloir nous consulter. Nous consulter au sujet des machines de travail ne figurant pas dans cette liste.

1) Durée de fonctionnement journalier effective sous charge en heure

Tabelle 2	Antriebsmaschinenfaktor $f_2$	
Elektromotoren, Hydromotoren, Turbinen	1.0	
Kolbenmaschinen 4 - 6 Zylinder, Ungleichförmigkeitsgrad 1 : 100 bis 1 : 200	1.25	
Kolbenmaschinen 1 - 3 Zylinder Ungleichförmigkeitsgrad 1 : 100	1.5	

Table 2	Factor for prime mover $f_2$	
Electric motors, hydraulic motors, turbines	1.0	
Piston engines 4 - 6 cylinders, cyclic variation 1 : 100 to 1 : 200	1.25	
Piston engines 1 - 3 cylinders, cyclic variation up to 1 : 100	1.5	

Tableau 2	Facteur des machines motrices $f_2$	
Moteurs électriques, Moteurs hydrauliques, Turbinen	1.0	
Moteurs à pistons 4 - 6 cylindres Coefficient d'irrégularité 1 : 100 à 1 : 200	1.25	
Moteurs à pistons 1 - 3 cylindres Coefficient d'irrégularité jusqu'à 1 : 100	1.5	

Tabelle 3	Spitzenmomentfaktor $f_3$	Belastungsspitzen pro Stunde			
		1 - 5	6 - 30	31 - 100	> 100
gleichbleibende Lastrichtung	0.5	0.65	0.7	0.85	
wechselnde Lastrichtung	0.7	0.95	1.10	1.25	

Table 3	Peak torque factor $f_3$	Load peaks per hour			
		1 - 5	6 - 30	31 - 100	> 100
Steady direction of load	0.5	0.65	0.7	0.85	
Alternating direction of load	0.7	0.95	1.10	1.25	

Tableau 3	Facteur de point max. $f_3$	Pointes de charge par heure			
		1 - 5	6 - 30	31 - 100	> 100
Direction permanente de la charge	0.5	0.65	0.7	0.85	
Direction intermittente de la charge	0.7	0.95	1.10	1.25	

Tabelle 4	Wärmefaktor	(Getriebe ohne Zusatzkühlung oder mit Lüfterkühlung)									
Table 4	Thermal factor	(Gear units without auxiliary cooling or with fan)									
Tableau 4	Facteur thermique	(Réducteurs sans refroidissement supplémentaire ou avec ventilateur)									
		$f_4$									
Umgebungstemperatur / Ambient temperature / Température ambiante	10 °C	15 °C	20 °C	25 °C	30 °C	35 °C	40 °C	45 °C	50 °C		
$f_4$	1.11	1.06	1.00	0.94	0.88	0.82	0.75	0.69	0.63		

Tabelle 5	Wärmefaktor	(Mit Kühlung durch Kühlschlange oder mit Kühlung durch Lüfter und Kühlschlange)									
Table 5	Thermal factor	(For cooling with cooling coil, or with fan and cooling coil)									
Tableau 5	Facteur thermique	(Avec refroidissement par serpentin ou ventilateur et serpentin)									
		$f_5$									
Umgebungstemperatur / Ambient temperature / Température ambiante	10 °C	15 °C	20 °C	25 °C	30 °C	35 °C	40 °C	45 °C	50 °C		
$f_5$	1.05	1.03	1.00	0.97	0.93	0.90	0.87	0.84	0.81		

Tabelle 8	Ölversorgungsfaktor bei Vertikalgetrieben. Bei Horizontalgetrieben $f_8 = 1.0$ , und $f_8 = 1.05$ bei Druckschmierung	$f_8$
Table 8	Oil supply factor for vertical gear units. For horizontal gear units $f_8 = 1.0$ , and in case of forced lubrication $f_8 = 1.05$	
Tableau 8	Facteur de type de lubrification pour les réducteurs verticaux. Pour les réducteurs horizontaux $f_8 = 1.0$ , respectivement $f_8 = 1.05$ en cas de lubrification sous pression	

Getriebebauart Gear unit type Réducteur type	Ölversorgung Oil supply Lubrification	Größen / Sizes / Tailles 4 - 12				Größen / Sizes / Tailles 13 - 18			
		ohne without / sans Zusatzkühlung Auxiliary cooling Réfrigérant auxiliaire	mit / with avec Lüfter Fan Ventilateur	mit / with avec Kühlschlange Cooling coil Serpentin de refroidissement	mit / with / avec Lüfter und Kühlschlange Fan and cooling coil Ventilateur et serpentin de refroidissement	ohne without / sans Zusatzkühlung Auxiliary cooling Réfrigérant auxiliaire	mit / with avec Lüfter Fan Ventilateur	mit / with avec Kühlschlange Cooling coil Serpentin de refroidissement	mit / with / avec Lüfter und Kühlschlange Fan and cooling coil Ventilateur et serpentin de refroidissement
H2.V H3.V H4.V	Tauchschröpfung Dip lubrication Lubrification par barbotage	0.95	+	0.95	+	+	+	+	+
	Druckschröpfung Forced lubrication Graissage sous pression	1.15	+	1.05	+	1.15	+	1.05	+
B2.V B3.V B4.V	Tauchschröpfung Dip lubrication Lubrification par barbotage	0.95	0.95	0.95	0.95	+	+	+	+
	Druckschröpfung Forced lubrication Graissage sous pression	1.15	1.10	1.10	1.10	1.15	1.10	1.10	1.10

+) Auf Anfrage

+) On request

+) Sur demande

# Zahnradgetriebe

Nennleistungen  
Bauart H1..  
Größen 3 - 26

# Gear Units

Nominal Power Ratings  
Type H1..  
Sizes 3 - 26

# Réducteurs à engrenages

Puissances nominales  
Type H1..  
Tailles 3 - 26

Nennleistungen P <sub>2N</sub> (kW) / Nominal power ratings P <sub>2N</sub> (kW) / Puissances nominales P <sub>2N</sub> (kW)																										
i <sub>N</sub>	n <sub>1</sub>	n <sub>2</sub>	Getriebegrößen / Gear unit sizes / Tailles réducteurs																							
			3	4	5	6	7	8	9	10	11	12	13	14	15	16	17	18	19	20	21	22	23	24	25	26
1.25	1800	1440	437		1206		2291 *		3724 *																	
	1500	1200	364		1005		1909		3103																	
	1200	960	291		804		1527		2482																	
	1000	800	242		670		1273		2069																	
1.4	1800	1286	417		1104		2141 *		3447 *																	
	1500	1071	347		919		1783		2870																	
	1200	857	278		735		1426		2297																	
	1000	714	231		613		1188		1913																	
1.6	1800	1125	388		1013		1920 *		3192 *																	
	1500	938	324		844		1600		2661		4518															
	1200	750	259		675		1280		2128		3612															
	1000	625	215		562		1066		1773		3010		4410													
1.8	1800	1000	282		921		1821 *		2931 *		4984 *															
	1500	833	235		767		1517		2442		4151															
	1200	667	188		614		1215		1955		3324		4951 *													
	1000	556	157		512		1013		1630		2771		4127													
2	1800	900	263		885		1677 *		2704 *		4627 *															
	1500	750	219		738		1397		2253		3856															
	1200	600	175		590		1118		1803		3084		4580 *													
	1000	500	146		492		931		1502		2570		3816													
2.24	1800	804	235		808		1498 *		2416 *		4259 *															
	1500	670	196		673		1248		2013		3549															
	1200	536	157		538		999		1610		2839		4220 *													
	1000	446	130		448		831		1340		2363		3511													
2.5	1800	720	218		723		1341 *		2163 *		3814 *															
	1500	600	182		603		1118		1803		3179		4837 *													
	1200	480	145		482		894		1442		2543		3870 *													
	1000	400	121		402		745		1202		2119		3225		4900											
2.8	1800	643	208		646		1151 *		1831 *		3406 *															
	1500	536	173		538		959		1526		2839		4321 *													
	1200	429	139		431		768		1221		2273		3458 *													
	1000	357	115		358		639		1016		1891		2878		4485											
3.15	1800	571	185		573		1040		1680		2875 *		4370 *													
	1500	476	154		478		867		1400		2397		3643													
	1200	381	123		382		694		1121		1918		2916		4947 *											
	1000	317	102		318		577		932		1596		2426		4116											
3.55	1800	507	169		504		944		1518		2665 *		3949 *													
	1500	423	141		420		788		1266		2223		3295													
	1200	338	113		336		629		1012		1776		2633		4459 *											
	1000	282	94		280		525		844		1482		2196		3720											
4	1800	450	150		452		838		1352		2384 *		3567 *													
	1500	375	125		376		698		1126		1986		2972													
	1200	300	100		301		559		901		1589		2378		4083 *											
	1000	250	83		251		465		751		1324		1981		3403		4528									
4.5	1800	400	104		322		661		1030		1926		2580 *		4565 *											
	1500	333	87		268		550		857		1603		2147		3800											
	1200	267	69		215		441		687		1286		1722		3047		4081 *									
	1000	222	58		178		367		571		1069		1431		2533		3393									
5	1800	360	90		271		520		885		1458		2197 *		3581 *		4674 *									
	1500	300	75		226		433		738		1215		1831		2984		3895 *									
	1200	240	60		180		346		590		972		1465		2387		3116 *		4372 *							
	1000	200	50		150		289		492		810		1220		1989		2596		3643							
5.6	1800	321	77		231		440		675		1226		1862 *		3038 *		3966 *									
	1500	268	64		193		367		564		1024		1554		2536		3311 *		4209 *							
	1200	214	51		154		293		450		817		1241		2025		2644		3361 *							
	1000	179	43		129		245		376		684		1038		1694		2211		2811							

Druckschmierung bei Horizontalgetrieben erforderlich    
  Forced lubrication required on horizontal gear units    
  La lubrification sous pression est nécessaire en position horizontale pour ces réducteurs  
 \* Getriebe nur auf Anfrage    
  \* Gear units only on request    
  \* Réducteur à engrenages seulement sur demande

# Zahnradgetriebe

Nenn-Abtriebsdrehmomente  
Bauart H1..  
Größen 3 - 26

# Gear Units

Nominal Output Torques  
Type H1..  
Sizes 3 - 26

# Réducteurs à engrenages

Couples nominaux de sortie  
Type H1..  
Tailles 3 - 26

Nenn-Abtriebsdrehmomente $T_{2N}$ (kNm) Nominal output torques $T_{2N}$ (kNm) / Couples nominaux de sortie $T_{2N}$ (kNm)																									
$i_N$	Getriebegrößen / Gear unit sizes / Tailles réducteurs																								
	3	4	5	6	7	8	9	10	11	12	13	14	15	16	17	18	19	20	21	22	23	24	25	26	
1.25	2.9		8		15.2		24.7																		
1.4	3.1		8.2		15.9		25.6																		
1.6	3.3		8.6		16.3		27.1		46		67.4														
1.8	2.7		8.8		17.4		28		47.6		70.9														
2	2.8		9.4		17.8		28.7		49.1		72.9		129												
2.24	2.8		9.6		17.8		28.7		50.6		75.2		130												
2.5	2.9		9.6		17.8		28.7		50.6		77		117												
2.8	3.1		9.6		17.1		27.2		50.6		77		120		171										
3.15	3.1		9.6		17.4		28.1		48.1		73.1		124		173										
3.55	3.2		9.5		17.8		28.6		50.2		74.4		126		173										
4	3.2		9.6		17.8		28.7		50.6		75.7		130		173		245								
4.5	2.5		7.7		15.8		24.6		46		61.6		109		146		216								
5	2.4		7.2		13.8		23.5		38.7		58.3		95		124		174								
5.6	2.3		6.9		13.1		20.1		36.5		55.4		90.4		118		150								
6.3		6.3	10.7		20.3		33.7		59.3		86		143		195		292								
7.1		6.5	11.2		20.3		33.7		59.3		86		143	160	195	230	292	335	410						
8		6.7	11.2	13.5	20.3	25.6	33.7	42.2	59.3	73.8	86	107	143	160	195	230	292	335	410	458					
9		6.7	11.2	14.4	20.3	25.6	33.7	42.2	59.3	73.8	86	107	143	160	195	230	292	335	410	458	540				
10		6.3	10.5	14.4	20.3	25.6	33.7	42.2	59.3	73.8	86	107	143	160	195	230	292	335	410	458	540	620			
11.2		6.3	10.6	14.4	20.3	25.6	33.7	42.2	59.3	73.8	86	107	143	160	195	230	292	335	410	458	540	620	780		
12.5		6.7	11.2	13.5	20.2	25.6	33.7	42.2	59.3	73.8	86	107	143	160	195	230	292	335	410	458	540	620	780	880	
14		6.7	11.2	13.5	20.3	25.6	33.7	42.2	59.3	73.8	86	107	143	160	195	230	292	335	410	458	540	620	780	880	
16		6.7	11.2	14.4	20.3	25.5	33.7	42.2	59.3	73.8	86	107	143	160	195	230	292	335	410	458	540	620	780	880	
18		6.3	10.5	14.4	19	25.6	33.7	42.2	59.3	73.8	86	107	143	160	195	230	292	335	410	458	540	620	780	880	
20		6.6	11.2	14.4	19	25.6	33.7	42.2	59.3	73.8	86	107	143	160	195	230	292	335	410	458	540	620	780	880	
22.4		6.3	10.9	13.5	19.8	24	33.1	42.2	58.3	73.8	88	107	153	160	200	230	300	335	420	458	560	620	800	880	
25			11.6	14.3	21.7	24	35.7	42.2	63.5	73.8	88	107	153	173	200	240	300	345	420	470	560	640	800	900	
28			11.6	13.9	21.7	25	35.7	41.6	63.5	72.5	88	109	153	173	200	240	300	345	420	470	560	640	800	900	
31.5			11.6	15.5	21.7	27.2	35.7	43.8	63.5	77.2	88	109	153	173	200	240	300	345	420	470	560	640	800	900	
35.5			11.6	15.5	21.7	27.2	35.7	43.8	63.5	77.2	88	109	153	173	200	240	300	345	420	470	560	640	800	900	
40			11.6	15.5	21.7	27.2	35.7	43.8	63.5	77.2	88	109	153	173	200	240	300	345	420	470	560	640	800	900	
45			11.6	15.5	21.7	27.2	35.7	43.8	63.5	77.2	88	109	153	173	200	240	300	345	420	470	560	640	800	900	
50			11.6	15.5	21.7	27.2	35.7	43.8	63.5	77.2	88	109	153	173	200	240	300	345	420	470	560	640	800	900	
56			11.6	15.5	21.7	27.2	35.7	43.8	63.5	77.2	88	109	153	173	200	240	300	345	420	470	560	640	800	900	
63			11.6	15.5	21.7	27.2	35.7	43.8	63.5	77.2	88	109	153	173	200	240	300	345	420	470	560	640	800	900	
71			11.6	15.5	21.7	27.2	35.7	43.8	63.5	77.2	88	109	153	173	200	240	300	345	420	470	560	640	800	900	
80			11.6	15.5	21.7	27.2	35.7	43.8	63.5	77.2	88	109	153	173	200	240	300	345	420	470	560	640	800	900	
90			11.6	15.5	20	27.2	34.5	43.8	63.5	77.2	88	109	153	173	200	240	290	345	410	470	560	640	800	900	
100				14.5	21.7	27.2	35.7	43.8	61.6	77.2	90.7	109	153	173	200	226	300	335	420	465	560	640	800	900	
112				15	21.7	25.2	35.7	42.8	61.6	77.2	90.7	109	153	173	200	240	300	345	420	470	560	640	800	900	
125					21.7	27.2	35.7	44.2	61.6	78	90.7	113	153	173	200	240	300	345	420	470	560	640	800	900	
140					21.7	27.2	35.7	44.2	61.6	78	90.7	113	153	173	200	240	300	345	420	470	560	640	800	900	
160					21.7	27.2	35.7	44.2	61.6	78	90.7	113	153	173	200	240	300	345	420	470	560	640	800	900	
180					21.7	27.2	35.7	44.2	61.6	78	90.7	113	153	173	200	240	300	345	420	470	560	640	800	900	
200					21.7	27.2	35.7	44.2	61.6	78	90.7	113	153	173	200	240	300	345	420	470	560	640	800	900	
224					21.7	27.2	35.7	44.2	61.6	78	90.7	113	153	173	200	240	300	345	420	470	560	640	800	900	
250					21.7	27.2	35.7	44.2	61.6	78	90.7	113	153	173	200	240	300	345	420	470	560	640	800	900	
280					21.7	27.2	35.7	44.2	61.6	78	90.7	113	153	173	200	240	300	345	420	470	560	640	800	900	
315					21.7	27.2	35.7	44.2	61.6	78	90.7	113	153	173	200	240	300	345	420	470	560	640	800	900	
355					19.6	27.2	35.7	44.2	61.6	78	90.7	113	140	173	192	240	290	345	410	470	560	640	800	900	
400						27.2		44.2		78		113		158		223		335		465		640		900	
450						25.3		42.8		78		113													

# Zahnradgetriebe

Wärmegrenzleistungen

Bauart H1..

Größen 3 - 26

$n_1 = 1000 \text{ min}^{-1}$

# Gear Units

Thermal Capacities

Type H1..

Sizes 3 - 26

$n_1 = 1000 \text{ min}^{-1}$

# Réducteurs à engrenages

Capacités thermiques

Type H1..

Tailles 3 - 26

$n_1 = 1000 \text{ min}^{-1}$

Wärmegrenzleistungen  $P_G$  (kW) / Thermal capacities  $P_G$  (kW) / Capacités thermiques  $P_G$  (kW)

$i_N$		Getriebegrößen / Gear unit sizes / Tailles réducteurs																							
		3	4	5	6	7	8	9	10	11	12	13	14	15	16	17	18	19	20	21	22	23	24	25	26
1.25	$P_{GA}$	63.2	*	*	*	*	*	*	*	*	*	*	*	*	*	*	*	*	*	*	*	*	*	*	*
	$P_{GB}$	187		402		517		536																	
	$P_{GC}$	271		639		911		1288																	
	$P_{GD}$	377		934		1322		1783																	
1.4	$P_{GA}$	65.4	*	*	*	*	*	*	*	*	*	*	*	*	*	*	*	*	*	*	*	*	*	*	*
	$P_{GB}$	186		409		534		578																	
	$P_{GC}$	264		629		892		1277																	
	$P_{GD}$	366		916		1298		1760																	
1.6	$P_{GA}$	68.6	*	*	*	*	*	*	*	*	*	*	*	*	*	*	*	*	*	*	*	*	*	*	*
	$P_{GB}$	183		412		540		630		729		510													
	$P_{GC}$	248		595		833		1230		2057		2459													
	$P_{GD}$	347		870		1214		1706		2838		3313													
1.8	$P_{GA}$	79.9	*	*	*	*	*	*	*	*	*	*	*	*	*	*	*	*	*	*	*	*	*	*	*
	$P_{GB}$	205		410		561		655		821		674													
	$P_{GC}$	269		561		819		1187		2025		2417													
	$P_{GD}$	376		827		1196		1650		2802		3264													
2	$P_{GA}$	78.5		104		*		*		*		*		*		*		*		*		*		*	
	$P_{GB}$	197		397		549		651		852		757		*		*		*		*		*		*	
	$P_{GC}$	256		531		778		1130		1955		2368		2073		*		*		*		*		*	
	$P_{GD}$	358		779		1135		1573		2700		3190		3116		*		*		*		*		*	
2.24	$P_{GA}$	78		109		*		*		*		*		*		*		*		*		*		*	
	$P_{GB}$	189		382		520		645		887		851		523		*		*		*		*		*	
	$P_{GC}$	241		496		704		1063		1864		2290		2048		*		*		*		*		*	
	$P_{GD}$	338		733		1029		1485		2588		3104		3073		*		*		*		*		*	
2.5	$P_{GA}$	72.8		108		*		*		*		*		*		*		*		*		*		*	
	$P_{GB}$	175		362		494		621		884		888		621		*		*		*		*		*	
	$P_{GC}$	216		459		649		986		1753		2174		2016		*		*		*		*		*	
	$P_{GD}$	304		679		950		1381		2437		2955		2996		*		*		*		*		*	
2.8	$P_{GA}$	69.6		105		133		*		*		*		*		*		*		*		*		*	
	$P_{GB}$	164		340		511		649		865		902		707		500		*		*		*		*	
	$P_{GC}$	199		419		655		994		1625		2034		1957		2203		*		*		*		*	
	$P_{GD}$	281		620		959		1390		2265		2770		2892		3223		*		*		*		*	
3.15	$P_{GA}$	73		127		189		217		*		*		*		*		*		*		*		*	
	$P_{GB}$	161		348		601		731		1019		1128		1146		1040		*		*		*		*	
	$P_{GC}$	193		416		769		1091		1682		2075		2179		2517		*		*		*		*	
	$P_{GD}$	270		612		1140		1548		2349		2844		3174		3624		*		*		*		*	
3.55	$P_{GA}$	67.6		127		178		209		*		*		*		*		*		*		*		*	
	$P_{GB}$	147		340		553		682		949		1078		1140		1096		*		*		*		*	
	$P_{GC}$	174		398		689		988		1519		1896		2027		2387		*		*		*		*	
	$P_{GD}$	244		585		1027		1407		2128		2603		2942		3412		*		*		*		*	
4	$P_{GA}$	61.9		118		167		189		235		*		*		*		*		*		*		*	
	$P_{GB}$	134		309		498		585		891		1024		1124		1132		1032		*		*		*	
	$P_{GC}$	155		353		604		820		1372		1715		1851		2212		*		*		*		*	
	$P_{GD}$	217		521		902		1175		1927		2364		2692		3158		*		*		*		*	
4.5	$P_{GA}$	69.7		129		183		238		267		304		*		*		*		*		*		*	
	$P_{GB}$	144		316		504		667		872		1107		1289		1307		1274		*		*		*	
	$P_{GC}$	165		354		599		908		1310		1783		1908		2227		*		*		*		*	
	$P_{GD}$	230		521		889		1294		1855		2474		2760		3170		*		*		*		*	
5	$P_{GA}$	63.9		125		184		228		290		340		*		*		*		*		*		*	
	$P_{GB}$	131		301		488		608		869		1087		1317		1541		1585		*		*		*	
	$P_{GC}$	147		333		564		801		1243		1686		1820		2424		*		*		*		*	
	$P_{GD}$	205		490		841		1145		1770		2348		2642		3447		*		*		*		*	
5.6	$P_{GA}$	57.2		111		166		220		277		311		*		*		*		*		*		*	
	$P_{GB}$	116		266		435		581		823		978		1195		1416		1665		*		*		*	
	$P_{GC}$	128		288		494		745		1164		1478		1608		2157		*		*		*		*	
	$P_{GD}$	179		425		739		1071		1663		2065		2338		3069		*		*		*		*	

\* Auf Anfrage  
 $P_{GA}$  (kW) Getriebe ohne Zusatzkühlung \*\*  
 $P_{GB}$  (kW) Getriebe mit Lüfterkühlung \*\*  
 $P_{GC}$  (kW) Getriebe mit eingebauter Kühlschlange \*\* (\*\*\*)  
 $P_{GD}$  (kW) Getriebe mit Lüfter und eingebauter Kühlschlange \*\* (\*\*\*)  
 \*\*) Werte gelten für:  
 Einschaltdauer: 100 %  
 Aufstellung in großer Halle  
 Höhenlage bis 1000 m  
 \*\*\*) Werte gelten für eine Kühlwassereintrittstemperatur von 20 °C ohne Begrenzung der Kühlwasseraustrittstemperatur.  
 Die Nachrechnung mit Begrenzung der Kühlwasseraustrittstemperatur ist auf Anfrage möglich.

\* On request  
 $P_{GA}$  (kW) Gear units without auxiliary cooling \*\*  
 $P_{GB}$  (kW) Gear units with fan \*\*  
 $P_{GC}$  (kW) Gear units with built-in cooling coil \*\* (\*\*\*)  
 $P_{GD}$  (kW) Gear units with fan and built-in cooling coil \*\* (\*\*\*)  
 \*\*) Values refer to:  
 Operating cycle: 100 %  
 Installation in a large hall  
 Altitude up to 1000 m  
 \*\*\*) Values refer to a cooling water inlet temperature of 20 °C with unlimited cooling water outlet temperature.  
 A recalculation with a limited cooling water outlet temperature is possible on request.

\* Sur demande  
 $P_{GA}$  (kW) Réducteurs sans refroidissement supplémentaire \*\*  
 $P_{GB}$  (kW) Réducteurs avec ventilateur \*\*  
 $P_{GC}$  (kW) Réducteurs avec serpentin intégré \*\* (\*\*\*)  
 $P_{GD}$  (kW) Réducteurs avec ventilateur et serpentin intégré \*\* (\*\*\*)  
 \*\*) Les valeurs sont valables pour:  
 Durée d'utilisation: 100 %  
 Implantation dans un grand hall  
 Altitude jusqu'à 1000 m  
 \*\*\*) Les données sont valables pour une température d'eau de refroidissement en entrée de 20 °C sans limitation de la température de l'eau en sortie.  
 Un calcul avec limitation de la température d'eau en sortie est possible sur demande.

# Zahnradgetriebe

Wärmegrenzleistungen

Bauart H1..

Größen 3 - 26

$n_1 = 1200 \text{ min}^{-1}$

# Gear Units

Thermal Capacities

Type H1..

Sizes 3 - 26

$n_1 = 1200 \text{ min}^{-1}$

# Réducteurs à engrenages

Capacités thermiques

Type H1..

Tailles 3 - 26

$n_1 = 1200 \text{ min}^{-1}$

Wärmegrenzleistungen P <sub>G</sub> (kW) / Thermal capacities P <sub>G</sub> (kW) / Capacités thermiques P <sub>G</sub> (kW)																									
i <sub>N</sub>		Getriebegrößen / Gear unit sizes / Tailles réducteurs																							
		3	4	5	6	7	8	9	10	11	12	13	14	15	16	17	18	19	20	21	22	23	24	25	26
1.25	P <sub>GA</sub>	*		*		*		*																	
	P <sub>GB</sub>	201		397		480		446																	
	P <sub>GC</sub>	296		666		923		1254																	
	P <sub>GD</sub>	432		1050		1468		1946																	
1.4	P <sub>GA</sub>	*		*		*		*																	
	P <sub>GB</sub>	201		410		507		501																	
	P <sub>GC</sub>	289		660		913		1260																	
	P <sub>GD</sub>	420		1033		1447		1932																	
1.6	P <sub>GA</sub>	57		*		*		*		*		*		*		*		*		*		*		*	
	P <sub>GB</sub>	200		424		533		584		528		*		*		*		*		*		*		*	
	P <sub>GC</sub>	273		634		869		1246		1924		2078		*		*		*		*		*		*	
	P <sub>GD</sub>	400		987		1365		1894		3045		3406		*		*		*		*		*		*	
1.8	P <sub>GA</sub>	69.1		*		*		*		*		*		*		*		*		*		*		*	
	P <sub>GB</sub>	225		429		570		633		670		*		*		*		*		*		*		*	
	P <sub>GC</sub>	298		604		866		1225		1958		2157		*		*		*		*		*		*	
	P <sub>GD</sub>	434		942		1352		1846		3049		3433		*		*		*		*		*		*	
2	P <sub>GA</sub>	68.7		*		*		*		*		*		*		*		*		*		*		*	
	P <sub>GB</sub>	218		418		562		638		718		*		*		*		*		*		*		*	
	P <sub>GC</sub>	284		573		826		1173		1911		2150		1659		*		*		*		*		*	
	P <sub>GD</sub>	413		889		1286		1765		2952		3380		3133		*		*		*		*		*	
2.24	P <sub>GA</sub>	69.9		*		*		*		*		*		*		*		*		*		*		*	
	P <sub>GB</sub>	210		408		541		647		792		625		*		*		*		*		*		*	
	P <sub>GC</sub>	268		539		754		1117		1860		2148		1734		*		*		*		*		*	
	P <sub>GD</sub>	391		839		1170		1675		2855		3335		3162		*		*		*		*		*	
2.5	P <sub>GA</sub>	66		*		*		*		*		*		*		*		*		*		*		*	
	P <sub>GB</sub>	195		389		518		631		810		691		*		*		*		*		*		*	
	P <sub>GC</sub>	241		500		699		1042		1768		2073		1752		*		*		*		*		*	
	P <sub>GD</sub>	352		778		1082		1561		2700		3196		3117		*		*		*		*		*	
2.8	P <sub>GA</sub>	63.7		*		*		*		*		*		*		*		*		*		*		*	
	P <sub>GB</sub>	183		366		540		667		812		738		*		*		*		*		*		*	
	P <sub>GC</sub>	222		458		708		1057		1656		1969		1745		*		*		*		*		*	
	P <sub>GD</sub>	325		712		1095		1576		2520		3016		3041		*		*		*		*		*	
3.15	P <sub>GA</sub>	70.1		113		159		*		*		*		*		*		*		*		*		*	
	P <sub>GB</sub>	181		385		658		789		1055		1109		1024		860		*		*		*		*	
	P <sub>GC</sub>	217		463		848		1193		1798		2159		2175		2445		*		*		*		*	
	P <sub>GD</sub>	314		707		1314		1777		2669		3194		3501		3951		*		*		*		*	
3.55	P <sub>GA</sub>	65		114		153		*		*		*		*		*		*		*		*		*	
	P <sub>GB</sub>	166		376		607		738		990		1072		1040		934		*		*		*		*	
	P <sub>GC</sub>	196		443		761		1083		1629		1983		2040		2342		*		*		*		*	
	P <sub>GD</sub>	284		676		1184		1616		2421		2930		3257		3736		*		*		*		*	
4	P <sub>GA</sub>	60		108		147		156		*		*		*		*		*		*		*		*	
	P <sub>GB</sub>	151		344		549		637		942		1040		1065		1018		873		*		*		*	
	P <sub>GC</sub>	174		394		670		903		1482		1813		1894		2213		*		*		*		*	
	P <sub>GD</sub>	252		603		1042		1352		2200		2673		3001		3488		*		*		*		*	
4.5	P <sub>GA</sub>	68.4		121		169		211		*		*		*		*		*		*		*		*	
	P <sub>GB</sub>	163		355		562		737		944		1168		1303		1283		1210		*		*		*	
	P <sub>GC</sub>	186		397		669		1009		1436		1925		2012		2315		*		*		*		*	
	P <sub>GD</sub>	268		604		1030		1495		2131		2823		3118		3558		*		*		*		*	
5	P <sub>GA</sub>	63.2		121		174		211		248		*		*		*		*		*		*		*	
	P <sub>GB</sub>	149		339		547		678		953		1171		1378		1581		1592		*		*		*	
	P <sub>GC</sub>	166		375		633		894		1374		1843		1955		2577		*		*		*		*	
	P <sub>GD</sub>	239		569		976		1326		2041		2694		3009		3907		*		*		*		*	
5.6	P <sub>GA</sub>	56.6		107		157		202		237		*		*		*		*		*		*		*	
	P <sub>GB</sub>	132		299		488		647		903		1054		1251		1453		1672		*		*		*	
	P <sub>GC</sub>	145		324		555		833		1287		1616		1728		2293		*		*		*		*	
	P <sub>GD</sub>	208		494		857		1240		1917		2369		2662		3478		*		*		*		*	

\* Auf Anfrage  
P<sub>GA</sub> (kW) Getriebe ohne Zusatzkühlung \*\*  
P<sub>GB</sub> (kW) Getriebe mit Lüfterkühlung \*\*  
P<sub>GC</sub> (kW) Getriebe mit eingebauter Kühlschlange \*\* \*\*\*  
P<sub>GD</sub> (kW) Getriebe mit Lüfter und eingebauter Kühlschlange \*\* \*\*\*

\*\* Werte gelten für:  
Einschaltdauer: 100 %  
Aufstellung in großer Halle  
Höhenlage bis 1000 m  
\*\*\* Werte gelten für eine Kühlwassereintrittstemperatur von 20 °C ohne Begrenzung der Kühlwasseraustrittstemperatur.  
Die Nachrechnung mit Begrenzung der Kühlwasseraustrittstemperatur ist auf Anfrage möglich.

\* On request  
P<sub>GA</sub> (kW) Gear units without auxiliary cooling \*\*  
P<sub>GB</sub> (kW) Gear units with fan \*\*  
P<sub>GC</sub> (kW) Gear units with built-in cooling coil \*\* \*\*\*  
P<sub>GD</sub> (kW) Gear units with fan and built-in cooling coil \*\* \*\*\*

\*\* Values refer to:  
Operating cycle: 100 %  
Installation in a large hall  
Altitude up to 1000 m  
\*\*\* Values refer to a cooling water inlet temperature of 20 °C with unlimited cooling water outlet temperature.  
A recalculation with a limited cooling water outlet temperature is possible on request.

\* Sur demande  
P<sub>GA</sub> (kW) Réducteurs sans refroidissement supplémentaire \*\*  
P<sub>GB</sub> (kW) Réducteurs avec ventilateur \*\*  
P<sub>GC</sub> (kW) Réducteurs avec serpentin intégré \*\* \*\*\*  
P<sub>GD</sub> (kW) Réducteurs avec ventilateur et serpentin intégré \*\* \*\*\*

\*\* Les valeurs sont valables pour:  
Durée d'utilisation: 100 %  
Implantation dans un grand hall  
Altitude jusqu'à 1000 m  
\*\*\* Les données sont valables pour une température d'eau de refroidissement en entrée de 20 °C sans limitation de la température de l'eau en sortie.  
Un calcul avec limitation de la température d'eau en sortie est possible sur demande.

# Zahnradgetriebe

Wärmegrenzleistungen

Bauart H1..

Größen 3 - 26

$n_1 = 1500 \text{ min}^{-1}$

# Gear Units

Thermal Capacities

Type H1..

Sizes 3 - 26

$n_1 = 1500 \text{ min}^{-1}$

# Réducteurs à engrenages

Capacités thermiques

Type H1..

Tailles 3 - 26

$n_1 = 1500 \text{ min}^{-1}$

Wärmegrenzleistungen  $P_G$  (kW) / Thermal capacities  $P_G$  (kW) / Capacités thermiques  $P_G$  (kW)

$i_N$		Getriebegrößen / Gear unit sizes / Tailles réducteurs																							
		3	4	5	6	7	8	9	10	11	12	13	14	15	16	17	18	19	20	21	22	23	24	25	26
1.25	$P_{GA}$	*		*		*		*																	
	$P_{GB}$	210		372		408		*																	
	$P_{GC}$	307		686		946		1276																	
	$P_{GD}$	472		1117		1537		1991																	
1.4	$P_{GA}$	*		*		*		*																	
	$P_{GB}$	212		392		447		375																	
	$P_{GC}$	299		680		937		1285																	
	$P_{GD}$	459		1104		1523		1992																	
1.6	$P_{GA}$	*		*		*		*		*		*		*		*		*		*		*		*	
	$P_{GB}$	213		420		500		495		*		*		*		*		*		*		*		*	
	$P_{GC}$	284		655		894		1276		1944		2060		*		*		*		*		*		*	
	$P_{GD}$	438		1063		1452		1982		3039		3187		*		*		*		*		*		*	
1.8	$P_{GA}$	*		*		*		*		*		*		*		*		*		*		*		*	
	$P_{GB}$	241		435		554		575		*		*		*		*		*		*		*		*	
	$P_{GC}$	309		625		894		1259		1990		2161		*		*		*		*		*		*	
	$P_{GD}$	478		1019		1450		1953		3106		3328		*		*		*		*		*		*	
2	$P_{GA}$	*		*		*		*		*		*		*		*		*		*		*		*	
	$P_{GB}$	234		427		553		590		509		*		*		*		*		*		*		*	
	$P_{GC}$	295		593		852		1207		1947		2161		1626		*		*		*		*		*	
	$P_{GD}$	455		964		1382		1873		3026		3313		2826		*		*		*		*		*	
2.24	$P_{GA}$	*		*		*		*		*		*		*		*		*		*		*		*	
	$P_{GB}$	227		422		544		620		631		*		*		*		*		*		*		*	
	$P_{GC}$	278		558		779		1151		1902		2172		1719		*		*		*		*		*	
	$P_{GD}$	431		913		1264		1790		2964		3336		2963		*		*		*		*		*	
2.5	$P_{GA}$	*		*		*		*		*		*		*		*		*		*		*		*	
	$P_{GB}$	211		405		525		614		676		*		*		*		*		*		*		*	
	$P_{GC}$	251		518		723		1075		1810		2102		1746		*		*		*		*		*	
	$P_{GD}$	388		848		1172		1674		2819		3228		2972		*		*		*		*		*	
2.8	$P_{GA}$	50		*		*		*		*		*		*		*		*		*		*		*	
	$P_{GB}$	199		384		553		658		705		*		*		*		*		*		*		*	
	$P_{GC}$	231		475		733		1091		1698		2002		1748		1836		*		*		*		*	
	$P_{GD}$	359		777		1189		1695		2647		3075		2947		3087		*		*		*		*	
3.15	$P_{GA}$	63.8		*		*		*		*		*		*		*		*		*		*		*	
	$P_{GB}$	200		415		702		828		1055		1033		816		*		*		*		*		*	
	$P_{GC}$	226		481		881		1237		1858		2221		2223		2487		*		*		*		*	
	$P_{GD}$	348		779		1442		1941		2879		3394		3634		4035		*		*		*		*	
3.55	$P_{GA}$	59.8		*		*		*		*		*		*		*		*		*		*		*	
	$P_{GB}$	183		407		649		778		998		1014		860		678		*		*		*		*	
	$P_{GC}$	204		460		791		1124		1685		2042		2087		2387		*		*		*		*	
	$P_{GD}$	314		746		1301		1768		2617		3123		3397		3839		*		*		*		*	
4	$P_{GA}$	56.2		85.1		*		*		*		*		*		*		*		*		*		*	
	$P_{GB}$	166		374		591		677		964		1012		938		821		623		*		*		*	
	$P_{GC}$	181		410		696		937		1534		1870		1943		2263		*		*		*		*	
	$P_{GD}$	280		665		1147		1483		2387		2866		3159		3625		*		*		*		*	
4.5	$P_{GA}$	66.4		106		135		*		*		*		*		*		*		*		*		*	
	$P_{GB}$	180		389		611		795		994		1193		1261		1192		1069		*		*		*	
	$P_{GC}$	194		413		696		1049		1489		1992		2075		2382		*		*		*		*	
	$P_{GD}$	298		669		1137		1646		2330		3062		3339		3779		*		*		*		*	
5	$P_{GA}$	62.5		111		151		169		*		*		*		*		*		*		*		*	
	$P_{GB}$	165		373		599		738		1020		1227		1395		1560		1526		*		*		*	
	$P_{GC}$	173		390		659		930		1427		1911		2022		2660		*		*		*		*	
	$P_{GD}$	266		631		1080		1464		2242		2942		3255		4202		*		*		*		*	
5.6	$P_{GA}$	56		98.8		136		163		*		*		*		*		*		*		*		*	
	$P_{GB}$	146		330		535		704		967		1104		1266		1433		1604		*		*		*	
	$P_{GC}$	151		337		577		866		1337		1675		1787		2367		*		*		*		*	
	$P_{GD}$	232		548		949		1370		2106		2586		2880		3741		*		*		*		*	

\* Auf Anfrage  
 $P_{GA}$  (kW) Getriebe ohne Zusatzkühlung \*\*  
 $P_{GB}$  (kW) Getriebe mit Lüfterkühlung \*\*  
 $P_{GC}$  (kW) Getriebe mit eingebauter Kühle-  
 schlange \*\* \*\*\*)  
 $P_{GD}$  (kW) Getriebe mit Lüfter und eingebauter  
 Kühle-  
 schlange \*\* \*\*\*)

\*\* Werte gelten für:  
 Einschaltdauer: 100 %  
 Aufstellung in großer Halle  
 Höhenlage bis 1000 m  
 \*\*\*) Werte gelten für eine Kühlwassereintritts-  
 temperatur von 20 °C ohne Begrenzung der  
 Kühlwasseraustrittstemperatur.  
 Die Nachrechnung mit Begrenzung der Kühl-  
 wasseraustrittstemperatur ist auf Anfrage  
 möglich.

\* On request  
 $P_{GA}$  (kW) Gear units without auxiliary  
 cooling \*\*  
 $P_{GB}$  (kW) Gear units with fan \*\*  
 $P_{GC}$  (kW) Gear units with built-in cooling  
 coil \*\* \*\*\*)  
 $P_{GD}$  (kW) Gear units with fan and built-in  
 cooling coil \*\* \*\*\*)

\*\* Values refer to:  
 Operating cycle: 100 %  
 Installation in a large hall  
 Altitude up to 1000 m  
 \*\*\*) Values refer to a cooling water inlet tempe-  
 rature of 20 °C with unlimited cooling water  
 outlet temperature.  
 A recalculation with a limited cooling water  
 outlet temperature is possible on request.

\* Sur demande  
 $P_{GA}$  (kW) Réducteurs sans refroidissement  
 supplémentaire \*\*  
 $P_{GB}$  (kW) Réducteurs avec ventilateur \*\*  
 $P_{GC}$  (kW) Réducteurs avec serpentin  
 intégré \*\* \*\*\*)  
 $P_{GD}$  (kW) Réducteurs avec ventilateur et  
 serpentin intégré \*\* \*\*\*)

\*\* Les valeurs sont valables pour:  
 Durée d'utilisation: 100 %  
 Implantation dans un grand hall  
 Altitude jusqu'à 1000 m  
 \*\*\*) Les données sont valables pour une tempé-  
 rature d'eau de refroidissement en entrée  
 de 20 °C sans limitation de la température  
 de l'eau en sortie.  
 Un calcul avec limitation de la température  
 d'eau en sortie est possible sur demande.



## Zahnradgetriebe

Wärmegrenzleistungen

Bauart H1..

Größen 3 - 26

$n_1 = 1800 \text{ min}^{-1}$

## Gear Units

Thermal Capacities

Type H1..

Sizes 3 - 26

$n_1 = 1800 \text{ min}^{-1}$

## Réducteurs à engrenages

Capacités thermiques

Type H1..

Tailles 3 - 26

$n_1 = 1800 \text{ min}^{-1}$

Wärmegrenzleistungen P <sub>G</sub> (kW) / Thermal capacities P <sub>G</sub> (kW) / Capacités thermiques P <sub>G</sub> (kW)																									
i <sub>N</sub>		Getriebegrößen / Gear unit sizes / Tailles réducteurs																							
		3	4	5	6	7	8	9	10	11	12	13	14	15	16	17	18	19	20	21	22	23	24	25	26
1.25	P <sub>GA</sub>	*		*		*		*																	
	P <sub>GB</sub>	210		295		*		*																	
	P <sub>GC</sub>	314		650		851		1058																	
	P <sub>GD</sub>	514		1164		1554		1921																	
1.4	P <sub>GA</sub>	*		*		*		*																	
	P <sub>GB</sub>	214		327		300		*																	
	P <sub>GC</sub>	308		652		859		1096																	
	P <sub>GD</sub>	502		1158		1556		1953																	
1.6	P <sub>GA</sub>	*		*		*		*																	
	P <sub>GB</sub>	219		379		397		*		*		*													
	P <sub>GC</sub>	294		643		848		1146		1465		*													
	P <sub>GD</sub>	482		1131		1513		2002		2784		2485													
1.8	P <sub>GA</sub>	*		*		*		*		*		*													
	P <sub>GB</sub>	252		411		480		420		*		*													
	P <sub>GC</sub>	323		623		867		1171		1625		1428													
	P <sub>GD</sub>	527		1095		1531		2012		2972		2848													
2	P <sub>GA</sub>	*		*		*		*		*		*		*		*		*		*					
	P <sub>GB</sub>	245		409		491		454		*		*		*		*		*		*					
	P <sub>GC</sub>	308		595		833		1135		1628		1503		*		*		*		*					
	P <sub>GD</sub>	503		1039		1467		1943		2934		2909		1973		*		*		*					
2.24	P <sub>GA</sub>	*		*		*		*		*		*		*		*		*		*					
	P <sub>GB</sub>	240		414		504		519		*		*		*		*		*		*					
	P <sub>GC</sub>	292		566		773		1105		1661		1651		*		*		*		*					
	P <sub>GD</sub>	478		990		1352		1879		2945		3070		2319		*		*		*					
2.5	P <sub>GA</sub>	*		*		*		*		*		*		*		*		*		*					
	P <sub>GB</sub>	224		402		496		532		*		*		*		*		*		*					
	P <sub>GC</sub>	264		528		722		1043		1613		1661		*		*		*		*					
	P <sub>GD</sub>	431		922		1259		1768		2834		3033		2437		*		*		*					
2.8	P <sub>GA</sub>	*		*		*		*		*		*		*		*		*		*					
	P <sub>GB</sub>	212		386		531		589		*		*		*		*		*		*					
	P <sub>GC</sub>	244		486		737		1069		1543		1639		1152		*		*		*					
	P <sub>GD</sub>	399		848		1283		1801		2690		2947		2517		2389		*		*					
3.15	P <sub>GA</sub>	52.3		*		*		*		*		*		*		*		*		*					
	P <sub>GB</sub>	217		438		726		832		967		808		*		*		*		*					
	P <sub>GC</sub>	242		505		915		1268		1835		2097		1942		2051		*		*					
	P <sub>GD</sub>	389		862		1587		2118		3074		3528		3611		3882		*		*					
3.55	P <sub>GA</sub>	50		*		*		*		*		*		*		*		*		*					
	P <sub>GB</sub>	199		431		675		788		930		824		*		*		*		*					
	P <sub>GC</sub>	218		484		824		1156		1674		1947		1853		2012		*		*					
	P <sub>GD</sub>	352		827		1434		1933		2804		3265		3407		3739		*		*					
4	P <sub>GA</sub>	48.7		*		*		*		*		*		*		*		*		*					
	P <sub>GB</sub>	181		398		620		695		926		878		627		*		*		*					
	P <sub>GC</sub>	194		433		728		970		1542		1815		1779		1987		*		*					
	P <sub>GD</sub>	313		739		1268		1628		2575		3028		3225		3613		*		*					
4.5	P <sub>GA</sub>	61		*		*		*		*		*		*		*		*		*					
	P <sub>GB</sub>	198		419		653		837		1005		1142		1081		925		722		*					
	P <sub>GC</sub>	208		439		735		1100		1530		1999		2006		2245		*		*					
	P <sub>GD</sub>	334		746		1265		1822		2547		3300		3520		3924		*		*					
5	P <sub>GA</sub>	59.4		92.5		*		*		*		*		*		*		*		*					
	P <sub>GB</sub>	182		406		646		788		1059		1230		1310		1393		1281		*					
	P <sub>GC</sub>	186		416		700		983		1486		1956		2016		2605		*		*					
	P <sub>GD</sub>	299		706		1206		1628		2471		3208		3494		4463		*		*					
5.6	P <sub>GA</sub>	53.2		82.3		*		*		*		*		*		*		*		*					
	P <sub>GB</sub>	161		358		577		752		1004		1107		1189		1280		1346		*					
	P <sub>GC</sub>	162		360		613		915		1392		1715		1781		2318		*		*					
	P <sub>GD</sub>	261		613		1059		1523		2321		2820		3092		3973		*		*					

\* Auf Anfrage

P<sub>GA</sub> (kW) Getriebe ohne Zusatzkühlung \*\*)

P<sub>GB</sub> (kW) Getriebe mit Lüfterkühlung \*\*)

P<sub>GC</sub> (kW) Getriebe mit eingebauter Kühle-schlange \*\*) \*\*\*)

P<sub>GD</sub> (kW) Getriebe mit Lüfter und eingebauter Kühle-schlange \*\*) \*\*\*)

\*\* Werte gelten für:

Einschaltdauer: 100 %  
Aufstellung in großer Halle  
Höhenlage bis 1000 m

\*\*\*) Werte gelten für eine Kühlwassereintritts-temperatur von 20 °C ohne Begrenzung der Kühlwasseraustritts-temperatur. Die Nachrechnung mit Begrenzung der Kühl-wasseraustritts-temperatur ist auf Anfrage möglich.

\* On request

P<sub>GA</sub> (kW) Gear units without auxiliary cooling \*\*)

P<sub>GB</sub> (kW) Gear units with fan \*\*)

P<sub>GC</sub> (kW) Gear units with built-in cooling coil \*\*) \*\*\*)

P<sub>GD</sub> (kW) Gear units with fan and built-in cooling coil \*\*) \*\*\*)

\*\* Values refer to:

Operating cycle: 100 %  
Installation in a large hall  
Altitude up to 1000 m

\*\*\*) Values refer to a cooling water inlet tempe-rature of 20 °C with unlimited cooling water outlet temperature. A recalculation with a limited cooling water outlet temperature is possible on request.

\* Sur demande

P<sub>GA</sub> (kW) Réducteurs sans refroidissement supplémentaire \*\*)

P<sub>GB</sub> (kW) Réducteurs avec ventilateur \*\*)

P<sub>GC</sub> (kW) Réducteurs avec serpentin intégré \*\*) \*\*\*)

P<sub>GD</sub> (kW) Réducteurs avec ventilateur et serpentin intégré \*\*) \*\*\*)

\*\* Les valeurs sont valables pour:

Durée d'utilisation: 100 %  
Implantation dans un grand hall  
Altitude jusqu'à 1000 m

\*\*\*) Les données sont valables pour une tempé-rature d'eau de refroidissement en entrée de 20 °C sans limitation de la température de l'eau en sortie. Un calcul avec limitation de la température d'eau en sortie est possible sur demande.

### Zahnradgetriebe

Nennleistungen  
Bauart H2..  
Größen 4 - 26

### Gear Units

Nominal Power Ratings  
Type H2..  
Sizes 4 - 26

### Réducteurs à engrenages

Puissances nominales  
Type H2..  
Tailles 4 - 26

Nennleistungen P <sub>2N</sub> (kW) / Nominal power ratings P <sub>2N</sub> (kW) / Puissances nominales P <sub>2N</sub> (kW)																								
i <sub>N</sub>	n <sub>1</sub>	n <sub>2</sub>	Getriebegrößen / Gear unit sizes / Tailles réducteurs																					
			4	5	6	7	8	9	10	11	12	13	14	15	16	17	18	19	20	21	22	23	24	25
6.3	1800	286	188	320		607		1009		1775		2575		4282*										
	1500	238	157	266		505		839		1477		2143		3563		4859								
	1200	190	125	212		403		670		1179		1710		2845		3879								
	1000	159	104	178		337		561		987		1431		2380		3246		4861						
7.1	1800	254	172	297		539		896		1577		2287		3803*	4255*									
	1500	211	143	247		448		744		1310		1900		3159	3535	4308								
	1200	169	115	198		359		596		1049		1521		2530	2831	3450	4070							
	1000	141	95	165		299		497		875		1269		2111	2362	2879	3395	4311	4946					
8	1800	225	157	263	318	478	603	793	994	1397	1738	2026	2520	3369*	3769*	4594*								
	1500	188	131	220	265	399	503	663	830	1167	1452	1692	2106	2815	3149	3838	4527							
	1200	150	105	175	212	318	402	529	662	931	1159	1350	1680	2246	2513	3062	3612	4586*						
	1000	125	87	146	176	265	335	441	552	776	965	1125	1400	1871	2094	2552	3010	3821	4384					
9	1800	200	140	234	301	425	536	705	883	1241	1545	1801	2240	2994*	3350*	4083*	4816*							
	1500	167	117	195	251	354	447	589	737	1036	1290	1503	1871	2500	2797	3409	4021							
	1200	133	93	155	200	282	356	469	587	825	1027	1197	1490	1991	2228	2715	3203	4066*	4665*					
	1000	111	77	130	167	235	297	391	490	689	857	999	1243	1662	1859	2266	2673	3393	3893	4765				
10	1800	180	118	197	271	382	482	635	795	1117	1390	1620	2016	2695*	3015*	3675*	4335*							
	1500	150	98	164	226	318	402	529	662	931	1159	1350	1680	2246	2513	3062	3612	4586*						
	1200	120	79	131	180	255	321	423	530	745	927	1080	1344	1796	2010	2450	2890	3669*	4209*					
	1000	100	65	109	150	212	268	352	441	620	772	900	1120	1497	1675	2041	2408	3057	3507	4293	4795			
11.2	1800	161	106	178	242	342	431	568	711	999	1244	1449	1803	2410*	2697*	3287*	3877*	4922*						
	1500	134	88	148	202	284	359	472	592	832	1035	1206	1501	2006	2245	2736	3227	4097*	4700*					
	1200	107	70	118	161	227	286	377	472	664	826	963	1198	1602	1792	2184	2576	3271*	3753*	4593*				
	1000	89	58	98	134	189	238	314	393	552	687	801	997	1332	1491	1817	2143	2721	3121	3820	4268			
12.5	1800	144	101	168	203	304	386	508	636	894	1112	1296	1613	2156*	2412*	2940*	3468*	4402*						
	1500	120	84	140	169	253	321	423	530	745	927	1080	1344	1796	2010	2450	2890	3669	4209*					
	1200	96	67	112	135	203	257	338	424	596	741	864	1075	1437	1608	1960	2312	2935	3367*	4121*	4603*			
	1000	80	56	93	113	169	214	282	353	496	618	720	896	1197	1340	1633	1926	2446	2806	3434	3836	4523		
14	1800	129	90	151	182	274	345	455	570	801	996	1161	1445	1931*	2161*	2634*	3106*	3944*	4525*					
	1500	107	75	125	151	227	286	377	472	664	826	963	1198	1602	1792	2184	2576	3271	3753	4593*				
	1200	86	60	100	121	182	230	303	380	534	664	774	963	1287	1440	1756	2071	2629	3016	3692*	4124*	4862*		
	1000	71	49	83	100	150	190	250	313	440	548	639	795	1063	1189	1449	1709	2170	2490	3048	3405	4014	4609	
16	1800	113	79	132	170	240	301	398	499	701	873	1017	1266	1692*	1893*	2307*	2721*	3455*	3963*	4851*				
	1500	94	65	110	141	199	250	331	415	583	726	846	1053	1407	1574	1919	2263	2874	3297	4035*	4508*			
	1200	75	52	87	113	159	200	264	331	465	579	675	840	1123	1256	1531	1806	2293	2630	3219*	3596*	4240*	4869*	
	1000	63	44	73	94	133	168	222	278	391	486	567	705	943	1055	1286	1517	1926	2209	2704	3021	3562	4090	
18	1800	100	65	109	150	198	268	352	441	620	772	900	1120	1497*	1675*	2041*	2408*	3057*	3507*	4293*	4795*			
	1500	83	54	91	125	165	222	292	366	515	641	747	929	1242	1390	1694	1998	2537	2911	3563*	3980*	4693*		
	1200	67	44	73	101	133	179	236	296	416	517	603	750	1003	1122	1368	1613	2048	2350	2876*	3213*	3788*	4349*	
	1000	56	36	61	84	111	150	197	247	347	432	504	627	838	938	1143	1348	1712	1964	2404	2685	3166	3635	4573
20	1800	90	62	105	135	179	241	317	397	558	695	810	1008	1347*	1507*	1837*	2167*	2751*	3157*	3863*	4316*			
	1500	75	51	87	113	149	201	264	331	465	579	675	840	1123	1256	1531	1806	2293	2630	3219*	3596*	4240*	4869*	
	1200	60	41	70	90	119	160	211	265	372	463	540	672	898	1005	1225	1445	1834	2104	2575*	2877*	3392*	3895*	4900*
	1000	50	34	58	75	99	134	176	220	310	386	450	560	748	837	1020	1204	1528	1753	2146	2397	2827	3246	4083
22.4	1800	80	52	91	113	165	201	277	353	488	618		896		1340*		1926*		2806*		3836*			
	1500	67	44	76	94	138	168	232	296	409	517		750		1122		1613		2350		3213*		4349*	
	1200	54	35	61	76	111	135	187	238	329	417		605		904		1300		1894		2589*		3505*	4975*
	1000	45	29	51	63	93	113	155	198	274	347		504		753		1083		1578		2158		2921	4146
25	1800	72			107		180		318		556		806											
	1500	60			89		150		265		463		672											
	1200	48			71		120		212		370		537											
	1000	40			59		100		176		309		448											
28	1800	64			93		167		278		485													
	1500	54			78		141		235		409													
	1200	43			62		112		187		326													
	1000	36			52		94		156		273													

Druckschmierung bei Horizontalgetrieben erforderlich

Forced lubrication required on horizontal gear units

La lubrification sous pression est nécessaire en position horizontale pour ces réducteurs

\* Getriebe nur auf Anfrage

\* Gear units only on request

\* Réducteur à engrenages seulement sur demande

# Zahnradgetriebe

Nenn-Abtriebsdrehmomente  
Bauart H2..  
Größen 4 - 26

# Gear Units

Nominal Output Torques  
Type H2..  
Sizes 4 - 26

# Réducteurs à engrenages

Couples nominaux de sortie  
Type H2..  
Tailles 4 - 26

Nenn-Abtriebsdrehmomente $T_{2N}$ (kNm) Nominal output torques $T_{2N}$ (kNm) / Couples nominaux de sortie $T_{2N}$ (kNm)																								
$i_N$	Getriebegrößen / Gear unit sizes / Tailles réducteurs																							
	3	4	5	6	7	8	9	10	11	12	13	14	15	16	17	18	19	20	21	22	23	24	25	26
1.25	2.9		8		15.2		24.7																	
1.4	3.1		8.2		15.9		25.6																	
1.6	3.3		8.6		16.3		27.1		46		67.4													
1.8	2.7		8.8		17.4		28		47.6		70.9													
2	2.8		9.4		17.8		28.7		49.1		72.9		129											
2.24	2.8		9.6		17.8		28.7		50.6		75.2		130											
2.5	2.9		9.6		17.8		28.7		50.6		77													
2.8	3.1		9.6		17.1		27.4		50.6		77		120											
3.15	3.1		9.6		17.4		28.7		48.1		73.1		124											
3.55	3.2		9.5		17.8		28.6		50.2		74.4		126											
4	3.2		9.6		17.8		28.7		50.6		75.7		130		173		245							
4.5	2.5		7.7		15.8		24.6		46		61.6		109		146		216							
5	2.4		7.2		13.8		23.5		38.7		58.3		95		124		174							
5.6	2.3		6.9		13.1		20.1		36.5		55.4		90.4		118		150							
6.3		6.3	10.7		20.3		33.7		59.3		86		143		195		292							
7.1		6.5	11.2		20.3		33.7		59.3		86		143	160	195	230	292	335	410					
8		6.7	11.2	13.5	20.3	25.6	33.7	42.2	59.3	73.8	86	107	143	160	195	230	292	335	410	458				
9		6.7	11.2	14.4	20.3	25.6	33.7	42.2	59.3	73.8	86	107	143	160	195	230	292	335	410	458	540			
10		6.3	10.5	14.4	20.3	25.6	33.7	42.2	59.3	73.8	86	107	143	160	195	230	292	335	410	458	540	620		
11.2		6.3	10.6	14.4	20.3	25.6	33.7	42.2	59.3	73.8	86	107	143	160	195	230	292	335	410	458	540	620	780	
12.5		6.7	11.2	13.5	20.2	25.6	33.7	42.2	59.3	73.8	86	107	143	160	195	230	292	335	410	458	540	620	780	880
14		6.7	11.2	13.5	20.3	25.6	33.7	42.2	59.3	73.8	86	107	143	160	195	230	292	335	410	458	540	620	780	880
16		6.7	11.2	14.4	20.3	25.5	33.7	42.2	59.3	73.8	86	107	143	160	195	230	292	335	410	458	540	620	780	880
18		6.3	10.5	14.4	19	25.6	33.7	42.2	59.3	73.8	86	107	143	160	195	230	292	335	410	458	540	620	780	880
20		6.6	11.2	14.4	19	25.6	33.7	42.2	59.3	73.8	86	107	143	160	195	230	292	335	410	458	540	620	780	880
22.4		6.3	10.9	13.5	19.8	24	33.1	42.2	58.3	73.8	88	107	153	160	200	230	300	335	420	458	560	620	800	880
25			11.6	14.3	21.7	24	35.7	42.2	63.5	73.8	88	107	153	173	200	240	300	345	420	470	560	640	800	900
28			11.6	13.9	21.7	25	35.7	41.6	63.5	72.5	88	109	153	173	200	240	300	345	420	470	560	640	800	900
31.5			11.6	15.5	21.7	27.2	35.7	43.8	63.5	77.2	88	109	153	173	200	240	300	345	420	470	560	640	800	900
35.5			11.6	15.5	21.7	27.2	35.7	43.8	63.5	77.2	88	109	153	173	200	240	300	345	420	470	560	640	800	900
40			11.6	15.5	21.7	27.2	35.7	43.8	63.5	77.2	88	109	153	173	200	240	300	345	420	470	560	640	800	900
45			11.6	15.5	21.7	27.2	35.7	43.8	63.5	77.2	88	109	153	173	200	240	300	345	420	470	560	640	800	900
50			11.6	15.5	21.7	27.2	35.7	43.8	63.5	77.2	88	109	153	173	200	240	300	345	420	470	560	640	800	900
56			11.6	15.5	21.7	27.2	35.7	43.8	63.5	77.2	88	109	153	173	200	240	300	345	420	470	560	640	800	900
63			11.6	15.5	21.7	27.2	35.7	43.8	63.5	77.2	88	109	153	173	200	240	300	345	420	470	560	640	800	900
71			11.6	15.5	21.7	27.2	35.7	43.8	63.5	77.2	88	109	153	173	200	240	300	345	420	470	560	640	800	900
80			11.6	15.5	21.7	27.2	35.7	43.8	63.5	77.2	88	109	153	173	200	240	300	345	420	470	560	640	800	900
90			11.6	15.5	20	27.2	34.5	43.8	63.5	77.2	88	109	153	173	200	240	290	345	410	470	560	640	800	900
100				14.5	21.7	27.2	35.7	43.8	61.6	77.2	90.7	109	153	173	200	226	300	335	420	465	560	640	800	900
112				15	21.7	25.2	35.7	42.8	61.6	77.2	90.7	109	153	173	200	240	300	345	420	470	560	640	800	900
125					21.7	27.2	35.7	44.2	61.6	78	90.7	113	153	173	200	240	300	345	420	470	560	640	800	900
140					21.7	27.2	35.7	44.2	61.6	78	90.7	113	153	173	200	240	300	345	420	470	560	640	800	900
160					21.7	27.2	35.7	44.2	61.6	78	90.7	113	153	173	200	240	300	345	420	470	560	640	800	900
180					21.7	27.2	35.7	44.2	61.6	78	90.7	113	153	173	200	240	300	345	420	470	560	640	800	900
200					21.7	27.2	35.7	44.2	61.6	78	90.7	113	153	173	200	240	300	345	420	470	560	640	800	900
224					21.7	27.2	35.7	44.2	61.6	78	90.7	113	153	173	200	240	300	345	420	470	560	640	800	900
250					21.7	27.2	35.7	44.2	61.6	78	90.7	113	153	173	200	240	300	345	420	470	560	640	800	900
280					21.7	27.2	35.7	44.2	61.6	78	90.7	113	153	173	200	240	300	345	420	470	560	640	800	900
315					21.7	27.2	35.7	44.2	61.6	78	90.7	113	153	173	200	240	300	345	420	470	560	640	800	900
355					19.6	27.2	35.7	44.2	61.6	78	90.7	113	140	173	192	240	290	345	410	470	560	640	800	900
400						27.2		44.2		78		113		158		223		335		465		640		900
450						25.3		42.8		78		113												

**H1**

siehe Seiten 16 - 21  
see pages 16 - 21  
voir pages 16 - 21

**H3**

siehe Seiten 28 - 33  
see pages 28 - 33  
voir pages 28 - 33

**H4**

siehe Seiten 34 - 37  
see pages 34 - 37  
voir pages 34 - 37

# Zahnradgetriebe

Wärmegrenzleistungen

Bauart H2..

Größen 4 - 26

$n_1 = 1000 \text{ min}^{-1}$

# Gear Units

Thermal Capacities

Type H2..

Sizes 4 - 26

$n_1 = 1000 \text{ min}^{-1}$

# Réducteurs à engrenages

Capacités thermiques

Type H2..

Tailles 4 - 26

$n_1 = 1000 \text{ min}^{-1}$

Wärmegrenzleistungen  $P_G$  (kW) / Thermal capacities  $P_G$  (kW) / Capacités thermiques  $P_G$  (kW)

$i_N$		Getriebegrößen / Gear unit sizes / Tailles réducteurs																									
		4	5	6	7	8	9	10	11	12	13	14	15	16	17	18	19	20	21	22	23	24	25	26			
6.3	$P_{GA}$	54.1	66.5		90.3		116		134		*		*		*		*		*		*		*		*		
	$P_{GB}$	106	143		221		293		450		579		563		625		*		*		*		*		*		
	$P_{GC}$	120	190		305		475		696		1201		1434		1736		*		*		*		*		*		
	$P_{GD}$	162	256		417		626		951		1553		1782		2240		*		*		*		*		*		
7.1	$P_{GA}$	56.1	69		89.8		117		145		*		*		*		*		*		*		*		*		
	$P_{GB}$	109	146		214		286		454		588		591	589	683	659	*	*	*	*	*	*	*	*	*		
	$P_{GC}$	121	189		287		447		677		1163		1392	1448	1689	1737	*	*	*	*	*	*	*	*	*		
	$P_{GD}$	165	256		394		589		931		1510		1746	1810	2186	2260	*	*	*	*	*	*	*	*	*		
8	$P_{GA}$	54.4	68.3	74.5	89.1	99	118	120	152	161	*	*	*	*	*	*	*	*	*	*	*	*	*	*	*		
	$P_{GB}$	104	142	157	208	235	279	290	449	509	591	656	613	620	733	719	*	*	*	*	*	*	*	*	*		
	$P_{GC}$	115	182	197	272	312	425	472	646	884	1110	1263	1348	1407	1649	1693	*	*	*	*	*	*	*	*	*		
	$P_{GD}$	155	245	266	376	428	562	618	895	1170	1455	1658	1696	1772	2154	2203	*	*	*	*	*	*	*	*	*		
9	$P_{GA}$	53.4	67.9	78.1	89.3	100	120	124	160	182	195	212	*	*	*	*	*	*	*	*	*	*	*	*	*		
	$P_{GB}$	101	139	159	202	228	272	283	437	520	594	672	635	655	786	789	*	*	*	*	*	*	*	*	*		
	$P_{GC}$	109	174	197	259	294	403	442	599	861	1055	1224	1292	1366	1611	1662	*	*	*	*	*	*	*	*	*		
	$P_{GD}$	150	234	266	357	405	536	582	833	1149	1395	1611	1644	1736	2120	2191	*	*	*	*	*	*	*	*	*		
10	$P_{GA}$	51.1	65.4	77.4	88.3	100	119	125	164	193	209	234	200	198	*	*	*	*	*	*	*	*	*	*	*		
	$P_{GB}$	95.7	131	156	193	222	262	278	424	516	587	673	640	668	812	830	*	*	*	*	*	*	*	*	*		
	$P_{GC}$	102	160	189	243	280	378	422	564	821	999	1167	1224	1303	1548	1611	*	*	*	*	*	*	*	*	*		
	$P_{GD}$	139	217	255	337	386	505	556	786	1106	1326	1551	1571	1674	2053	2143	*	*	*	*	*	*	*	*	*		
11.2	$P_{GA}$	49.3	63.4	76	90.7	99	116	124	173	195	226	247	218	222	229	223	*	*	*	*	*	*	*	*	*		
	$P_{GB}$	91.7	126	151	196	214	249	270	430	495	601	665	632	669	815	847	*	*	*	*	*	*	*	*	*		
	$P_{GC}$	97	151	180	241	264	353	398	560	756	986	1113	1148	1237	1468	1553	*	*	*	*	*	*	*	*	*		
	$P_{GD}$	132	205	245	336	367	473	528	784	1020	1319	1482	1485	1594	1958	2070	*	*	*	*	*	*	*	*	*		
12.5	$P_{GA}$	47.8	63	72.3	90.2	95.6	116	122	178	194	226	252	235	235	260	250	301	289	*	*	*	*	*	*	*		
	$P_{GB}$	87.6	123	142	191	205	244	259	425	475	572	648	637	656	833	844	*	*	*	*	*	*	*	*	*		
	$P_{GC}$	93.6	149	165	236	250	342	375	549	710	906	1046	1128	1164	1430	1470	*	*	*	*	*	*	*	*	*		
	$P_{GD}$	126	201	226	327	346	455	498	766	960	1212	1401	1459	1506	1914	1965	*	*	*	*	*	*	*	*	*		
14	$P_{GA}$	45.5	60	69.8	83.8	97.7	114	119	173	202	225	266	240	252	274	281	328	333	*	*	*	*	*	*	*		
	$P_{GB}$	82.9	116	135	175	207	236	247	403	483	547	659	614	659	814	860	*	*	*	*	*	*	*	*	*		
	$P_{GC}$	87.5	138	156	211	248	322	349	509	705	840	1037	1049	1138	1339	1431	*	*	*	*	*	*	*	*	*		
	$P_{GD}$	118	186	213	294	345	432	465	711	958	1131	1392	1365	1482	1802	1921	*	*	*	*	*	*	*	*	*		
16	$P_{GA}$	41.8	56.6	68.9	79	97	108	117	166	206	212	263	252	254	280	292	341	354	336	*	*	*	*	*	*		
	$P_{GB}$	75.7	108	131	163	201	221	240	377	476	501	626	617	634	782	837	*	*	*	*	*	*	*	*	*		
	$P_{GC}$	78.8	126	154	194	242	295	339	464	688	744	947	1027	1059	1245	1341	*	*	*	*	*	*	*	*	*		
	$P_{GD}$	107	171	208	269	336	397	449	650	932	1007	1276	1341	1381	1680	1810	*	*	*	*	*	*	*	*	*		
18	$P_{GA}$	40.1	54.4	65.7	76.1	89.7	103	114	156	200	219	259	248	268	292	299	362	368	367	352	*	*	*	*	*		
	$P_{GB}$	72.1	103	124	157	184	208	231	352	450	506	598	583	638	768	805	*	*	*	*	*	*	*	*	*		
	$P_{GC}$	74.1	119	142	185	217	276	319	432	635	747	881	947	1037	1189	1243	*	*	*	*	*	*	*	*	*		
	$P_{GD}$	100	162	194	257	301	371	425	609	864	1009	1189	1244	1359	1606	1689	*	*	*	*	*	*	*	*	*		
20	$P_{GA}$	39.3	51.1	61.7	71.3	85.2	100	109	152	189	208	239	242	258	293	304	361	378	373	372	*	*	*	*	*		
	$P_{GB}$	70.2	96.8	115	145	172	200	217	339	419	473	543	554	599	751	787	*	*	*	*	*	*	*	*	*		
	$P_{GC}$	71.7	111	131	169	199	264	293	408	577	681	780	871	957	1140	1181	*	*	*	*	*	*	*	*	*		
	$P_{GD}$	97.4	150	179	236	276	355	392	575	786	923	1056	1142	1257	1546	1602	*	*	*	*	*	*	*	*	*		
22.4	$P_{GA}$	36.4	47.5	59	68.7	81.1	92.3	102	142	175		241		248		300		369		362	*	*	*	*	*		
	$P_{GB}$	64.9	89.4	111	139	165	185	203	314	390		544		566		764					*	*	*	*	*		
	$P_{GC}$	65.3	101	124	161	190	238	273	371	540		780		877		1133		*		*	*	*	*	*	*		
	$P_{GD}$	88.9	137	169	224	263	320	366	524	736		1057		1153		1537		*		*	*	*	*	*	*		
25	$P_{GA}$			55.3		75.8		99.4		170		227															
	$P_{GB}$			103		152		196		374		506															
	$P_{GC}$			114		174		262		506		713															
	$P_{GD}$			156		242		350		692		965															
28	$P_{GA}$			51.5		73.3		92.5		160																	
	$P_{GB}$			95.8		146		182		347																	
	$P_{GC}$			104		166		236		459																	
	$P_{GD}$			142		230		318		630																	

\* Auf Anfrage

$P_{GA}$  (kW) Getriebe ohne Zusatzkühlung \*\*)

$P_{GB}$  (kW) Getriebe mit Lüfterkühlung \*\*)

$P_{GC}$  (kW) Getriebe mit eingebauter Kühltorschlange \*\*\*) \*\*\*)

$P_{GD}$  (kW) Getriebe mit Lüfter und eingebauter Kühltorschlange \*\*\*) \*\*\*)

\*\*) Werte gelten für:  
Einschaltdauer: 100 %  
Aufstellung in großer Halle  
Höhenlage bis 1000 m

\*\*\*) Werte gelten für eine Kühlwassereintrittstemperatur von 20 °C ohne Begrenzung der Kühlwasseraustrittstemperatur.  
Die Nachrechnung mit Begrenzung der Kühlwasseraustrittstemperatur ist auf Anfrage möglich.

\* On request

$P_{GA}$  (kW) Gear units without auxiliary cooling \*\*)

$P_{GB}$  (kW) Gear units with fan \*\*)

$P_{GC}$  (kW) Gear units with built-in cooling coil \*\*\*) \*\*\*)

$P_{GD}$  (kW) Gear units with fan and built-in cooling coil \*\*\*) \*\*\*)

\*\*) Values refer to:  
Operating cycle: 100 %  
Installation in a large hall  
Altitude up to 1000 m

\*\*\*) Values refer to a cooling water inlet temperature of 20 °C with unlimited cooling water outlet temperature.  
A recalculation with a limited cooling water outlet temperature is possible on request.

\* Sur demande

$P_{GA}$  (kW) Réducteurs sans refroidissement supplémentaire \*\*)

$P_{GB}$  (kW) Réducteurs avec ventilateur \*\*)

$P_{GC}$  (kW) Réducteurs avec serpentin intégré \*\*\*) \*\*\*)

$P_{GD}$  (kW) Réducteurs avec ventilateur et serpentin intégré \*\*\*) \*\*\*)

\*\*) Les valeurs sont valables pour:  
Durée d'utilisation: 100 %  
Implantation dans un grand hall  
Altitude jusqu'à 1000 m

\*\*\*) Les données sont valables pour une température d'eau de refroidissement en entrée de 20 °C sans limitation de la température de l'eau en sortie.  
Un calcul avec limitation de la température d'eau en sortie est possible sur demande.

# Zahnradgetriebe

Wärmegrenzleistungen

Bauart H2..

Größen 4 - 26

$n_1 = 1200 \text{ min}^{-1}$

# Gear Units

Thermal Capacities

Type H2..

Sizes 4 - 26

$n_1 = 1200 \text{ min}^{-1}$

# Réducteurs à engrenages

Capacités thermiques

Type H2..

Tailles 4 - 26

$n_1 = 1200 \text{ min}^{-1}$

Wärmegrenzleistungen P <sub>G</sub> (kW) / Thermal capacities P <sub>G</sub> (kW) / Capacités thermiques P <sub>G</sub> (kW)																								
i <sub>N</sub>		Getriebegrößen / Gear unit sizes / Tailles réducteurs																						
		4	5	6	7	8	9	10	11	12	13	14	15	16	17	18	19	20	21	22	23	24	25	26
6.3	P <sub>GA</sub>	49.2	54.6		67.4		*		*		*		*		*		*		*		*		*	
	P <sub>GB</sub>	112	146		220		279		382		415		*		*		*		*		*		*	
	P <sub>GC</sub>	126	196		311		475		665		1088		1192		1360		*		*		*		*	
	P <sub>GD</sub>	176	276		445		658		966		1515		1628		1954		*		*		*		*	
7.1	P <sub>GA</sub>	51.8	58.4		70.3		*		*		*		*		*		*		*		*		*	
	P <sub>GB</sub>	116	151		215		278		400		452		344	*	*		*		*		*		*	
	P <sub>GC</sub>	127	196		294		451		656		1075		1196	1220	1380	1383	*		*		*		*	
	P <sub>GD</sub>	180	276		422		624		956		1497		1636	1670	1971	1997	*		*		*		*	
8	P <sub>GA</sub>	50.9	59.5	63.6	72.9	77.3	88	*	*	*	*	*	*	*	*	*	*	*	*	*	*	*	*	*
	P <sub>GB</sub>	111	149	162	212	236	276	283	410	443	484	526	407	386	*	*	*	*	*	*	*	*	*	*
	P <sub>GC</sub>	121	189	204	281	319	432	477	635	853	1048	1183	1196	1228	1403	1409	*	*	*	*	*	*	*	*
	P <sub>GD</sub>	170	266	288	404	458	599	654	929	1197	1465	1660	1629	1681	2003	2015	*	*	*	*	*	*	*	*
9	P <sub>GA</sub>	51.1	61.6	69.8	77.5	84.3	97.8	97.3	*	*	*	*	*	*	*	*	*	*	*	*	*	*	*	*
	P <sub>GB</sub>	109	147	167	210	234	277	285	419	482	529	589	495	490	552	523	*	*	*	*	*	*	*	*
	P <sub>GC</sub>	116	182	206	269	305	415	453	601	852	1026	1184	1199	1253	1450	1473	*	*	*	*	*	*	*	*
	P <sub>GD</sub>	164	255	289	386	437	576	622	878	1197	1436	1651	1635	1710	2059	2103	*	*	*	*	*	*	*	*
10	P <sub>GA</sub>	49.5	60.9	71.3	79.5	88.1	102	104	121	*	*	*	*	*	*	*	*	*	*	*	*	*	*	*
	P <sub>GB</sub>	103	140	166	204	232	272	285	420	498	549	624	545	554	645	635	*	*	*	*	*	*	*	*
	P <sub>GC</sub>	108	169	198	255	292	392	436	573	825	991	1153	1172	1235	1446	1487	*	*	*	*	*	*	*	*
	P <sub>GD</sub>	153	237	278	367	419	546	599	836	1167	1386	1616	1598	1691	2051	2121	*	*	*	*	*	*	*	*
11.2	P <sub>GA</sub>	48.2	60.1	71.4	83.7	89.7	103	108	138	144	*	*	*	*	*	*	*	*	*	*	*	*	*	*
	P <sub>GB</sub>	100	135	161	208	226	262	281	435	491	582	638	569	591	698	705	*	*	*	*	*	*	*	*
	P <sub>GC</sub>	103	159	190	254	277	369	414	575	769	993	1116	1122	1200	1408	1474	*	*	*	*	*	*	*	*
	P <sub>GD</sub>	145	225	268	366	400	514	572	841	1086	1393	1561	1535	1638	1994	2092	*	*	*	*	*	*	*	*
12.5	P <sub>GA</sub>	47.1	60.4	68.9	84.6	88.4	105	109	149	154	167	*	*	*	*	*	*	*	*	*	*	*	*	*
	P <sub>GB</sub>	95.8	133	153	204	218	258	273	436	480	567	638	596	604	748	742	*	*	*	*	*	*	*	*
	P <sub>GC</sub>	99.8	158	175	249	263	358	393	568	728	921	1061	1118	1147	1396	1423	*	*	*	*	*	*	*	*
	P <sub>GD</sub>	139	220	248	357	378	496	542	825	1029	1289	1487	1524	1566	1976	2017	*	*	*	*	*	*	*	*
14	P <sub>GA</sub>	45.1	58.2	67.3	79.8	92	106	109	151	169	179	207	*	*	*	*	*	*	*	*	*	*	*	*
	P <sub>GB</sub>	90.9	126	147	189	222	252	262	420	496	553	663	593	629	761	792	*	*	*	*	*	*	*	*
	P <sub>GC</sub>	93.4	147	166	223	262	339	367	529	729	862	1062	1055	1138	1328	1410	*	*	*	*	*	*	*	*
	P <sub>GD</sub>	130	204	234	322	377	472	507	770	1032	1211	1489	1440	1557	1883	1998	*	*	*	*	*	*	*	*
16	P <sub>GA</sub>	41.7	55.4	67.1	76.1	92.6	102	109	148	179	176	216	185	*	*	*	*	*	*	*	*	*	*	*
	P <sub>GB</sub>	83.1	118	143	177	216	237	256	397	496	514	640	610	620	754	797	*	*	*	*	*	*	*	*
	P <sub>GC</sub>	84.3	135	164	206	256	312	357	485	716	769	977	1043	1071	1251	1341	*	*	*	*	*	*	*	*
	P <sub>GD</sub>	118	189	229	295	368	435	491	706	1009	1085	1372	1426	1463	1772	1901	*	*	*	*	*	*	*	*
18	P <sub>GA</sub>	40.2	53.7	64.5	74.2	86.8	99	109	144	180	191	223	197	207	217	*	*	*	*	*	*	*	*	*
	P <sub>GB</sub>	79.3	113	136	170	200	225	249	375	474	528	621	590	640	762	790	*	*	*	*	*	*	*	*
	P <sub>GC</sub>	79.3	127	152	196	231	292	337	455	664	778	915	973	1061	1210	1260	*	*	*	*	*	*	*	*
	P <sub>GD</sub>	111	179	214	283	331	407	465	664	938	1093	1286	1333	1453	1710	1792	*	*	*	*	*	*	*	*
20	P <sub>GA</sub>	39.5	50.6	60.9	69.9	82.9	97.1	104	142	172	185	211	200	208	228	230	264	*	*	*	*	*	*	*
	P <sub>GB</sub>	77.4	106	126	158	187	217	235	362	444	497	569	567	608	755	785	*	*	*	*	*	*	*	*
	P <sub>GC</sub>	76.7	118	140	180	212	280	311	430	606	712	814	899	985	1168	1204	*	*	*	*	*	*	*	*
	P <sub>GD</sub>	107	166	197	260	304	390	430	628	856	1002	1145	1228	1349	1654	1708	*	*	*	*	*	*	*	*
22.4	P <sub>GA</sub>	36.5	47.1	58.3	67.5	79.1	89.4	98.6	133	160		214		202		230		267	*	*	*	*	*	*
	P <sub>GB</sub>	71.5	98	121	152	179	201	220	336	414		571		577		765			*	*	*	*	*	*
	P <sub>GC</sub>	69.9	107	133	172	202	252	290	392	567		815		904		1157			*	*	*	*	*	*
	P <sub>GD</sub>	98.3	151	187	247	290	352	401	573	802		1147		1238		1640			*	*	*	*	*	*
25	P <sub>GA</sub>			54.7		74.1		95.8		156		202												
	P <sub>GB</sub>			113		166		213		398		532												
	P <sub>GC</sub>			122		185		278		532		745												
	P <sub>GD</sub>			172		266		384		754		1048												
28	P <sub>GA</sub>			51.2		72		89.9		149														
	P <sub>GB</sub>			105		160		198		371														
	P <sub>GC</sub>			111		177		251		484														
	P <sub>GD</sub>			157		253		350		688														

\* Auf Anfrage

P<sub>GA</sub> (kW) Getriebe ohne Zusatzkühlung \*\*)

P<sub>GB</sub> (kW) Getriebe mit Lüfterkühlung \*\*)

P<sub>GC</sub> (kW) Getriebe mit eingebauter Kühlschlange \*\*) \*\*\*)

P<sub>GD</sub> (kW) Getriebe mit Lüfter und eingebauter Kühlschlange \*\*) \*\*\*)

\*\*\*) Werte gelten für:  
Einschaltdauer: 100 %  
Aufstellung in großer Halle  
Höhenlage bis 1000 m

\*\*\*\*) Werte gelten für eine Kühlwassereintrittstemperatur von 20 °C ohne Begrenzung der Kühlwasseraustrittstemperatur.  
Die Nachrechnung mit Begrenzung der Kühlwasseraustrittstemperatur ist auf Anfrage möglich.

\* On request

P<sub>GA</sub> (kW) Gear units without auxiliary cooling \*\*)

P<sub>GB</sub> (kW) Gear units with fan \*\*)

P<sub>GC</sub> (kW) Gear units with built-in cooling coil \*\*) \*\*\*)

P<sub>GD</sub> (kW) Gear units with fan and built-in cooling coil \*\*) \*\*\*)

\*\*\*) Values refer to:  
Operating cycle: 100 %  
Installation in a large hall  
Altitude up to 1000 m

\*\*\*\*) Values refer to a cooling water inlet temperature of 20 °C with unlimited cooling water outlet temperature.  
A recalculation with a limited cooling water outlet temperature is possible on request.

\* Sur demande

P<sub>GA</sub> (kW) Réducteurs sans refroidissement supplémentaire \*\*\*)

P<sub>GB</sub> (kW) Réducteurs avec ventilateur \*\*)

P<sub>GC</sub> (kW) Réducteurs avec serpentin intégré \*\*) \*\*\*)

P<sub>GD</sub> (kW) Réducteurs avec ventilateur et serpentin intégré \*\*) \*\*\*)

\*\*\*) Les valeurs sont valables pour:  
Durée d'utilisation: 100 %  
Implantation dans un grand hall  
Altitude jusqu'à 1000 m

\*\*\*\*) Les données sont valables pour une température d'eau de refroidissement en entrée de 20 °C sans limitation de la température de l'eau en sortie.  
Un calcul avec limitation de la température d'eau en sortie est possible sur demande.

# Zahnradgetriebe

Wärmegrenzleistungen

Bauart H2..

Größen 4 - 26

$n_1 = 1500 \text{ min}^{-1}$

# Gear Units

Thermal Capacities

Type H2..

Sizes 4 - 26

$n_1 = 1500 \text{ min}^{-1}$

# Réducteurs à engrenages

Capacités thermiques

Type H2..

Tailles 4 - 26

$n_1 = 1500 \text{ min}^{-1}$

Wärmegrenzleistungen  $P_G$  (kW) / Thermal capacities  $P_G$  (kW) / Capacités thermiques  $P_G$  (kW)

$i_N$		Getriebegrößen / Gear unit sizes / Tailles réducteurs																						
		4	5	6	7	8	9	10	11	12	13	14	15	16	17	18	19	20	21	22	23	24	25	26
6.3	$P_{GA}$	48.5	48.8	*	*	*	*	*	*	*	*	*	*	*	*	*	*	*	*	*	*	*	*	*
	$P_{GB}$	132	172		256		322		428		442		*		*		*		*		*		*	
	$P_{GC}$	146	226		357		542		746		1197		1267		1410		*		*		*		*	
	$P_{GD}$	210	327		525		774		1124		1739		1824		2151		*		*		*		*	
7.1	$P_{GA}$	51.6	53.9	*	*	*	*	*	*	*	*	*	*	*	*	*	*	*	*	*	*	*	*	*
	$P_{GB}$	137	177		252		323		453		493		338	*	*	*	*	*	*	*	*	*	*	*
	$P_{GC}$	148	226		338		516		740		1193		1289	1305	1458	1443	*	*	*	*	*	*	*	*
	$P_{GD}$	214	327		499		735		1117		1728		1851	1880	2199	2209	*	*	*	*	*	*	*	*
8	$P_{GA}$	51.4	56.4	59.2	64.9	*	*	*	*	*	*	*	*	*	*	*	*	*	*	*	*	*	*	*
	$P_{GB}$	132	175	191	249	276	322	328	469	501	537	580	422	390	*	*	*	*	*	*	*	*	*	*
	$P_{GC}$	140	219	236	323	367	496	545	720	961	1171	1319	1306	1332	1507	1500	*	*	*	*	*	*	*	*
	$P_{GD}$	202	316	341	479	542	707	772	1088	1397	1700	1923	1860	1910	2261	2260	*	*	*	*	*	*	*	*
9	$P_{GA}$	52.4	60.5	67.8	73.2	77.2	86.3	*	*	*	*	*	*	*	*	*	*	*	*	*	*	*	*	*
	$P_{GB}$	129	174	198	248	275	324	333	484	553	600	666	541	530	584	542	*	*	*	*	*	*	*	*
	$P_{GC}$	135	211	238	311	352	477	521	686	968	1159	1335	1332	1386	1593	1608	*	*	*	*	*	*	*	*
	$P_{GD}$	196	303	344	458	518	682	736	1033	1405	1679	1927	1889	1970	2360	2400	*	*	*	*	*	*	*	*
10	$P_{GA}$	51.4	61.1	70.9	77.7	84.2	96	95.3	*	*	*	*	*	*	*	*	*	*	*	*	*	*	*	*
	$P_{GB}$	123	165	196	241	273	320	335	489	577	631	715	612	617	710	691	*	*	*	*	*	*	*	*
	$P_{GC}$	126	196	230	295	338	453	503	657	943	1128	1309	1316	1383	1611	1649	*	*	*	*	*	*	*	*
	$P_{GD}$	182	282	331	436	498	648	710	987	1375	1628	1896	1861	1964	2374	2447	*	*	*	*	*	*	*	*
11.2	$P_{GA}$	50.4	61.2	72.2	83.4	88	99.9	103	119	*	*	*	*	*	*	*	*	*	*	*	*	*	*	*
	$P_{GB}$	118	160	191	246	267	309	331	509	572	674	738	648	669	784	787	*	*	*	*	*	*	*	*
	$P_{GC}$	120	185	221	294	321	427	479	662	882	1135	1274	1269	1354	1582	1651	*	*	*	*	*	*	*	*
	$P_{GD}$	174	268	319	436	475	610	679	995	1283	1642	1838	1796	1913	2323	2431	*	*	*	*	*	*	*	*
12.5	$P_{GA}$	49.5	62.1	70.5	85.6	88.3	104	106	135	*	*	*	*	*	*	*	*	*	*	*	*	*	*	*
	$P_{GB}$	113	157	181	242	258	305	322	512	562	660	742	685	691	851	840	*	*	*	*	*	*	*	*
	$P_{GC}$	116	183	204	289	305	415	454	655	837	1056	1215	1272	1302	1579	1605	*	*	*	*	*	*	*	*
	$P_{GD}$	166	263	295	425	450	589	644	978	1218	1523	1755	1790	1836	2311	2355	*	*	*	*	*	*	*	*
14	$P_{GA}$	47.6	60.4	69.5	81.7	93.2	106	108	142	153	*	*	*	*	*	*	*	*	*	*	*	*	*	*
	$P_{GB}$	108	150	174	224	263	298	310	494	583	647	774	686	726	875	906	*	*	*	*	*	*	*	*
	$P_{GC}$	108	171	193	259	304	393	425	611	841	991	1220	1205	1298	1511	1600	*	*	*	*	*	*	*	*
	$P_{GD}$	155	243	279	384	449	562	603	914	1223	1434	1761	1697	1832	2211	2342	*	*	*	*	*	*	*	*
16	$P_{GA}$	44.1	57.8	69.8	78.6	94.9	104	110	144	169	160	193	*	*	*	*	*	*	*	*	*	*	*	*
	$P_{GB}$	98.9	140	169	210	257	281	303	469	583	603	751	710	721	873	919	*	*	*	*	*	*	*	*
	$P_{GC}$	98.1	157	191	239	297	362	414	561	827	887	1125	1196	1226	1429	1528	*	*	*	*	*	*	*	*
	$P_{GD}$	141	225	273	352	438	518	584	839	1197	1286	1626	1684	1726	2088	2236	*	*	*	*	*	*	*	*
18	$P_{GA}$	42.7	56.4	67.6	77.3	89.8	101	111	143	175	181	209	170	*	*	*	*	*	*	*	*	*	*	*
	$P_{GB}$	94.4	134	162	202	237	266	296	443	560	621	731	690	748	888	919	*	*	*	*	*	*	*	*
	$P_{GC}$	92.4	148	177	229	268	339	392	527	769	899	1057	1119	1219	1387	1442	*	*	*	*	*	*	*	*
	$P_{GD}$	132	213	255	338	395	486	555	790	1115	1297	1526	1578	1718	2020	2114	*	*	*	*	*	*	*	*
20	$P_{GA}$	42	53.3	64	73.1	86.3	100	107	142	170	179	202	179	182	*	*	*	*	*	*	*	*	*	*
	$P_{GB}$	92.1	126	150	188	222	257	278	428	525	586	670	665	712	882	915	*	*	*	*	*	*	*	*
	$P_{GC}$	89.4	138	162	209	247	326	362	499	702	823	941	1036	1133	1342	1382	*	*	*	*	*	*	*	*
	$P_{GD}$	128	198	235	310	363	465	512	747	1019	1191	1360	1455	1597	1956	2019	*	*	*	*	*	*	*	*
22.4	$P_{GA}$	38.9	49.7	61.3	70.7	82.4	92.6	101	133	159		206		179	*	*	*	*	*	*	*	*	*	*
	$P_{GB}$	85.2	116	144	181	213	239	261	397	489		673		676		893	*	*	*	*	*	*	*	*
	$P_{GC}$	81.5	125	155	200	235	293	337	454	657		942		1041		1329	*	*	*	*	*	*	*	*
	$P_{GD}$	117	181	223	295	346	420	478	682	954		1362		1467		1939	*	*	*	*	*	*	*	*
25	$P_{GA}$			57.6		77.2		98.9		155		195												
	$P_{GB}$			134		197		252		470		627												
	$P_{GC}$			142		216		323		617		862												
	$P_{GD}$			206		318		458		898		1245												
28	$P_{GA}$			54.1		75.5		93.4		150														
	$P_{GB}$			125		190		235		439														
	$P_{GC}$			130		206		292		562														
	$P_{GD}$			187		302		417		819														

\* Auf Anfrage

$P_{GA}$  (kW) Getriebe ohne Zusatzkühlung \*\*)

$P_{GB}$  (kW) Getriebe mit Lüfterkühlung \*\*)

$P_{GC}$  (kW) Getriebe mit eingebauter Kühlschlange \*\*) \*\*\*)

$P_{GD}$  (kW) Getriebe mit Lüfter und eingebauter Kühlschlange \*\*) \*\*\*)

\*\*) Werte gelten für:  
Einschaltdauer: 100 %  
Aufstellung in großer Halle  
Höhenlage bis 1000 m

\*\*\*) Werte gelten für eine Kühlwassereintrittstemperatur von 20 °C ohne Begrenzung der Kühlwasseraustrittstemperatur.  
Die Nachrechnung mit Begrenzung der Kühlwasseraustrittstemperatur ist auf Anfrage möglich.

\* On request

$P_{GA}$  (kW) Gear units without auxiliary cooling \*\*)

$P_{GB}$  (kW) Gear units with fan \*\*)

$P_{GC}$  (kW) Gear units with built-in cooling coil \*\*) \*\*\*)

$P_{GD}$  (kW) Gear units with fan and built-in cooling coil \*\*) \*\*\*)

\*\*) Values refer to:  
Operating cycle: 100 %  
Installation in a large hall  
Altitude up to 1000 m

\*\*\*) Values refer to a cooling water inlet temperature of 20 °C with unlimited cooling water outlet temperature.  
A recalculation with a limited cooling water outlet temperature is possible on request.

\* Sur demande

$P_{GA}$  (kW) Réducteurs sans refroidissement supplémentaire \*\*)

$P_{GB}$  (kW) Réducteurs avec ventilateur \*\*)

$P_{GC}$  (kW) Réducteurs avec serpentin intégré \*\*) \*\*\*)

$P_{GD}$  (kW) Réducteurs avec ventilateur et serpentin intégré \*\*) \*\*\*)

\*\*) Les valeurs sont valables pour:  
Durée d'utilisation: 100 %  
Implantation dans un grand hall  
Altitude jusqu'à 1000 m

\*\*\*) Les données sont valables pour une température d'eau de refroidissement en entrée de 20 °C sans limitation de la température de l'eau en sortie.  
Un calcul avec limitation de la température d'eau en sortie est possible sur demande.

# Zahnradgetriebe

Wärmegrenzleistungen

Bauart H2..

Größen 4 - 26

**n<sub>1</sub> = 1800 min<sup>-1</sup>**

# Gear Units

Thermal Capacities

Type H2..

Sizes 4 - 26

**n<sub>1</sub> = 1800 min<sup>-1</sup>**

# Réducteurs à engrenages

Capacités thermiques

Type H2..

Tailles 4 - 26

**n<sub>1</sub> = 1800 min<sup>-1</sup>**

Wärmegrenzleistungen P <sub>G</sub> (kW) / Thermal capacities P <sub>G</sub> (kW) / Capacités thermiques P <sub>G</sub> (kW)																								
i <sub>N</sub>		Getriebegrößen / Gear unit sizes / Tailles réducteurs																						
		4	5	6	7	8	9	10	11	12	13	14	15	16	17	18	19	20	21	22	23	24	25	26
6.3	P <sub>GA</sub>	40.6	*		*		*		*		*		*		*		*		*		*		*	
	P <sub>GB</sub>	144	181		263		319		366		*		*		*		*		*		*		*	
	P <sub>GC</sub>	157	239		373		558		732		1102		1027		1020		*		*		*		*	
	P <sub>GD</sub>	236	361		574		832		1154		1678		1562		1661		*		*		*		*	
7.1	P <sub>GA</sub>	44.6	*		*		*		*		*		*		*		*		*		*		*	
	P <sub>GB</sub>	150	189		262		325		408		357		*		*		*		*		*		*	
	P <sub>GC</sub>	159	241		355		536		738		1127		1102	1081	1147	1080	*	*	*	*	*	*	*	*
	P <sub>GD</sub>	240	363		548		797		1163		1710		1666	1644	1832	1759	*	*	*	*	*	*	*	*
8	P <sub>GA</sub>	45.7	*	*	*	*	*	*	*	*	*	*	*	*	*	*	*	*	*	*	*	*	*	*
	P <sub>GB</sub>	145	188	204	262	287	330	332	441	444	436	453	*	*	*	*	*	*	*	*	*	*	*	*
	P <sub>GC</sub>	152	234	251	342	386	519	567	728	954	1134	1266	1169	1165	1269	1219	*	*	*	*	*	*	*	*
	P <sub>GD</sub>	228	352	379	529	595	772	837	1149	1449	1722	1931	1749	1757	2006	1941	*	*	*	*	*	*	*	*
9	P <sub>GA</sub>	48.3	50.5	54.7	*	*	*	*	*	*	*	*	*	*	*	*	*	*	*	*	*	*	*	*
	P <sub>GB</sub>	143	189	214	266	293	341	347	481	530	547	595	402	363	*	*	*	*	*	*	*	*	*	*
	P <sub>GC</sub>	146	227	256	332	374	505	548	707	985	1160	1327	1265	1296	1455	1438	*	*	*	*	*	*	*	*
	P <sub>GD</sub>	221	340	384	510	574	753	809	1113	1494	1755	2003	1877	1930	2262	2254	*	*	*	*	*	*	*	*
10	P <sub>GA</sub>	48.5	53.7	61	63.7	65.2	*	*	*	*	*	*	*	*	*	*	*	*	*	*	*	*	*	*
	P <sub>GB</sub>	136	181	214	261	294	342	355	501	577	611	683	526	510	547	495	*	*	*	*	*	*	*	*
	P <sub>GC</sub>	137	211	248	317	361	483	534	687	975	1152	1331	1294	1345	1541	1555	*	*	*	*	*	*	*	*
	P <sub>GD</sub>	207	318	372	489	555	720	787	1077	1485	1736	2013	1913	1999	2378	2418	*	*	*	*	*	*	*	*
11.2	P <sub>GA</sub>	48.3	55.6	64.6	72.1	73.2	79.4	*	*	*	*	*	*	*	*	*	*	*	*	*	*	*	*	*
	P <sub>GB</sub>	132	177	210	269	290	333	355	533	587	675	733	600	604	679	655	*	*	*	*	*	*	*	*
	P <sub>GC</sub>	130	200	239	317	345	457	512	698	923	1175	1314	1276	1350	1558	1609	*	*	*	*	*	*	*	*
	P <sub>GD</sub>	197	303	359	490	533	682	756	1095	1401	1775	1980	1886	1994	2393	2478	*	*	*	*	*	*	*	*
12.5	P <sub>GA</sub>	47.9	57.7	64.6	76.5	76.6	87.5	86.5	*	*	*	*	*	*	*	*	*	*	*	*	*	*	*	*
	P <sub>GB</sub>	127	174	200	266	282	332	348	543	587	677	756	662	656	786	754	*	*	*	*	*	*	*	*
	P <sub>GC</sub>	126	199	221	313	329	447	487	695	883	1105	1267	1298	1321	1585	1598	*	*	*	*	*	*	*	*
	P <sub>GD</sub>	189	297	333	480	506	661	720	1083	1340	1662	1910	1908	1945	2426	2451	*	*	*	*	*	*	*	*
14	P <sub>GA</sub>	46.5	57	65	75	83.7	93.7	92.7	*	*	*	*	*	*	*	*	*	*	*	*	*	*	*	*
	P <sub>GB</sub>	120	166	193	247	289	326	338	530	618	676	805	686	717	846	861	*	*	*	*	*	*	*	*
	P <sub>GC</sub>	118	186	209	281	329	424	458	653	892	1045	1284	1246	1336	1543	1623	*	*	*	*	*	*	*	*
	P <sub>GD</sub>	177	276	316	434	507	632	677	1018	1355	1578	1933	1832	1969	2358	2482	*	*	*	*	*	*	*	*
16	P <sub>GA</sub>	43.5	55.4	66.4	73.6	87.3	94.2	98	116	*	*	*	*	*	*	*	*	*	*	*	*	*	*	*
	P <sub>GB</sub>	110	155	188	232	283	309	333	507	625	639	792	727	731	872	905	*	*	*	*	*	*	*	*
	P <sub>GC</sub>	107	171	207	260	322	392	448	602	882	941	1192	1249	1275	1477	1571	*	*	*	*	*	*	*	*
	P <sub>GD</sub>	160	256	310	399	496	584	658	939	1333	1424	1797	1836	1875	2253	2401	*	*	*	*	*	*	*	*
18	P <sub>GA</sub>	42.3	54.7	65.2	73.7	84.5	94.5	102	122	142	*	*	*	*	*	*	*	*	*	*	*	*	*	*
	P <sub>GB</sub>	105	150	180	225	263	295	326	483	606	667	782	722	777	912	934	*	*	*	*	*	*	*	*
	P <sub>GC</sub>	101	161	192	249	292	368	424	567	825	960	1127	1180	1282	1451	1503	*	*	*	*	*	*	*	*
	P <sub>GD</sub>	151	242	290	383	447	550	627	887	1249	1446	1698	1736	1885	2206	2299	*	*	*	*	*	*	*	*
20	P <sub>GA</sub>	41.8	52.1	62.2	70.2	82	94.4	99.9	125	144	142	157	*	*	*	*	*	*	*	*	*	*	*	*
	P <sub>GB</sub>	103	140	168	210	246	285	308	469	571	633	722	702	748	918	944	*	*	*	*	*	*	*	*
	P <sub>GC</sub>	97.8	150	177	228	268	354	392	539	755	882	1007	1098	1197	1412	1449	*	*	*	*	*	*	*	*
	P <sub>GD</sub>	146	225	268	352	411	527	580	842	1143	1331	1519	1609	1761	2148	2209	*	*	*	*	*	*	*	*
22.4	P <sub>GA</sub>	38.7	48.6	59.6	68	78.5	87.3	94.7	118	135		162												
	P <sub>GB</sub>	95.6	130	161	202	237	265	289	436	533		726		712		924	*	*	*	*	*	*	*	*
	P <sub>GC</sub>	89.1	136	169	218	256	319	366	491	708		1009		1101		1395	*	*	*	*	*	*	*	*
	P <sub>GD</sub>	133	205	253	335	392	476	541	768	1071		1522		1619		2125	*	*	*	*	*	*	*	*
25	P <sub>GA</sub>			56.1		73.8		92.5		133		156												
	P <sub>GB</sub>			150		219		280		513		678												
	P <sub>GC</sub>			154		235		351		665		924												
	P <sub>GD</sub>			234		360		519		1009		1392												
28	P <sub>GA</sub>			53		72.8		88.5		133														
	P <sub>GB</sub>			139		212		261		482														
	P <sub>GC</sub>			142		224		318		606														
	P <sub>GD</sub>			213		344		473		923														

\* Auf Anfrage

P<sub>GA</sub> (kW) Getriebe ohne Zusatzkühlung \*\*)

P<sub>GB</sub> (kW) Getriebe mit Lüfterkühlung \*\*)

P<sub>GC</sub> (kW) Getriebe mit eingebauter Kühlschlange \*\*) \*\*\*)

P<sub>GD</sub> (kW) Getriebe mit Lüfter und eingebauter Kühlschlange \*\*) \*\*\*)

\*\*\*) Werte gelten für:  
Einschaltdauer: 100 %  
Aufstellung in großer Halle  
Höhenlage bis 1000 m

\*\*\*\*) Werte gelten für eine Kühlwassertemperatur von 20 °C ohne Begrenzung der Kühlwasseraustrittstemperatur.  
Die Nachrechnung mit Begrenzung der Kühlwasseraustrittstemperatur ist auf Anfrage möglich.

\* On request

P<sub>GA</sub> (kW) Gear units without auxiliary cooling \*\*)

P<sub>GB</sub> (kW) Gear units with fan \*\*)

P<sub>GC</sub> (kW) Gear units with built-in cooling coil \*\*) \*\*\*)

P<sub>GD</sub> (kW) Gear units with fan and built-in cooling coil \*\*) \*\*\*)

\*\*\*) Values refer to:  
Operating cycle: 100 %  
Installation in a large hall  
Altitude up to 1000 m

\*\*\*\*) Values refer to a cooling water inlet temperature of 20 °C with unlimited cooling water outlet temperature.  
A recalculation with a limited cooling water outlet temperature is possible on request.

\* Sur demande

P<sub>GA</sub> (kW) Réducteurs sans refroidissement supplémentaire \*\*)

P<sub>GB</sub> (kW) Réducteurs avec ventilateur \*\*)

P<sub>GC</sub> (kW) Réducteurs avec serpentin intégré \*\*) \*\*\*)

P<sub>GD</sub> (kW) Réducteurs avec ventilateur et serpentin intégré \*\*) \*\*\*)

\*\*\*) Les valeurs sont valables pour:  
Durée d'utilisation: 100 %  
Implantation dans un grand hall  
Altitude jusqu'à 1000 m

\*\*\*\*) Les données sont valables pour une température d'eau de refroidissement en entrée de 20 °C sans limitation de la température de l'eau en sortie.  
Un calcul avec limitation de la température d'eau en sortie est possible sur demande.





# Zahnradgetriebe

Nenn-Abtriebsdrehmomente  
Bauart H3..  
Größen 5 - 26

# Gear Units

Nominal Output Torques  
Type H3..  
Sizes 5 - 26

# Réducteurs à engrenages

Couples nominaux de sortie  
Type H3..  
Tailles 5 - 26

Nenn-Abtriebsdrehmomente T <sub>2N</sub> (kNm) Nominal output torques T <sub>2N</sub> (kNm) / Couples nominaux de sortie T <sub>2N</sub> (kNm)																									
i <sub>N</sub>	Getriebegrößen / Gear unit sizes / Tailles réducteurs																								
	3	4	5	6	7	8	9	10	11	12	13	14	15	16	17	18	19	20	21	22	23	24	25	26	
1.25	2.9		8		15.2		24.7																		
1.4	3.1		8.2		15.9		25.6																		
1.6	3.3		8.6		16.3		27.1		46		67.4														
1.8	2.7		8.8		17.4		28		47.6		70.9														
2	2.8		9.4		17.8		28.7		49.1		72.9		129												
2.24	2.8		9.6		17.8		28.7		50.6		75.2		130												
2.5	2.9		9.6		17.8		28.7		50.6		77														
2.8	3.1		9.6		17.1		27.9		50.6		77														
3.15	3.1		9.6		17.4		28.7		48.1		73.1														
3.55	3.2		9.5		17.8		28.6		50.2		74.4														
4	3.2		9.6		17.8		28.7		50.6		75.7		130		173		245								
4.5	2.5		7.7		15.8		24.6		46		61.6		109		146		216								
5	2.4		7.2		13.8		23.5		38.7		58.3		95		124		174								
5.6	2.3		6.9		13.1		20.1		36.5		55.4		90.4		118		150								
6.3		6.3	10.7		20.3		33.7		59.3		86		143		195		292								
7.1		6.5	11.2		20.3		33.7		59.3		86		143	160	195	230	292	335	410						
8		6.7	11.2	13.5	20.3	25.6	33.7	42.2	59.3	73.8	86	107	143	160	195	230	292	335	410	458					
9		6.7	11.2	14.4	20.3	25.6	33.7	42.2	59.3	73.8	86	107	143	160	195	230	292	335	410	458	540				
10		6.3	10.5	14.4	20.3	25.6	33.7	42.2	59.3	73.8	86	107	143	160	195	230	292	335	410	458	540	620			
11.2		6.3	10.6	14.4	20.3	25.6	33.7	42.2	59.3	73.8	86	107	143	160	195	230	292	335	410	458	540	620	780		
12.5		6.7	11.2	13.5	20.2	25.6	33.7	42.2	59.3	73.8	86	107	143	160	195	230	292	335	410	458	540	620	780	880	
14		6.7	11.2	13.5	20.3	25.6	33.7	42.2	59.3	73.8	86	107	143	160	195	230	292	335	410	458	540	620	780	880	
16		6.7	11.2	14.4	20.3	25.5	33.7	42.2	59.3	73.8	86	107	143	160	195	230	292	335	410	458	540	620	780	880	
18		6.3	10.5	14.4	19	25.6	33.7	42.2	59.3	73.8	86	107	143	160	195	230	292	335	410	458	540	620	780	880	
20		6.6	11.2	14.4	19	25.6	33.7	42.2	59.3	73.8	86	107	143	160	195	230	292	335	410	458	540	620	780	880	
22.4		6.3	10.9	13.5	19.8	24	33.1	42.2	58.3	73.8	88	107	153	160	200	230	300	335	420	458	560	620	800	880	
25			11.6	14.3	21.7	24	35.7	42.2	63.5	73.8	88	107	153	173	200	240	300	345	420	470	560	640	800	900	
28			11.6	13.9	21.7	25	35.7	41.6	63.5	72.5	88	109	153	173	200	240	300	345	420	470	560	640	800	900	
31.5			11.6	15.5	21.7	27.2	35.7	43.8	63.5	77.2	88	109	153	173	200	240	300	345	420	470	560	640	800	900	
35.5			11.6	15.5	21.7	27.2	35.7	43.8	63.5	77.2	88	109	153	173	200	240	300	345	420	470	560	640	800	900	
40			11.6	15.5	21.7	27.2	35.7	43.8	63.5	77.2	88	109	153	173	200	240	300	345	420	470	560	640	800	900	
45			11.6	15.5	21.7	27.2	35.7	43.8	63.5	77.2	88	109	153	173	200	240	300	345	420	470	560	640	800	900	
50			11.6	15.5	21.7	27.2	35.7	43.8	63.5	77.2	88	109	153	173	200	240	300	345	420	470	560	640	800	900	
56			11.6	15.5	21.7	27.2	35.7	43.8	63.5	77.2	88	109	153	173	200	240	300	345	420	470	560	640	800	900	
63			11.6	15.5	21.7	27.2	35.7	43.8	63.5	77.2	88	109	153	173	200	240	300	345	420	470	560	640	800	900	
71			11.6	15.5	21.7	27.2	35.7	43.8	63.5	77.2	88	109	153	173	200	240	300	345	420	470	560	640	800	900	
80			11.6	15.5	21.7	27.2	35.7	43.8	63.5	77.2	88	109	153	173	200	240	300	345	420	470	560	640	800	900	
90			11.6	15.5	20	27.2	34.5	43.8	63.5	77.2	88	109	153	173	200	240	290	345	410	470	560	640	800	900	
100				14.5	21.7	27.2	35.7	43.8	61.6	77.2	90.7	109	153	173	200	226	300	335	420	465	560	640	800	900	
112				15	21.7	25.2	35.7	42.8	61.6	77.2	90.7	109	153	173	200	240	300	345	420	470	560	640	800	900	
125					21.7	27.2	35.7	44.2	61.6	78	90.7	113	153	173	200	240	300	345	420	470	560	640	800	900	
140					21.7	27.2	35.7	44.2	61.6	78	90.7	113	153	173	200	240	300	345	420	470	560	640	800	900	
160					21.7	27.2	35.7	44.2	61.6	78	90.7	113	153	173	200	240	300	345	420	470	560	640	800	900	
180					21.7	27.2	35.7	44.2	61.6	78	90.7	113	153	173	200	240	300	345	420	470	560	640	800	900	
200					21.7	27.2	35.7	44.2	61.6	78	90.7	113	153	173	200	240	300	345	420	470	560	640	800	900	
224					21.7	27.2	35.7	44.2	61.6	78	90.7	113	153	173	200	240	300	345	420	470	560	640	800	900	
250					21.7	27.2	35.7	44.2	61.6	78	90.7	113	153	173	200	240	300	345	420	470	560	640	800	900	
280					21.7	27.2	35.7	44.2	61.6	78	90.7	113	153	173	200	240	300	345	420	470	560	640	800	900	
315					21.7	27.2	35.7	44.2	61.6	78	90.7	113	153	173	200	240	300	345	420	470	560	640	800	900	
355					19.6	27.2	35.7	44.2	61.6	78	90.7	113	140	173	192	240	290	345	410	470	560	640	800	900	
400						27.2		44.2		78		113		158		223		335		465		640		900	
450						25.3		42.8		78		113													



# Zahnradgetriebe

Wärmegrenzleistungen

Bauart H3..

Größen 5 - 26

$n_1 = 1200 \text{ min}^{-1}$

# Gear Units

Thermal Capacities

Type H3..

Sizes 5 - 26

$n_1 = 1200 \text{ min}^{-1}$

# Réducteurs à engrenages

Capacités thermiques

Type H3..

Tailles 5 - 26

$n_1 = 1200 \text{ min}^{-1}$

Wärmegrenzleistungen P <sub>G</sub> (kW) / Thermal capacities P <sub>G</sub> (kW) / Capacités thermiques P <sub>G</sub> (kW)																							
i <sub>N</sub>		Getriebegrößen / Gear unit sizes / Tailles réducteurs																					
		5	6	7	8	9	10	11	12	13	14	15	16	17	18	19	20	21	22	23	24	25	26
22.4	P <sub>GA</sub>									173		209		206		232	*	*	*	*	*	*	*
	P <sub>GB</sub>									295		393		382		*	*	*	*	*	*	*	*
	P <sub>GC</sub>									580		913		901		*	*	*	*	*	*	*	*
	P <sub>GD</sub>									681		1059		1023		*	*	*	*	*	*	*	*
25	P <sub>GA</sub>	49.8		72.6		96.6		136		170		207	212	203	207	234	235	*	*	*	*	*	*
	P <sub>GB</sub>	79.1		118		160		235		288		385	399	375	386	*	*	*	*	*	*	*	*
	P <sub>GC</sub>	113		180		262		439		552		862	921	852	900	*	*	*	*	*	*	*	*
	P <sub>GD</sub>	138		221		319		527		647		1004	1066	970	1021	*	*	*	*	*	*	*	*
28	P <sub>GA</sub>	48.1		73.7		97.1		134		170	193	216	221	215	217	252	255	*	*	*	*	*	*
	P <sub>GB</sub>	76.5		120		159		229		285	324	394	404	387	394	*	*	*	*	*	*	*	*
	P <sub>GC</sub>	106		179		255		419		521	609	839	875	828	859	*	*	*	*	*	*	*	*
	P <sub>GD</sub>	131		221		311		500		617	718	987	1024	956	987	*	*	*	*	*	*	*	*
31.5	P <sub>GA</sub>	47.1	54.2	71.3	78.6	95.8	98.4	132	156	171	194	222	230	223	230	267	274	276	*	*	*	*	*
	P <sub>GB</sub>	74.4	85.3	115	127	157	161	225	263	283	322	399	415	394	408	*	*	*	*	*	*	*	*
	P <sub>GC</sub>	102	117	169	185	245	305	396	454	503	581	808	852	802	840	*	*	*	*	*	*	*	*
	P <sub>GD</sub>	126	144	210	227	300	365	481	549	598	690	959	1008	935	975	*	*	*	*	*	*	*	*
35.5	P <sub>GA</sub>	45.7	52.5	69.7	79.8	93.6	99	130	153	171	194	222	237	226	239	279	290	311	292	*	*	*	*
	P <sub>GB</sub>	72.2	82.4	113	128	153	160	220	257	280	320	393	420	391	417	*	*	*	*	*	*	*	*
	P <sub>GC</sub>	98.3	110	163	183	234	297	376	427	481	550	755	822	749	812	*	*	*	*	*	*	*	*
	P <sub>GD</sub>	121	137	202	227	289	356	460	521	576	658	905	984	884	954	*	*	*	*	*	*	*	*
40	P <sub>GA</sub>	43.3	51.1	66.5	76.9	88.9	96.2	126	150	167	192	219	231	223	235	279	293	322	310	*	*	*	*
	P <sub>GB</sub>	68.1	80	107	123	145	156	212	251	272	313	383	406	383	404	*	*	*	*	*	*	*	*
	P <sub>GC</sub>	91.3	106	151	173	219	284	355	407	455	527	714	765	712	756	*	*	*	*	*	*	*	*
	P <sub>GD</sub>	112	131	189	215	270	342	434	497	547	633	862	921	843	895	*	*	*	*	*	*	*	*
45	P <sub>GA</sub>	41.5	49.4	64.2	74.7	85.9	93.9	126	145	161	186	220	226	224	229	281	287	321	313	*	*	*	*
	P <sub>GB</sub>	65.2	77.3	103	120	139	152	212	242	261	303	384	393	382	392	*	*	*	*	*	*	*	*
	P <sub>GC</sub>	86.3	101	144	166	207	272	347	387	429	502	701	724	698	715	*	*	*	*	*	*	*	*
	P <sub>GD</sub>	106	125	180	206	256	329	427	474	516	603	847	871	828	848	*	*	*	*	*	*	*	*
50	P <sub>GA</sub>	40.4	47	61.2	71.9	85.2	90.3	127	144	164	187	232	239	236	245	300	309	365	356	*	*	*	*
	P <sub>GB</sub>	63.2	73.2	98.2	114	137	145	210	238	262	301	395	410	394	410	*	*	*	*	*	*	*	*
	P <sub>GC</sub>	83.5	94.6	136	156	203	254	342	368	421	477	701	717	691	707	*	*	*	*	*	*	*	*
	P <sub>GD</sub>	103	117	169	193	250	307	421	452	510	580	852	872	832	853	*	*	*	*	*	*	*	*
56	P <sub>GA</sub>	38.5	45.3	58.7	69.7	81.8	87.7	119	146	161	183	228	245	234	250	300	319	374	386	*	*	*	*
	P <sub>GB</sub>	60.1	70.4	93.7	110	131	140	197	240	257	292	384	414	387	414	*	*	*	*	*	*	*	*
	P <sub>GC</sub>	78.5	89.7	128	148	190	241	311	361	400	451	658	713	652	700	*	*	*	*	*	*	*	*
	P <sub>GD</sub>	96.9	111	160	185	236	292	383	446	486	550	805	869	789	846	*	*	*	*	*	*	*	*
63	P <sub>GA</sub>	36.4	43.9	55.1	66.4	78	86.5	115	145	156	182	222	242	229	249	293	320	382	398	*	*	*	*
	P <sub>GB</sub>	56.6	67.9	87.6	105	124	137	188	236	247	289	371	405	375	406	*	*	*	*	*	*	*	*
	P <sub>GC</sub>	72.8	86.6	118	139	176	235	289	356	374	441	611	667	607	659	*	*	*	*	*	*	*	*
	P <sub>GD</sub>	90.2	107	146	174	220	286	357	439	456	540	753	824	741	804	*	*	*	*	*	*	*	*
71	P <sub>GA</sub>	36.1	41.6	53.5	63.2	76.4	82.4	112	135	152	177	217	230	222	236	290	301	365	385	*	*	*	*
	P <sub>GB</sub>	56	64.3	84.8	99.8	122	131	182	219	239	279	361	382	361	385	*	*	*	*	*	*	*	*
	P <sub>GC</sub>	72	81.2	113	130	173	220	279	321	357	419	589	620	581	611	*	*	*	*	*	*	*	*
	P <sub>GD</sub>	89.2	100	141	163	214	267	345	398	436	512	725	764	712	746	*	*	*	*	*	*	*	*
80	P <sub>GA</sub>	34.3	39.2	52.3	59.1	72.4	78	106	128	148	167	210	224	214	228	277	299	352	368	*	*	*	*
	P <sub>GB</sub>	53	60.3	82.8	92.9	114	123	172	207	233	264	348	371	348	371	*	*	*	*	*	*	*	*
	P <sub>GC</sub>	66.9	75.5	109	120	160	204	257	298	344	389	556	596	550	586	*	*	*	*	*	*	*	*
	P <sub>GD</sub>	83	93.6	136	150	200	248	319	370	420	478	688	735	673	716	*	*	*	*	*	*	*	*
90	P <sub>GA</sub>	33.9	38.9	49.5	57.2	68.8	76.2	103	125	138	163	199	217	203	220	264	284	345	355	*	*	*	*
	P <sub>GB</sub>	52.4	59.8	78.3	89.7	109	119	166	201	218	256	328	358	329	357	*	*	*	*	*	*	*	*
	P <sub>GC</sub>	65.1	74.8	100	115	149	200	247	288	316	372	515	563	509	555	*	*	*	*	*	*	*	*
	P <sub>GD</sub>	81	92.7	126	145	186	242	307	358	388	455	637	697	625	680	*	*	*	*	*	*	*	*
100	P <sub>GA</sub>		37		56.3		72.7		119		160		207		212		276		358	*	*	*	*
	P <sub>GB</sub>		56.8		88.1		114		191		251		340		340		*		*	*	*	*	*
	P <sub>GC</sub>		69.5		112		186		267		359		523		515		*		*	*	*	*	*
	P <sub>GD</sub>		86.5		140		226		332		441		648		634		*		*	*	*	*	*
112	P <sub>GA</sub>		36.6		53.3		69.2		116		150									*	*	*	*
	P <sub>GB</sub>		56.2		83.4		108		185		235									*	*	*	*
	P <sub>GC</sub>		67.8		103		172		257		330									*	*	*	*
	P <sub>GD</sub>		84.3		130		211		320		407									*	*	*	*

\* Auf Anfrage

P<sub>GA</sub> (kW) Getriebe ohne Zusatzkühlung \*\*)

P<sub>GB</sub> (kW) Getriebe mit Lüfterkühlung \*\*)

P<sub>GC</sub> (kW) Getriebe mit eingebauter Kühltorschlange \*\*\*)

P<sub>GD</sub> (kW) Getriebe mit Lüfter und eingebauter Kühltorschlange \*\*\*)

\*\* Werte gelten für:

Einschaltdauer: 100 %, Aufstellung in großer Halle, Höhenlage bis 1000 m

\*\*\*) Werte gelten für eine Kühlwassereintrittstemperatur von 20 °C ohne Begrenzung der Kühlwasseraustrittstemperatur.

Die Nachrechnung mit Begrenzung der Kühlwasseraustrittstemperatur ist auf Anfrage möglich.

\* On request

P<sub>GA</sub> (kW) Gear units without auxiliary cooling \*\*)

P<sub>GB</sub> (kW) Gear units with fan \*\*)

P<sub>GC</sub> (kW) Gear units with built-in cooling coil \*\*\*)

P<sub>GD</sub> (kW) Gear units with fan and built-in cooling coil \*\*\*)

\*\* Values refer to:

Operating cycle: 100 %, Installation in a large hall, Altitude up to 1000 m

\*\*\*) Values refer to a cooling water inlet temperature of 20 °C with unlimited cooling water outlet temperature.

A recalculation with a limited cooling water outlet temperature is possible on request.

\* Sur demande

P<sub>GA</sub> (kW) Réducteurs sans refroidissement supplémentaire \*\*)

P<sub>GB</sub> (kW) Réducteurs avec ventilateur \*\*)

P<sub>GC</sub> (kW) Réducteurs avec serpentin intégré \*\*\*)

P<sub>GD</sub> (kW) Réducteurs avec ventilateur et serpentin intégré \*\*\*)

\*\* Les valeurs sont valables pour:

Durée d'utilisation: 100 %, Implantation dans un grand hall, Altitude jusqu'à 1000 m

\*\*\*) Les données sont valables pour une température d'eau de refroidissement en entrée de 20 °C sans limitation de la température de l'eau en sortie.

Un calcul avec limitation de la température d'eau en sortie est possible sur demande.

# Zahnradgetriebe

Wärmegrenzleistungen

Bauart H3..

Größen 5 - 26

$n_1 = 1500 \text{ min}^{-1}$

# Gear Units

Thermal Capacities

Type H3..

Sizes 5 - 26

$n_1 = 1500 \text{ min}^{-1}$

# Réducteurs à engrenages

Capacités thermiques

Type H3..

Tailles 5 - 26

$n_1 = 1500 \text{ min}^{-1}$

Wärmegrenzleistungen  $P_G$  (kW) / Thermal capacities  $P_G$  (kW) / Capacités thermiques  $P_G$  (kW)

$i_N$		Getriebegrößen / Gear unit sizes / Tailles réducteurs																					
		5	6	7	8	9	10	11	12	13	14	15	16	17	18	19	20	21	22	23	24	25	26
22.4	$P_{GA}$									169		193		180		*		*		*		*	
	$P_{GB}$									346		463		450		*		*		*		*	
	$P_{GC}$									668		1050		1035		*		*		*		*	
	$P_{GD}$									811		1267		1228		*		*		*		*	
25	$P_{GA}$	52.5		76.1		100		138		167		192	193	180	*	*	*	*	*	*	*	*	*
	$P_{GB}$	92.4		138		187		275		338		453	470	442	455	*	*	*	*	*	*	*	*
	$P_{GC}$	130		208		302		507		636		992	1059	979	1035	*	*	*	*	*	*	*	*
	$P_{GD}$	163		261		378		626		771		1201	1277	1164	1227	*	*	*	*	*	*	*	*
28	$P_{GA}$	50.9		77.5		101		137		169	191	206	207	198	196	222	*	*	*	*	*	*	*
	$P_{GB}$	89.4		140		186		268		334	380	463	475	455	464	*	*	*	*	*	*	*	*
	$P_{GC}$	123		207		294		477		600	701	966	1008	953	988	*	*	*	*	*	*	*	*
	$P_{GD}$	155		261		368		593		734	854	1179	1224	1145	1182	*	*	*	*	*	*	*	*
31.5	$P_{GA}$	49.9	57.4	75.3	82.8	100	102	137	159	173	196	217	222	212	216	246	249	*	*	*	*	*	*
	$P_{GB}$	86.9	99.6	135	148	183	188	263	308	332	377	468	487	463	480	*	*	*	*	*	*	*	*
	$P_{GC}$	118	135	195	214	283	352	457	523	580	670	930	981	924	967	*	*	*	*	*	*	*	*
	$P_{GD}$	149	170	248	268	355	432	570	650	710	819	1143	1202	1116	1165	*	*	*	*	*	*	*	*
35.5	$P_{GA}$	48.6	55.7	73.9	84.4	98.7	104	135	158	175	198	222	235	221	232	268	276	273	*	*	*	*	*
	$P_{GB}$	84.3	96.2	132	150	178	186	257	300	328	374	461	493	459	489	*	*	*	*	*	*	*	*
	$P_{GC}$	113	127	188	211	271	343	434	492	555	634	870	948	863	935	*	*	*	*	*	*	*	*
	$P_{GD}$	143	161	239	268	342	421	544	617	683	781	1075	1171	1052	1137	*	*	*	*	*	*	*	*
40	$P_{GA}$	46.1	54.3	70.6	81.4	93.9	101	132	156	172	197	221	232	221	231	272	283	293	269	*	*	*	*
	$P_{GB}$	79.5	93.4	125	144	170	182	248	293	318	366	449	476	449	474	*	*	*	*	*	*	*	*
	$P_{GC}$	105	122	175	200	252	327	410	470	525	608	823	882	820	871	*	*	*	*	*	*	*	*
	$P_{GD}$	133	154	223	254	319	404	514	589	649	750	1024	1094	1003	1066	*	*	*	*	*	*	*	*
45	$P_{GA}$	44.2	52.5	68.2	79.2	90.8	99.1	132	151	166	192	223	227	224	227	276	280	297	278	*	*	*	*
	$P_{GB}$	76.1	90.2	120	140	162	177	247	283	306	355	450	460	448	460	*	*	*	*	*	*	*	*
	$P_{GC}$	99.7	117	167	192	239	314	401	447	495	579	809	835	804	823	*	*	*	*	*	*	*	*
	$P_{GD}$	126	148	212	243	303	388	505	561	611	714	1006	1034	985	1009	*	*	*	*	*	*	*	*
50	$P_{GA}$	43.2	50.1	65.2	76.6	90.6	95.9	134	151	171	195	240	246	242	250	304	313	360	344	*	*	*	*
	$P_{GB}$	73.8	85.5	114	133	160	169	246	278	306	352	462	479	462	480	*	*	*	*	*	*	*	*
	$P_{GC}$	96.4	109	157	181	235	293	395	425	485	551	809	827	797	815	*	*	*	*	*	*	*	*
	$P_{GD}$	122	138	200	228	295	362	497	534	603	686	1009	1033	987	1012	*	*	*	*	*	*	*	*
56	$P_{GA}$	41.2	48.5	62.7	74.4	87.3	93.4	127	154	170	192	239	256	243	260	310	329	379	387	*	*	*	*
	$P_{GB}$	70.1	82.2	109	129	153	164	230	280	300	341	449	484	453	485	*	*	*	*	*	*	*	*
	$P_{GC}$	90.6	103	148	172	219	278	359	417	461	521	759	822	752	808	*	*	*	*	*	*	*	*
	$P_{GD}$	114	131	188	218	278	344	452	527	574	650	952	1028	934	1001	*	*	*	*	*	*	*	*
63	$P_{GA}$	39.1	47	59	71	83.5	92.5	122	154	166	194	235	255	241	262	307	336	397	411	*	*	*	*
	$P_{GB}$	66.1	79.2	102	122	145	160	219	276	288	338	434	473	439	474	*	*	*	*	*	*	*	*
	$P_{GC}$	84.1	100	136	161	204	272	334	411	432	510	706	770	700	760	*	*	*	*	*	*	*	*
	$P_{GD}$	106	126	172	205	259	338	421	518	538	637	889	973	876	950	*	*	*	*	*	*	*	*
71	$P_{GA}$	38.7	44.6	57.3	67.7	81.8	88.2	120	144	162	188	230	243	234	249	306	316	381	400	*	*	*	*
	$P_{GB}$	65.3	75	98.9	116	142	153	213	256	279	325	422	447	422	450	*	*	*	*	*	*	*	*
	$P_{GC}$	83.1	93.8	130	151	200	255	322	371	412	484	680	715	671	706	*	*	*	*	*	*	*	*
	$P_{GD}$	105	118	166	192	252	315	407	469	515	605	857	902	841	881	*	*	*	*	*	*	*	*
80	$P_{GA}$	36.8	42.1	56	63.3	77.6	83.5	113	136	158	178	223	237	227	241	292	315	369	384	*	*	*	*
	$P_{GB}$	61.9	70.3	96.6	108	134	143	201	241	272	308	406	434	406	433	*	*	*	*	*	*	*	*
	$P_{GC}$	77.3	87.2	125	139	185	236	297	345	398	449	642	688	635	676	*	*	*	*	*	*	*	*
	$P_{GD}$	97.9	110	160	177	236	293	377	437	496	564	812	868	795	846	*	*	*	*	*	*	*	*
90	$P_{GA}$	36.3	41.8	53.1	61.4	73.8	81.6	110	134	148	173	211	231	215	233	280	300	363	372	*	*	*	*
	$P_{GB}$	61.1	69.8	91.3	104	127	140	194	235	255	298	383	418	384	417	*	*	*	*	*	*	*	*
	$P_{GC}$	75.1	86.4	116	133	172	231	285	333	365	430	595	651	588	640	*	*	*	*	*	*	*	*
	$P_{GD}$	95.5	109	148	171	219	286	362	422	458	537	752	823	738	803	*	*	*	*	*	*	*	*
100	$P_{GA}$		39.7		60.4		78		128		171		221		226		294		379	*	*	*	*
	$P_{GB}$		66.2		102		133		223		293		397		397		*		*	*	*	*	*
	$P_{GC}$		80.3		129		172		215		308		415		604		595		*	*	*	*	*
	$P_{GD}$		101		165		266		392		520		764		748		*		*	*	*	*	*
112	$P_{GA}$		39.3		57.2		74.3		124		161												
	$P_{GB}$		65.6		97.3		127		216		274												
	$P_{GC}$		78.3		119		199		296		382												
	$P_{GD}$		99.4		153		248		377		479												

\* Auf Anfrage

$P_{GA}$  (kW) Getriebe ohne Zusatzkühlung \*\*)

$P_{GB}$  (kW) Getriebe mit Lüfterkühlung \*\*)

$P_{GC}$  (kW) Getriebe mit eingebauter Kühleisenschlange \*\*) \*\*\*)

$P_{GD}$  (kW) Getriebe mit Lüfter und eingebauter Kühleisenschlange \*\*) \*\*\*)

\*\* Werte gelten für:

Einschaltdauer: 100 %, Aufstellung in großer Halle, Höhenlage bis 1000 m

\*\*\*) Werte gelten für eine Kühlwassereintrittstemperatur von 20 °C ohne Begrenzung der Kühlwasseraustrittstemperatur.

Die Nachrechnung mit Begrenzung der Kühlwasseraustrittstemperatur ist auf Anfrage möglich.

\* On request

$P_{GA}$  (kW) Gear units without auxiliary cooling \*\*)

$P_{GB}$  (kW) Gear units with fan \*\*)

$P_{GC}$  (kW) Gear units with built-in cooling coil \*\*) \*\*\*)

$P_{GD}$  (kW) Gear units with fan and built-in cooling coil \*\*) \*\*\*)

\*\* Values refer to:

Operating cycle: 100 %, Installation in a large hall, Altitude up to 1000 m

\*\*\*) Values refer to a cooling water inlet temperature of 20 °C with unlimited cooling water outlet temperature.

A recalculation with a limited cooling water outlet temperature is possible on request.

\* Sur demande

$P_{GA}$  (kW) Réducteurs sans refroidissement supplémentaire \*\*)

$P_{GB}$  (kW) Réducteurs avec ventilateur \*\*)

$P_{GC}$  (kW) Réducteurs avec serpentin intégré \*\*) \*\*\*)

$P_{GD}$  (kW) Réducteurs avec ventilateur et serpentin intégré \*\*) \*\*\*)

\*\* Les valeurs sont valables pour:

Durée d'utilisation: 100 %, Implantation dans un grand hall, Altitude jusqu'à 1000 m

\*\*\*) Les données sont valables pour une température d'eau de refroidissement en entrée de 20 °C sans limitation de la température de l'eau en sortie.

Un calcul avec limitation de la température d'eau en sortie est possible sur demande.

# Zahnradgetriebe

Wärmegrenzleistungen

Bauart H3..

Größen 5 - 26

$n_1 = 1800 \text{ min}^{-1}$

# Gear Units

Thermal Capacities

Type H3..

Sizes 5 - 26

$n_1 = 1800 \text{ min}^{-1}$

# Réducteurs à engrenages

Capacités thermiques

Type H3..

Tailles 5 - 26

$n_1 = 1800 \text{ min}^{-1}$

Wärmegrenzleistungen $P_G$ (kW) / Thermal capacities $P_G$ (kW) / Capacités thermiques $P_G$ (kW)																						
$i_N$		Getriebegrößen / Gear unit sizes / Tailles réducteurs																				
		5	6	7	8	9	10	11	12	13	14	15	16	17	18	19	20	21	22	23	24	25
22.4	$P_{GA}$									141		*		*		*		*		*		*
	$P_{GB}$									352		446		416		*		*		*		*
	$P_{GC}$									713		1103		1076		*		*		*		*
	$P_{GD}$									881		1350		1290		*		*		*		*
25	$P_{GA}$	52.9		75.6		97.7		126		140		*		*		*		*		*		*
	$P_{GB}$	101		150		201		289		345		439	448	411	414	*	*	*	*	*	*	*
	$P_{GC}$	143		227		329		547		679		1043	1110	1020	1072	*	*	*	*	*	*	*
	$P_{GD}$	183		292		421		689		839		1282	1356	1226	1285	*	*	*	*	*	*	*
28	$P_{GA}$	51.6		77.6		99.8		129		148	165	*		*		*		*		*		*
	$P_{GB}$	97.9		153		202		285		346	392	460	466	439	439	*	*	*	*	*	*	*
	$P_{GC}$	135		226		321		516		644	751	1023	1064	1001	1033	*	*	*	*	*	*	*
	$P_{GD}$	174		292		411		655		803	932	1269	1312	1219	1252	*	*	*	*	*	*	*
31.5	$P_{GA}$	50.9	58.3	76	82.9	100	101	131	149	157	176	179	178	*	*	*	*	*	*	*	*	*
	$P_{GB}$	95.5	109	147	162	199	204	281	327	348	394	475	490	459	470	*	*	*	*	*	*	*
	$P_{GC}$	130	148	214	234	309	384	496	566	625	721	992	1043	978	1020	*	*	*	*	*	*	*
	$P_{GD}$	168	191	279	301	397	482	632	719	781	900	1240	1300	1200	1248	*	*	*	*	*	*	*
35.5	$P_{GA}$	49.8	56.9	75.1	85.3	99.2	104	132	152	164	184	194	201	184	187	208	*	*	*	*	*	*
	$P_{GB}$	92.9	105	145	164	195	203	277	322	348	396	477	507	467	493	*	*	*	*	*	*	*
	$P_{GC}$	124	140	206	232	296	375	472	535	601	686	933	1015	920	995	*	*	*	*	*	*	*
	$P_{GD}$	161	182	268	301	383	471	606	685	755	862	1176	1278	1144	1231	*	*	*	*	*	*	*
40	$P_{GA}$	47.3	55.7	72	82.7	94.9	101	130	151	164	186	199	205	190	194	223	227	*	*	*	*	*
	$P_{GB}$	87.7	102	138	158	186	199	268	315	339	390	469	495	462	484	*	*	*	*	*	*	*
	$P_{GC}$	116	135	192	219	277	359	447	511	570	659	887	947	878	930	*	*	*	*	*	*	*
	$P_{GD}$	149	173	250	285	357	453	573	655	719	831	1124	1199	1095	1160	*	*	*	*	*	*	*
45	$P_{GA}$	45.5	53.9	69.7	80.6	92	99.9	131	147	159	183	203	204	196	194	231	230	*	*	*	*	*
	$P_{GB}$	84	99.5	132	154	178	194	268	305	327	379	472	481	464	473	*	*	*	*	*	*	*
	$P_{GC}$	109	129	183	211	262	345	438	487	537	628	872	898	863	882	*	*	*	*	*	*	*
	$P_{GD}$	141	166	239	273	340	435	563	624	678	792	1107	1135	1077	1101	*	*	*	*	*	*	*
50	$P_{GA}$	44.7	51.9	67.3	78.7	92.9	98	135	152	170	193	231	234	228	233	280	285	303	274	*	*	*
	$P_{GB}$	81.7	94.6	126	147	177	186	269	303	332	381	495	512	491	508	*	*	*	*	*	*	*
	$P_{GC}$	106	120	172	199	258	322	433	465	530	601	879	897	864	881	*	*	*	*	*	*	*
	$P_{GD}$	137	155	225	257	332	407	558	598	673	766	1120	1146	1092	1117	*	*	*	*	*	*	*
56	$P_{GA}$	42.9	50.4	65	77	90.1	96.2	129	157	171	194	236	252	237	252	298	315	347	343	*	*	*
	$P_{GB}$	77.7	91.1	121	143	169	181	253	307	329	373	487	523	488	521	*	*	*	*	*	*	*
	$P_{GC}$	99.9	114	163	189	241	306	395	458	505	570	829	897	820	879	*	*	*	*	*	*	*
	$P_{GD}$	129	148	212	246	314	388	508	592	644	728	1063	1147	1040	1114	*	*	*	*	*	*	*
63	$P_{GA}$	40.8	49	61.5	73.9	86.8	96	126	159	170	198	238	258	243	262	307	334	386	394	*	*	*
	$P_{GB}$	73.4	88	113	135	160	177	242	304	317	372	475	517	479	517	*	*	*	*	*	*	*
	$P_{GC}$	92.7	110	150	178	225	299	368	452	474	560	774	844	767	832	*	*	*	*	*	*	*
	$P_{GD}$	120	143	194	232	293	381	475	584	606	716	998	1091	981	1064	*	*	*	*	*	*	*
71	$P_{GA}$	40.4	46.6	59.8	70.5	85.1	91.6	124	149	166	193	234	247	237	251	307	317	374	387	*	*	*
	$P_{GB}$	72.6	83.3	109	129	158	170	235	283	308	359	463	490	462	492	*	*	*	*	*	*	*
	$P_{GC}$	91.7	103	144	166	220	281	355	408	453	532	746	785	735	773	*	*	*	*	*	*	*
	$P_{GD}$	118	134	188	217	285	356	458	529	580	681	962	1012	943	987	*	*	*	*	*	*	*
80	$P_{GA}$	38.4	44	58.5	66	80.8	86.8	118	141	162	183	228	242	230	244	295	317	365	376	*	*	*
	$P_{GB}$	68.8	78.2	107	120	148	159	222	267	300	340	447	476	446	475	*	*	*	*	*	*	*
	$P_{GC}$	85.3	96.2	138	153	204	260	327	380	437	494	705	756	696	742	*	*	*	*	*	*	*
	$P_{GD}$	110	124	181	200	266	331	425	492	559	635	912	975	892	949	*	*	*	*	*	*	*
90	$P_{GA}$	38	43.6	55.4	64	76.9	85	114	139	152	179	217	236	219	237	284	304	362	368	*	*	*
	$P_{GB}$	67.9	77.6	101	116	141	155	215	260	282	330	422	460	422	458	*	*	*	*	*	*	*
	$P_{GC}$	82.9	95.3	128	147	190	254	314	367	401	473	654	715	645	703	*	*	*	*	*	*	*
	$P_{GD}$	107	123	168	193	247	323	409	476	516	605	846	925	829	902	*	*	*	*	*	*	*
100	$P_{GA}$		41.6		63.2		81.6		133		178		229		233		303		385	*	*	*
	$P_{GB}$		73.7		114		148		247		325		440		439		*		*	*	*	*
	$P_{GC}$		88.6		142		237		340		457		665		655		*		*	*	*	*
	$P_{GD}$		115		186		301		442		587		862		843		*		*	*	*	*
112	$P_{GA}$		41.2		59.9		77.8		130		168									*	*	*
	$P_{GB}$		73		108		141		240		305									*	*	*
	$P_{GC}$		86.4		132		220		327		421									*	*	*
	$P_{GD}$		112		173		281		426		542									*	*	*

\* Auf Anfrage

$P_{GA}$  (kW) Getriebe ohne Zusatzkühlung \*\*)

$P_{GB}$  (kW) Getriebe mit Lüfterkühlung \*\*)

$P_{GC}$  (kW) Getriebe mit eingebauter Kühlschlange \*\*) \*\*\*)

$P_{GD}$  (kW) Getriebe mit Lüfter und eingebauter Kühlschlange \*\*) \*\*\*)

\*\*\*) Werte gelten für:

Einschaltdauer: 100 %, Aufstellung in großer Halle, Höhenlage bis 1000 m

\*\*\*\*) Werte gelten für eine Kühlwassereintrittstemperatur von 20 °C ohne Begrenzung der Kühlwasseraustrittstemperatur.

Die Nachrechnung mit Begrenzung der Kühlwasseraustrittstemperatur ist auf Anfrage möglich.

\* On request

$P_{GA}$  (kW) Gear units without auxiliary cooling \*\*)

$P_{GB}$  (kW) Gear units with fan \*\*)

$P_{GC}$  (kW) Gear units with built-in cooling coil \*\*) \*\*\*)

$P_{GD}$  (kW) Gear units with fan and built-in cooling coil \*\*) \*\*\*)

\*\*\*) Values refer to:

Operating cycle: 100 %, Installation in a large hall, Altitude up to 1000 m

\*\*\*\*) Values refer to a cooling water inlet temperature of 20 °C with unlimited cooling water outlet temperature.

A recalculation with a limited cooling water outlet temperature is possible on request.

\* Sur demande

$P_{GA}$  (kW) Réducteurs sans refroidissement supplémentaire \*\*)

$P_{GB}$  (kW) Réducteurs avec ventilateur \*\*)

$P_{GC}$  (kW) Réducteurs avec serpentin intégré \*\*) \*\*\*)

$P_{GD}$  (kW) Réducteurs avec ventilateur et serpentin intégré \*\*) \*\*\*)

\*\*\*) Les valeurs sont valables pour:

Durée d'utilisation: 100 %, Implantation dans un grand hall, Altitude jusqu'à 1000 m

\*\*\*\*) Les données sont valables pour une température d'eau de refroidissement en entrée de 20 °C sans limitation de la température de l'eau en sortie.

Un calcul avec limitation de la température d'eau en sortie est possible sur demande.

# Zahnradgetriebe

Nennleistungen  
Bauart H4..  
Größen 7 - 26

# Gear Units

Nominal Power Ratings  
Type H4..  
Sizes 7 - 26

# Réducteurs à engrenages

Puissances nominales  
Type H4..  
Tailles 7 - 26

Nennleistungen P <sub>2N</sub> (kW) / Nominal power ratings P <sub>2N</sub> (kW) / Puissances nominales P <sub>2N</sub> (kW)																						
i <sub>N</sub>	n <sub>1</sub>	n <sub>2</sub>	Getriebegrößen / Gear unit sizes / Tailles réducteurs																			
			7	8	9	10	11	12	13	14	15	16	17	18	19	20	21	22	23	24	25	26
100	1800	18	40		67		116		170		288		376		565		791		1055*		1507*	
	1500	15	34		56		96		142		240		314		471		659		879		1256	
	1200	12	27		44		77		113		192		251		376		527		703		1005	
	1000	10	22		37		64		94		160		209		314		439		586		837	
112	1800	16.1	36		60		103		152		257	291	337	404	505	581	708	792	944*	1078*	1348*	1517*
	1500	13.4	30		50		86		127		214	242	280	336	420	484	589	659	785	898	1122	1262
	1200	10.7	24		39		69		101		171	193	224	268	336	386	470	526	627	717	896	1008
	1000	8.9	20		33		57		84		142	161	186	223	279	321	391	438	521	596	745	838
125	1800	14.4	32	41	53	66	92	117	136	170	230	260	301	361	452	520	633	708	844*	965*	1206*	1357*
	1500	12	27	34	44	55	77	98	113	141	192	217	251	301	376	433	527	590	703	804	1005	1130
	1200	9.6	21	27	35	44	61	78	91	113	153	173	201	241	301	346	422	472	562	643	804	904
	1000	8	18	22	29	37	51	65	75	94	128	144	167	201	251	289	351	393	469	536	670	753
140	1800	12.9	29	36	48	59	83	105	122	152	206	233	270	324	405	466	567	634	756*	864*	1080*	1215*
	1500	10.7	24	30	39	49	69	87	101	126	171	193	224	268	336	386	470	526	627	717	896	1008
	1200	8.6	19	24	32	39	55	70	81	101	137	155	180	216	270	310	378	423	504	576	720	810
	1000	7.1	16	20	26	32	45	57	67	84	113	128	148	178	223	256	312	349	416	475	594	669
160	1800	11.3	25	32	42	52	72	92	107	133	181	204	236	283	354	408	496	556	662*	757*	946*	1064*
	1500	9.4	21	26	35	43	60	76	89	111	150	170	196	236	295	339	413	462	551	629	787	885
	1200	7.5	17	21	28	34	48	61	71	88	120	135	157	188	235	270	329	369	439	502	628	706
	1000	6.3	14	17	23	29	40	51	59	74	100	114	131	158	197	227	277	310	369	422	527	593
180	1800	10	22	28	37	46	64	81	94	118	160	181	209	251	314	361	439	492	586*	670*	837*	942*
	1500	8.3	18	23	31	38	53	67	78	98	132	150	173	208	260	299	365	408	486	556	695	782
	1200	6.7	15	19	25	31	43	54	63	79	107	121	140	168	210	242	294	329	392	449	561	631
	1000	5.6	12	15	20	25	36	45	53	66	89	101	117	140	175	202	246	275	328	375	469	527
200	1800	9	20	25	33	41	58	73	85	106	144	163	188	226	282	325	395	442	527*	603*	753*	848*
	1500	7.5	17	21	28	34	48	61	71	88	120	135	157	188	235	270	329	369	439	502	628	706
	1200	6	13	17	22	27	38	49	56	70	96	108	125	150	188	216	263	295	351	402	502	565
	1000	5	11	14	18	23	32	40	47	59	80	90	104	125	157	180	219	246	293	335	418	471
224	1800	8	18	22	29	37	51	65	75	94	128	144	167	201	251	289	351	393	469*	536*	670*	753*
	1500	6.7	15	19	25	31	43	54	63	79	107	121	140	168	210	242	294	329	392	449	561	631
	1200	5.4	12	15	20	24	34	44	51	63	86	97	113	135	169	195	237	265	316	361	452	508
	1000	4.5	10	12	16	20	29	36	42	53	72	81	94	113	141	162	197	221	263	301	376	424
250	1800	7.2	16	20	26	33	46	58	68	85	115	130	150	180	226	260	316	354	422*	482*	603*	678*
	1500	6	13	17	22	27	38	49	56	70	96	108	125	150	188	216	263	295	351	402	502	565
	1200	4.8	10	13	17	22	30	39	45	56	76	86	100	120	150	173	211	236	281	321	402	452
	1000	4	9	11	14	18	25	32	37	47	64	72	83	100	125	144	175	196	234	268	335	376
280	1800	6.4	14	18	23	29	41	52	60	75	102	115	134	160	201	231	281	314	375*	428*	536*	603*
	1500	5.4	12	15	20	24	34	44	51	63	86	97	113	135	169	195	237	265	316	361	452	508
	1200	4.3	9.7	12	16	19	27	35	40	50	68	77	90	108	135	155	189	211	252	288	360	405
	1000	3.6	8.1	10	13	16	23	29	34	42	57	65	75	90	113	130	158	177	211	241	301	339
315	1800	5.7	12	16	21	26	36	46	54	67	91	103	119	143	179	205	250	280	334*	381*	477*	537*
	1500	4.8	10	13	17	22	30	39	45	56	76	86	100	120	150	173	211	236	281	321	402	452
	1200	3.8	8.6	10	14	17	24	31	36	44	60	68	79	95	119	137	167	187	222	254	318	358
	1000	3.2	7.2	9.1	11	14	20	26	30	37	51	57	67	80	100	115	140	157	187	214	268	301
355	1800	5.1	10	14	19	23	32	41	48	60	74	92	102	128	154	184	218	250	299*	341*	427*	480*
	1500	4.2	8.6	11	15	19	27	34	39	49	61	76	84	105	127	151	180	206	246	281	351	395
	1200	3.4	6.9	9.6	12	15	21	27	32	40	49	61	68	85	103	122	145	167	199	227	284	320
	1000	2.8	5.7	7.9	10	12	18	22	26	33	41	50	56	70	85	101	120	137	164	187	234	263
400	1800	4.5		12		20		36		53		74		105		157		219		301*		424*
	1500	3.8		10		17		31		44		62		88		133		185		254		358
	1200	3		8.5		13		24		35		49		70		105		146		201		282
	1000	2.5		7.1		11		20		29		41		58		87		121		167		235
450	1800	4		10		17		32		47												
	1500	3.3		8.7		14		26		39												
	1200	2.7		7.1		12		22		31												
	1000	2.2		5.8		9.8		17		26												

\* Getriebe nur auf Anfrage

\* Gear units only on request

\* Réducteur à engrenages seulement sur demande

### Zahnradgetriebe

Nenn-Abtriebsdrehmomente  
Bauart H4..  
Größen 7 - 26

### Gear Units

Nominal Output Torques  
Type H4..  
Sizes 7 - 26

### Réducteurs à engrenages

Couples nominaux de sortie  
Type H4..  
Tailles 7 - 26

Nenn-Abtriebsdrehmomente T <sub>2N</sub> (kNm) Nominal output torques T <sub>2N</sub> (kNm) / Couples nominaux de sortie T <sub>2N</sub> (kNm)																									
i <sub>N</sub>	Getriebegrößen / Gear unit sizes / Tailles réducteurs																								
	3	4	5	6	7	8	9	10	11	12	13	14	15	16	17	18	19	20	21	22	23	24	25	26	
1.25	2.9		8		15.2		24.7																		
1.4	3.1		8.2		15.9		25.6																		
1.6	3.3		8.6		16.3		27.1		46		67.4														
1.8	2.7		8.8		17.4		28		47.6		70.9														
2	2.8		9.4		17.8		28.7		49.1		72.9		129												
2.24	2.8		9.6		17.8		28.7		50.6		75.2		130												
2.5	2.9		9.6		17.8		28.7		50.6		77														
2.8	3.1		9.6		17.1		27.9		50.6		77														
3.15	3.1		9.6		17.4		28.7		48.1		73.1														
3.55	3.2		9.5		17.8		28.6		50.2		74.4														
4	3.2		9.6		17.8		28.7		50.6		75.7		130		173		245								
4.5	2.5		7.7		15.8		24.6		46		61.6		109		146		216								
5	2.4		7.2		13.8		23.5		38.7		58.3		95		124		174								
5.6	2.3		6.9		13.1		20.1		36.5		55.4		90.4		118		150								
6.3		6.3	10.7		20.3		33.7		59.3		86		143		195		292								
7.1		6.5	11.2		20.3		33.7		59.3		86		143	160	195	230	292	335	410						
8		6.7	11.2	13.5	20.3	25.6	33.7	42.2	59.3	73.8	86	107	143	160	195	230	292	335	410	458					
9		6.7	11.2	14.4	20.3	25.6	33.7	42.2	59.3	73.8	86	107	143	160	195	230	292	335	410	458	540				
10		6.3	10.5	14.4	20.3	25.6	33.7	42.2	59.3	73.8	86	107	143	160	195	230	292	335	410	458	540	620			
11.2		6.3	10.6	14.4	20.3	25.6	33.7	42.2	59.3	73.8	86	107	143	160	195	230	292	335	410	458	540	620	780		
12.5		6.7	11.2	13.5	20.2	25.6	33.7	42.2	59.3	73.8	86	107	143	160	195	230	292	335	410	458	540	620	780	880	
14		6.7	11.2	13.5	20.3	25.6	33.7	42.2	59.3	73.8	86	107	143	160	195	230	292	335	410	458	540	620	780	880	
16		6.7	11.2	14.4	20.3	25.5	33.7	42.2	59.3	73.8	86	107	143	160	195	230	292	335	410	458	540	620	780	880	
18		6.3	10.5	14.4	19	25.6	33.7	42.2	59.3	73.8	86	107	143	160	195	230	292	335	410	458	540	620	780	880	
20		6.6	11.2	14.4	19	25.6	33.7	42.2	59.3	73.8	86	107	143	160	195	230	292	335	410	458	540	620	780	880	
22.4		6.3	10.9	13.5	19.8	24	33.1	42.2	58.3	73.8	88	107	153	160	200	230	300	335	420	458	560	620	800	880	
25			11.6	14.3	21.7	24	35.7	42.2	63.5	73.8	88	107	153	173	200	240	300	345	420	470	560	640	800	900	
28			11.6	13.9	21.7	25	35.7	41.6	63.5	72.5	88	109	153	173	200	240	300	345	420	470	560	640	800	900	
31.5			11.6	15.5	21.7	27.2	35.7	43.8	63.5	77.2	88	109	153	173	200	240	300	345	420	470	560	640	800	900	
35.5			11.6	15.5	21.7	27.2	35.7	43.8	63.5	77.2	88	109	153	173	200	240	300	345	420	470	560	640	800	900	
40			11.6	15.5	21.7	27.2	35.7	43.8	63.5	77.2	88	109	153	173	200	240	300	345	420	470	560	640	800	900	
45			11.6	15.5	21.7	27.2	35.7	43.8	63.5	77.2	88	109	153	173	200	240	300	345	420	470	560	640	800	900	
50			11.6	15.5	21.7	27.2	35.7	43.8	63.5	77.2	88	109	153	173	200	240	300	345	420	470	560	640	800	900	
56			11.6	15.5	21.7	27.2	35.7	43.8	63.5	77.2	88	109	153	173	200	240	300	345	420	470	560	640	800	900	
63			11.6	15.5	21.7	27.2	35.7	43.8	63.5	77.2	88	109	153	173	200	240	300	345	420	470	560	640	800	900	
71			11.6	15.5	21.7	27.2	35.7	43.8	63.5	77.2	88	109	153	173	200	240	300	345	420	470	560	640	800	900	
80			11.6	15.5	21.7	27.2	35.7	43.8	63.5	77.2	88	109	153	173	200	240	300	345	420	470	560	640	800	900	
90			11.6	15.5	20	27.2	34.5	43.8	63.5	77.2	88	109	153	173	200	240	290	345	410	470	560	640	800	900	
100				14.5	21.7	27.2	35.7	43.8	61.6	77.2	90.7	109	153	173	200	226	300	335	420	465	560	640	800	900	
112				15	21.7	25.2	35.7	42.8	61.6	77.2	90.7	109	153	173	200	240	300	345	420	470	560	640	800	900	
125					21.7	27.2	35.7	44.2	61.6	78	90.7	113	153	173	200	240	300	345	420	470	560	640	800	900	
140					21.7	27.2	35.7	44.2	61.6	78	90.7	113	153	173	200	240	300	345	420	470	560	640	800	900	
160					21.7	27.2	35.7	44.2	61.6	78	90.7	113	153	173	200	240	300	345	420	470	560	640	800	900	
180					21.7	27.2	35.7	44.2	61.6	78	90.7	113	153	173	200	240	300	345	420	470	560	640	800	900	
200					21.7	27.2	35.7	44.2	61.6	78	90.7	113	153	173	200	240	300	345	420	470	560	640	800	900	
224					21.7	27.2	35.7	44.2	61.6	78	90.7	113	153	173	200	240	300	345	420	470	560	640	800	900	
250					21.7	27.2	35.7	44.2	61.6	78	90.7	113	153	173	200	240	300	345	420	470	560	640	800	900	
280					21.7	27.2	35.7	44.2	61.6	78	90.7	113	153	173	200	240	300	345	420	470	560	640	800	900	
315					21.7	27.2	35.7	44.2	61.6	78	90.7	113	153	173	200	240	300	345	420	470	560	640	800	900	
355					19.6	27.2	35.7	44.2	61.6	78	90.7	113	140	173	192	240	290	345	410	470	560	640	800	900	
400						27.2		44.2		78		113		158		223		335		465		640		900	
450						25.3		42.8		78		113													

## Zahnradgetriebe

Wärmegrenzleistungen

Bauart H4..

Größen 7 - 26

$n_1 = 1000 \text{ min}^{-1}$

## Gear Units

Thermal Capacities

Type H4..

Sizes 7 - 26

$n_1 = 1000 \text{ min}^{-1}$

## Réducteurs à engrenages

Capacités thermiques

Type H4..

Tailles 7 - 26

$n_1 = 1000 \text{ min}^{-1}$

Wärmegrenzleistungen $P_G$ (kW) / Thermal capacities $P_G$ (kW) / Capacités thermiques $P_G$ (kW)																					
$i_N$		Getriebegrößen / Gear unit sizes / Tailles réducteurs																			
		7	8	9	10	11	12	13	14	15	16	17	18	19	20	21	22	23	24	25	26
100	$P_{GA}$	43.6		60.8		90.1		120		161		180		253		346		*		*	
112	$P_{GA}$	42		58.2		89.4		117		154	166	173	185	243	260	340	350	*	*	*	*
125	$P_{GA}$	40.8	46.8	56.4	61.1	85.8	99.7	114	128	149	160	167	177	235	249	330	344	*	*	*	*
140	$P_{GA}$	38.7	44.9	54.6	58.5	83	98.9	110	125	144	153	161	171	227	241	313	334	*	*	*	*
160	$P_{GA}$	37.2	43.6	51.6	56.7	79	95.3	104	121	138	148	154	165	218	232	301	317	*	*	*	*
180	$P_{GA}$	35.8	41.4	49.4	54.9	76.2	91.8	100	118	136	142	151	158	208	224	297	304	*	*	*	*
200	$P_{GA}$	34.4	39.9	47.8	51.8	72	87.6	98.2	111	132	139	146	156	201	214	280	300	*	*	*	*
224	$P_{GA}$	32.4	38.2	45.9	49.6	69	84.4	93.7	107	123	136	136	151	193	206	268	283	*	*	*	*
250	$P_{GA}$	31	37	43.8	48.2	65.6	79.7	89.1	104	117	126	130	141	183	198	253	270	*	*	*	*
280	$P_{GA}$	30.1	34.7	42.5	46.2	63.1	76.7	86.3	99.1	113	120	126	133	176	188	243	255	*	*	*	*
315	$P_{GA}$	29.4	33.3	40.5	44.1	61.6	72.7	82.8	95.5	108	116	121	130	172	181	233	245	*	*	*	*
355	$P_{GA}$	28.1	32.3	39.8	42.8	58.6	69.9	78.9	91.9	106	111	118	124	164	177	222	236	*	*	*	*
400	$P_{GA}$		31.6		40.8		68.3		88.3		109		121		168		225		*		*
450	$P_{GA}$		30.1		40.1		64.9		84.2												

$n_1 = 1200 \text{ min}^{-1}$

$n_1 = 1200 \text{ min}^{-1}$

$n_1 = 1200 \text{ min}^{-1}$

Wärmegrenzleistungen $P_G$ (kW) / Thermal capacities $P_G$ (kW) / Capacités thermiques $P_G$ (kW)																					
$i_N$		Getriebegrößen / Gear unit sizes / Tailles réducteurs																			
		7	8	9	10	11	12	13	14	15	16	17	18	19	20	21	22	23	24	25	26
100	$P_{GA}$	45.4		63.1		92.4		121		160		178		246		325		*		*	
112	$P_{GA}$	43.9		60.6		92.4		120		156	167	173	185	241	257	329	335	*	*	*	*
125	$P_{GA}$	42.7	49	58.8	63.7	89	103	117	132	152	162	169	179	237	250	325	335	*	*	*	*
140	$P_{GA}$	40.6	47.1	57.1	61.1	86.5	102	114	129	148	158	164	175	231	245	314	332	*	*	*	*
160	$P_{GA}$	39.1	45.7	54.1	59.4	82.5	99.4	108	126	143	153	159	170	224	238	305	319	*	*	*	*
180	$P_{GA}$	37.7	43.6	52	57.7	80	96.2	105	123	142	148	157	165	216	232	306	313	*	*	*	*
200	$P_{GA}$	36.3	42	50.3	54.5	75.7	92.1	103	117	139	146	153	163	211	224	292	313	*	*	*	*
224	$P_{GA}$	34.2	40.3	48.4	52.4	72.8	89	98.8	113	130	144	144	159	204	217	283	299	*	*	*	*
250	$P_{GA}$	32.7	39	46.2	50.8	69.2	84	94	110	123	133	137	148	193	209	267	285	*	*	*	*
280	$P_{GA}$	31.7	36.6	44.9	48.7	66.6	80.9	91.1	104	120	126	133	141	186	198	257	269	*	*	*	*
315	$P_{GA}$	31.1	35.1	42.8	46.5	64.9	76.7	87.3	100	114	122	127	137	182	191	246	259	*	*	*	*
355	$P_{GA}$	29.6	34	42	45.2	61.8	73.8	83.3	96.9	112	118	124	131	173	187	235	249	*	*	*	*
400	$P_{GA}$		33.4		43.1		72		93.2		115		128		177		238		*		*
450	$P_{GA}$		31.7		42.3		68.5		88.8												

\* Auf Anfrage

\* On request

\* Sur demande

$P_{GA}$  (kW) Getriebe ohne Zusatzkühlung \*\*)

$P_{GA}$  (kW) Gear units without auxiliary cooling \*\*)

$P_{GA}$  (kW) Réducteurs sans refroidissement supplémentaire \*\*)

\*\*\*) Werte gelten für:  
Einschaltdauer: 100 %  
Aufstellung in großer Halle  
Höhenlage bis 1000 m

\*\*\*) Values refer to:  
Operating cycle: 100 %  
Installation in a large hall  
Altitude up to 1000 m

\*\*\*) Les valeurs sont valables pour:  
Durée d'utilisation: 100 %  
Implantation dans un grand hall  
Altitude jusqu'à 1000 m



## Zahnradgetriebe

Wärmegrenzleistungen

Bauart H4..

Größen 7 - 26

$n_1 = 1500 \text{ min}^{-1}$

## Gear Units

Thermal Capacities

Type H4..

Sizes 7 - 26

$n_1 = 1500 \text{ min}^{-1}$

## Réducteurs à engrenages

Capacités thermiques

Type H4..

Tailles 7 - 26

$n_1 = 1500 \text{ min}^{-1}$

Wärmegrenzleistungen $P_G$ (kW) / Thermal capacities $P_G$ (kW) / Capacités thermiques $P_G$ (kW)																					
$i_N$		Getriebegrößen / Gear unit sizes / Tailles réducteurs																			
		7	8	9	10	11	12	13	14	15	16	17	18	19	20	21	22	23	24	25	26
100	$P_{GA}$	48.7		67.6		99.1		130		172		190		264		348		*		*	
112	$P_{GA}$	47.1		65.1		99.1		129		167	179	186	198	259	276	352	358	*	*	*	*
125	$P_{GA}$	45.8	52.5	63.1	68.3	95.5	110	126	142	163	174	181	192	254	268	348	359	*	*	*	*
140	$P_{GA}$	43.5	50.5	61.3	65.6	92.8	110	123	139	158	169	176	188	248	263	336	356	*	*	*	*
160	$P_{GA}$	41.9	49.1	58	63.7	88.5	106	116	135	153	164	171	182	240	255	327	342	*	*	*	*
180	$P_{GA}$	40.4	46.7	55.8	61.9	85.8	103	113	132	152	159	169	177	232	249	329	335	*	*	*	*
200	$P_{GA}$	38.9	45.1	54	58.5	81.3	98.9	110	126	149	157	164	175	226	240	314	335	*	*	*	*
224	$P_{GA}$	36.7	43.2	52	56.2	78.1	95.5	106	121	140	154	154	170	219	233	303	321	*	*	*	*
250	$P_{GA}$	35.1	41.9	49.6	54.5	74.2	90.2	100	118	132	143	147	159	208	224	287	305	*	*	*	*
280	$P_{GA}$	34	39.3	48.2	52.3	71.4	86.8	97.7	112	128	135	143	151	199	213	276	289	*	*	*	*
315	$P_{GA}$	33.3	37.6	45.9	49.9	69.7	82.2	93.7	108	122	131	136	147	195	204	264	278	*	*	*	*
355	$P_{GA}$	31.8	36.5	45.1	48.5	66.3	79.2	89.4	104	120	126	133	141	186	200	252	267	*	*	*	*
400	$P_{GA}$		35.8		46.2		77.3		100		123		138		190		255		*		*
450	$P_{GA}$		34		45.4		73.5		95.3												

$n_1 = 1800 \text{ min}^{-1}$

$n_1 = 1800 \text{ min}^{-1}$

$n_1 = 1800 \text{ min}^{-1}$

Wärmegrenzleistungen $P_G$ (kW) / Thermal capacities $P_G$ (kW) / Capacités thermiques $P_G$ (kW)																					
$i_N$		Getriebegrößen / Gear unit sizes / Tailles réducteurs																			
		7	8	9	10	11	12	13	14	15	16	17	18	19	20	21	22	23	24	25	26
100	$P_{GA}$	51.1		70.7		102		134		174		191		263		335		*		*	
112	$P_{GA}$	49.5		68.2		103		133		171	183	189	201	262	279	349	351	*	*	*	*
125	$P_{GA}$	48.1	55.2	66.3	71.7	99.8	115	131	147	168	179	186	197	259	273	350	358	*	*	*	*
140	$P_{GA}$	45.9	53.2	64.5	69	97.3	115	128	145	165	175	183	194	255	271	343	361	*	*	*	*
160	$P_{GA}$	44.2	51.7	61.1	67.1	93	111	122	142	160	171	178	190	249	265	336	350	*	*	*	*
180	$P_{GA}$	42.7	49.4	58.9	65.3	90.4	108	119	139	160	167	177	185	243	261	342	348	*	*	*	*
200	$P_{GA}$	41.2	47.7	57.1	61.9	85.8	104	116	133	157	165	173	184	238	253	329	352	*	*	*	*
224	$P_{GA}$	38.9	45.7	55	59.5	82.7	101	112	128	148	163	163	180	232	247	321	340	*	*	*	*
250	$P_{GA}$	37.1	44.3	52.5	57.7	78.5	95.4	106	125	140	151	155	168	220	237	304	323	*	*	*	*
280	$P_{GA}$	36	41.6	51	55.3	75.6	91.8	103	118	136	143	151	160	211	225	292	306	*	*	*	*
315	$P_{GA}$	35.3	39.8	48.6	52.8	73.7	87	99.1	114	129	139	144	155	207	216	280	294	*	*	*	*
355	$P_{GA}$	33.6	38.6	47.7	51.3	70.1	83.8	94.6	110	127	134	141	149	197	212	267	283	*	*	*	*
400	$P_{GA}$		37.9		48.9		81.8		105		130		146		201		270		*		*
450	$P_{GA}$		36		48		77.8		100												

\* Auf Anfrage

\* On request

\* Sur demande

$P_{GA}$  (kW) Getriebe ohne Zusatzkühlung \*\*)

$P_{GA}$  (kW) Gear units without auxiliary cooling \*\*)

$P_{GA}$  (kW) Réducteurs sans refroidissement supplémentaire \*\*)

\*\*\*) Werte gelten für:  
Einschaltdauer: 100 %  
Aufstellung in großer Halle  
Höhenlage bis 1000 m

\*\*\*) Values refer to:  
Operating cycle: 100 %  
Installation in a large hall  
Altitude up to 1000 m

\*\*\*) Les valeurs sont valables pour:  
Durée d'utilisation: 100 %  
Implantation dans un grand hall  
Altitude jusqu'à 1000 m

# Zahnradgetriebe

Nennleistungen  
Bauart B2..  
Größen 4 - 26

# Gear Units

Nominal Power Ratings  
Type B2..  
Sizes 4 - 26

# Réducteurs à engrenages

Puissances nominales  
Type B2..  
Tailles 4 - 26

3

Nennleistungen P <sub>2N</sub> (kW) / Nominal power ratings P <sub>2N</sub> (kW) / Puissances nominales P <sub>2N</sub> (kW)																								
i <sub>N</sub>	n <sub>1</sub>	n <sub>2</sub>	Getriebegrößen / Gear unit sizes / Tailles réducteurs																					
			4	5	6	7	8	9	10	11	12	13	14	15	16	17	18	19	20	21	22	23	24	25
5	1800	360	229	354		716		1127		1734*		2585*		4598*										
	1500	300	191	295		596		939		1445		2154		3832*										
	1200	240	153	236		477		751		1156		1723		3065*										
	1000	200	127	196		397		626		963		1436		2554										
5.6	1800	321	208	315		638		1005		1616*		2339*		4100*	4537*									
	1500	268	173	263		533		839		1349		1953		3423*	3788*									
	1200	214	138	210		425		670		1077		1559		2733*	3025*	4369*								
	1000	179	116	176		356		560		901		1304		2286	2530	3654*								
6.3	1800	286	185	281	359	569	712	895	1138	1503*	1760*	2210*	2551*	3893*	4222*									
	1500	238	154	234	299	473	593	745	947	1251	1465	1839	2123	3239*	3513*	4859*								
	1200	190	123	187	238	378	473	594	756	998	1169	1468	1695	2586*	2805*	3879*								
	1000	159	103	156	199	316	396	497	632	835	978	1228	1418	2164	2347	3246*								
7.1	1800	254	164	250	319	505	633	795	1010	1393*	1619*	2018*	2321*	3510*	3856*									
	1500	211	136	207	265	419	525	660	839	1157	1345	1676	1928	2916*	3203*	4308*								
	1200	169	109	166	212	336	421	529	672	927	1077	1343	1544	2335*	2565*	3450*	4070*							
	1000	141	91	138	177	280	351	441	561	773	899	1120	1288	1948	2140	2879	3395*							
8	1800	225	146	221	282	447	560	704	895	1272*	1486*	1884*	2155*	3109*	3486*	4594*								
	1500	188	122	185	236	374	468	588	748	1063	1242	1574	1801	2598	2913*	3838*	4527*							
	1200	150	97	147	188	298	373	469	596	848	991	1256	1437	2073	2324*	3062*	3612*							
	1000	125	81	123	157	248	311	391	497	706	825	1047	1197	1727	1937	2552	3010							
9	1800	200	129	196	251	397	498	626	795	1130*	1365*	1698*	1981*	2764*	3099*	4083*	4816*							
	1500	167	108	164	209	332	416	522	664	944	1140	1418	1654	2308	2588	3409*	4021*							
	1200	133	86	130	167	264	331	416	529	752	908	1129	1317	1838	2061	2715*	3203*							
	1000	111	72	109	139	220	276	347	441	627	757	942	1099	1534	1720	2266	2673							
10	1800	180	116	177	226	358	448	563	716	1017*	1249*	1528*	1862*	2487*	2789*	3675*	4335*							
	1500	150	97	147	188	298	373	469	596	848	1041	1273	1551	2073	2324	3062*	3612*							
	1200	120	77	118	150	238	299	375	477	678	833	1019	1241	1658	1859	2450*	2890*							
	1000	100	64	98	125	198	249	313	397	565	694	849	1034	1382	1549	2041	2408							
11.2	1800	161	104	158	202	320	401	504	640	910*	1117*	1367*	1709*	2225*	2495*	3287*	3877*							
	1500	134	86	131	168	266	333	419	533	757	930	1137	1422	1852	2076	2736*	3227*							
	1200	107	69	105	134	212	266	335	425	605	742	908	1136	1478	1658	2184*	2576*							
	1000	89	57	87	111	177	221	278	354	503	617	755	944	1230	1379	1817	2143							
12.5	1800	144			180		358		572		999*		1528*		2231*		3468*							
	1500	120			150		299		477		833		1274		1859		2890*							
	1200	96			120		239		381		666		1019		1487		2312*							
	1000	80			100		199		318		555		849		1239		1926							
14	1800	129			162		321		513		895*		1369*											
	1500	107			134		266		425		742		1136											
	1200	86			108		214		342		597		913											
	1000	71			89		176		282		492		753											

Druckschmierung bei Horizontalgetrieben erforderlich    
  Forced lubrication required on horizontal gear units    
  La lubrification sous pression est nécessaire en position horizontale pour ces réducteurs  
 \* Getriebe nur auf Anfrage    
  \* Gear units only on request    
  \* Réducteur à engrenages seulement sur demande

### Zahnradgetriebe

Nenn-Abtriebsdrehmomente  
Bauart B2..  
Größen 4 - 26

### Gear Units

Nominal Output Torques  
Type B2..  
Sizes 4 - 26

### Réducteurs à engrenages

Couples nominaux de sortie  
Type B2..  
Tailles 4 - 26

Nenn-Abtriebsdrehmomente $T_{2N}$ (kNm) Nominal output torques $T_{2N}$ (kNm) / Couples nominaux de sortie $T_{2N}$ (kNm)																							
$i_N$	Getriebegrößen / Gear unit sizes / Tailles réducteurs																						
	4	5	6	7	8	9	10	11	12	13	14	15	16	17	18	19	20	21	22	23	24	25	26
5	6.1	9.4		19		29.9		46		68.6		122											
5.6	6.2	9.4		19		29.9		48.1		69.6		122	135	195									
6.3	6.2	9.4	12	19	23.8	29.9	38	50.2	58.8	73.8	85.2	130	141	195									
7.1	6.2	9.4	12	19	23.8	29.9	38	52.4	60.9	75.9	87.3	132	145	195	230								
8	6.2	9.4	12	19	23.8	29.9	38	54	63.1	80	91.5	132	148	195	230								
9	6.2	9.4	12	19	23.8	29.9	38	54	65.2	81.1	94.6	132	148	195	230								
10	6.2	9.4	12	19	23.8	29.9	38	54	66.3	81.1	98.8	132	148	195	230								
11.2	6.2	9.4	12	19	23.8	29.9	38	54	66.3	81.1	101	132	148	195	230								
12.5	5.5	9.4	12	17	23.8	28	38	52.4	66.3	79.5	101	132	148	195	230	250		340					
14	6	9.8	12	18.2	23.8	29.5	38	56.7	66.3	81.6	101	137	148	195	230	262	295	360	405				
16	6.6	10.5	12	19.8	21.5	31	35.6	59.9	66.3	83.8	99.4	142	154	200	230	275	308	380	422				
18	6.7	11.3	12.6	21.1	23.1	33.9	37.5	62	69.5	86.7	102	148	160	200	240	288	320	400	438				
20	6.7	11.6	13.2	21.7	25	35.7	39.3	63.5	72.7	90.7	105	153	167	200	240	300	332	420	455	560		800	
22.4	6.7	11.6	14.2	21.7	26.5	35.7	41.8	63.5	75.6	90.7	108	153	173	200	240	300	345	420	470	560	640	800	900
25	6.7	11.6	15.5	21.7	27.2	35.7	43.8	63.5	77.2	90.7	113	153	173	200	240	300	345	420	470	560	640	800	900
28	6.7	11.6	15.5	21.7	27.2	35.7	43.8	63.5	77.2	90.7	113	153	173	200	240	300	345	420	470	560	640	800	900
31.5	6.7	11.6	15.5	21.7	27.2	35.7	43.8	63.5	77.2	90.7	113	153	173	200	240	300	345	420	470	560	640	800	900
35.5	6.7	11.6	15.5	21.7	27.2	35.7	43.8	63.5	77.2	90.7	113	153	173	200	240	300	345	420	470	560	640	800	900
40	6.7	11.6	15.5	21.7	27.2	35.7	43.8	63.5	77.2	90.7	113	153	173	200	240	300	345	420	470	560	640	800	900
45	6.7	11.6	15.5	21.7	27.2	35.7	43.8	63.5	77.2	90.7	113	153	173	200	240	300	345	420	470	560	640	800	900
50	6.7	11.6	15.5	21.7	27.2	35.7	43.8	63.5	77.2	90.7	113	153	173	200	240	300	345	420	470	560	640	800	900
56	6.7	11.6	15.5	21.7	27.2	35.7	43.8	63.5	77.2	90.7	113	153	173	200	240	300	345	420	470	560	640	800	900
63	6.6	11.4	15.5	21.4	27.2	35.7	43.8	63.5	77.2	90.7	113	153	173	200	240	300	345	420	470	560	640	800	900
71	6.6	11	15.5	20	27.2	34	43.8	60	77.2	90.7	113	153	173	200	240	300	345	420	470	560	640	800	900
80		11.6	14	21.7	26.9	35.7	43.8	61.6	77.2	90.7	113	153	173	200	240	300	345	420	470	560	640	800	900
90		11.6	14	21.7	25.2	35.7	43	61.6	75	90.7	113	153	173	200	240	300	345	420	470	560	640	800	900
100		11.6	15.5	21.7	27.2	35.7	44.2	61.6	78	90.7	113	153	173	200	240	300	345	420	470	560	640	800	900
112		11.6	15.5	21.7	27.2	35.7	44.2	61.6	78	90.7	113	153	173	200	240	300	345	420	470	560	640	800	900
125		11.6	15.5	21.7	27.2	35.7	44.2	61.6	78	90.7	113	153	173	200	240	300	345	420	470	560	640	800	900
140		11.6	15.5	21.7	27.2	35.7	44.2	61.6	78	90.7	113	153	173	200	240	300	345	420	470	560	640	800	900
160		11.6	15.5	21.7	27.2	35.7	44.2	61.6	78	90.7	113	153	173	200	240	300	345	420	470	560	640	800	900
180		11.6	15.5	21.7	27.2	35.7	44.2	61.6	78	90.7	113	153	173	200	240	300	345	420	470	560	640	800	900
200		11.6	15.5	21.7	27.2	35.7	44.2	61.6	78	90.7	113	153	173	200	240	300	345	420	470	560	640	800	900
224		11.6	15.5	21.7	27.2	35.7	44.2	61.6	78	90.7	113	153	173	200	240	300	345	420	470	560	640	800	900
250		11.6	15.5	21.7	27.2	35.7	44.2	61.6	78	90.7	113	153	173	200	240	300	345	420	470	560	640	800	900
280		11.6	15.5	21.7	27.2	35.3	44.2	61.6	78	90.7	113	153	173	200	240	300	345	420	470	560	640	800	900
315		11.2	15.5	20.5	27.2	34	44.2	60	78	90.7	113	153	173	200	240	300	345	420	470	560	640	800	900
355			15.5		26.5		44.2		78		113		173		240		345		470		640		900
400			14.5		25.5		43		75		113												

**B3** siehe Seiten 44 - 49  
see pages 44 - 49  
voir pages 44 - 49

**B4** siehe Seiten 50 - 53  
see pages 50 - 53  
voir pages 50 - 53

## Zahnradgetriebe

Wärmegrenzleistungen

Bauart B2..

Größen 4 - 26

$n_1 = 1000 \text{ min}^{-1}$

## Gear Units

Thermal Capacities

Type B2..

Sizes 4 - 26

$n_1 = 1000 \text{ min}^{-1}$

## Réducteurs à engrenages

Capacités thermiques

Type B2..

Tailles 4 - 26

$n_1 = 1000 \text{ min}^{-1}$

Wärmegrenzleistungen P <sub>G</sub> (kW) / Thermal capacities P <sub>G</sub> (kW) / Capacités thermiques P <sub>G</sub> (kW)																									
i <sub>N</sub>		Getriebegrößen / Gear unit sizes / Tailles réducteurs																							
		4	5	6	7	8	9	10	11	12	13	14	15	16	17	18	19	20	21	22	23	24	25	26	
5	P <sub>GA</sub>	48.3	58.6		77.4		87.1		*		*		*												
	P <sub>GB</sub>	113	155		246		297		487		684		788												
	P <sub>GC</sub>	137	206		319		398		677		1344		1821												
	P <sub>GD</sub>	194	291		468		578		984		1838		2383												
5.6	P <sub>GA</sub>	47.7	59.8		78.3		90.2		120		*		*		*										
	P <sub>GB</sub>	109	153		232		282		481		688		804		859										
	P <sub>GC</sub>	132	199		293		367		643		1289		1763		2055										
	P <sub>GD</sub>	187	282		432		535		943		1789		2333		2689										
6.3	P <sub>GA</sub>	47	58.7	68.3	75.8	89.9	89.4	98.3	122	142	*	*	*	*	*										
	P <sub>GB</sub>	105	145	170	216	261	265	300	441	556	637	771	779	838	850										
	P <sub>GC</sub>	126	185	264	266	388	333	460	566	976	1132	1411	1627	1782	1909										
	P <sub>GD</sub>	179	263	359	393	548	489	643	834	1340	1574	1954	2168	2366	2530										
7.1	P <sub>GA</sub>	45	57.2	69	74.3	88.9	89.1	99.3	132	158	151	176	*	*	*	*									
	P <sub>GB</sub>	99	137	166	203	246	250	284	436	546	637	768	756	815	838	897									
	P <sub>GC</sub>	116	171	257	244	357	306	422	545	931	1097	1352	1508	1645	1787	1919									
	P <sub>GD</sub>	164	243	349	362	506	451	594	808	1278	1541	1895	2028	2204	2386	2558									
8	P <sub>GA</sub>	42.8	54.8	67.2	72.1	86.1	87.4	97.7	129	155	154	181	*	*	*	*									
	P <sub>GB</sub>	92.9	128	157	192	229	237	267	400	498	588	705	705	784	793	874									
	P <sub>GC</sub>	107	157	237	226	323	283	383	482	817	978	1185	1356	1531	1621	1793									
	P <sub>GD</sub>	152	225	324	336	459	419	541	719	1129	1375	1663	1830	2059	2174	2402									
9	P <sub>GA</sub>	41	52.7	64.5	70.2	82.7	85.8	95.3	129	162	159	193	169	176	*	*									
	P <sub>GB</sub>	87.8	121	148	182	215	226	251	383	490	565	699	684	730	774	823									
	P <sub>GC</sub>	98.8	144	218	212	297	267	352	454	791	914	1152	1283	1368	1542	1624									
	P <sub>GD</sub>	141	206	299	316	424	396	500	679	1094	1296	1625	1741	1853	2078	2188									
10	P <sub>GA</sub>	34.6	49.3	61.1	66.4	79.2	81.9	91.7	125	153	157	188	172	182	175	*									
	P <sub>GB</sub>	72.8	111	138	169	202	212	237	359	447	535	642	643	704	737	799									
	P <sub>GC</sub>	78.9	129	200	192	274	244	325	417	700	846	1018	1170	1296	1431	1546									
	P <sub>GD</sub>	112	185	276	288	392	363	462	626	972	1200	1444	1596	1760	1935	2085									
11.2	P <sub>GA</sub>	33.5	44.4	58.4	59.8	76.1	74.5	89	114	150	145	185	162	181	169	187									
	P <sub>GB</sub>	70.3	99.5	131	150	192	187	226	318	426	476	613	581	662	669	760									
	P <sub>GC</sub>	75.4	113	183	168	257	212	307	361	659	734	952	1030	1182	1267	1439									
	P <sub>GD</sub>	107	162	252	252	368	316	438	543	918	1046	1356	1411	1616	1720	1940									
12.5	P <sub>GA</sub>			54.5		72.2		85.1		145		183		175		186									
	P <sub>GB</sub>			119		179		212		400		579		598		691									
	P <sub>GC</sub>			163		234		280		604		882		1039		1276									
	P <sub>GD</sub>			225		337		401		845		1255		1430		1730									
14	P <sub>GA</sub>			49		65.2		77		131		168													
	P <sub>GB</sub>			106		159		189		353		514													
	P <sub>GC</sub>			142		205		243		522		763													
	P <sub>GD</sub>			196		293		348		733		1092													

\* Auf Anfrage

P<sub>GA</sub> (kW) Getriebe ohne Zusatzkühlung \*\*)

P<sub>GB</sub> (kW) Getriebe mit Lüfterkühlung \*\*)

P<sub>GC</sub> (kW) Getriebe mit eingebauter Kühlschlange \*\*) \*\*\*)

P<sub>GD</sub> (kW) Getriebe mit Lüfter und eingebauter Kühlschlange \*\*) \*\*\*)

\*\*) Werte gelten für:  
Einschaltdauer: 100 %  
Aufstellung in großer Halle  
Höhenlage bis 1000 m

\*\*\*) Werte gelten für eine Kühlwassereintrittstemperatur von 20 °C ohne Begrenzung der Kühlwasseraustrittstemperatur.  
Die Nachrechnung mit Begrenzung der Kühlwasseraustrittstemperatur ist auf Anfrage möglich.

\* On request

P<sub>GA</sub> (kW) Gear units without auxiliary cooling \*\*)

P<sub>GB</sub> (kW) Gear units with fan \*\*)

P<sub>GC</sub> (kW) Gear units with built-in cooling coil \*\*) \*\*\*)

P<sub>GD</sub> (kW) Gear units with fan and built-in cooling coil \*\*) \*\*\*)

\*\*) Values refer to:  
Operating cycle: 100 %  
Installation in a large hall  
Altitude up to 1000 m

\*\*\*) Values refer to a cooling water inlet temperature of 20 °C with unlimited cooling water outlet temperature.  
A recalculation with a limited cooling water outlet temperature is possible on request.

\* Sur demande

P<sub>GA</sub> (kW) Réducteurs sans refroidissement supplémentaire \*\*)

P<sub>GB</sub> (kW) Réducteurs avec ventilateur \*\*)

P<sub>GC</sub> (kW) Réducteurs avec serpentin intégré \*\*) \*\*\*)

P<sub>GD</sub> (kW) Réducteurs avec ventilateur et serpentin intégré \*\*) \*\*\*)

\*\*) Les valeurs sont valables pour:  
Durée d'utilisation: 100 %  
Implantation dans un grand hall  
Altitude jusqu'à 1000 m

\*\*\*) Les données sont valables pour une température d'eau de refroidissement en entrée de 20 °C sans limitation de la température de l'eau en sortie.  
Un calcul avec limitation de la température d'eau en sortie est possible sur demande.

## Zahnradgetriebe

Wärmegrenzleistungen

Bauart B2..

Größen 4 - 26

$n_1 = 1200 \text{ min}^{-1}$

## Gear Units

Thermal Capacities

Type B2..

Sizes 4 - 26

$n_1 = 1200 \text{ min}^{-1}$

## Réducteurs à engrenages

Capacités thermiques

Type B2..

Tailles 4 - 26

$n_1 = 1200 \text{ min}^{-1}$

Wärmegrenzleistungen P <sub>G</sub> (kW) / Thermal capacities P <sub>G</sub> (kW) / Capacités thermiques P <sub>G</sub> (kW)																									
i <sub>N</sub>		Getriebegrößen / Gear unit sizes / Tailles réducteurs																							
		4	5	6	7	8	9	10	11	12	13	14	15	16	17	18	19	20	21	22	23	24	25	26	
5	P <sub>GA</sub>	47.2	53.4		66		*		*		*		*												
	P <sub>GB</sub>	132	178		276		325		500		645		640												
	P <sub>GC</sub>	153	228		353		441		744		1467		1968												
	P <sub>GD</sub>	228	338		538		657		1085		1953		2390												
5.6	P <sub>GA</sub>	47.5	56.5		70.8		75.8		*		*		*		*										
	P <sub>GB</sub>	128	177		265		316		512		689		724		718										
	P <sub>GC</sub>	147	222		326		406		709		1414		1918		2224										
	P <sub>GD</sub>	221	330		501		614		1058		1950		2434		2726										
6.3	P <sub>GA</sub>	47.3	56.6	65.1	70.5	81.4	78.6	83.8	*	*	*	*	*	*	*										
	P <sub>GB</sub>	125	169	197	249	298	301	337	480	591	657	789	740	778	762										
	P <sub>GC</sub>	141	206	293	295	431	370	510	625	1076	1245	1551	1778	1944	2076										
	P <sub>GD</sub>	212	308	419	458	636	566	740	944	1500	1740	2150	2311	2499	2633										
7.1	P <sub>GA</sub>	45.8	56.4	67.5	71.4	83.8	82.4	89.8	108	*	*	*	*	*	*										
	P <sub>GB</sub>	117	161	194	237	285	288	325	485	598	683	817	762	809	811	849									
	P <sub>GC</sub>	129	190	286	272	397	340	468	604	1029	1211	1491	1655	1803	1954	2096									
	P <sub>GD</sub>	194	286	410	424	590	525	689	925	1451	1733	2124	2218	2394	2563	2723									
8	P <sub>GA</sub>	43.9	54.8	66.7	70.6	83	83	91.2	112	127	*	*	*	*	*	*									
	P <sub>GB</sub>	110	151	185	225	267	274	308	451	555	643	767	735	807	800	868									
	P <sub>GC</sub>	119	175	264	252	359	315	426	535	904	1081	1309	1493	1683	1780	1965									
	P <sub>GD</sub>	181	265	382	395	539	490	631	830	1293	1562	1884	2032	2273	2378	2608									
9	P <sub>GA</sub>	42.3	53.2	64.8	69.7	81.1	83.2	91.1	116	140	130	*	*	*	*	*									
	P <sub>GB</sub>	105	144	176	214	253	264	292	437	554	630	775	732	773	807	847									
	P <sub>GC</sub>	110	161	243	236	331	297	392	505	877	1013	1275	1415	1508	1697	1786									
	P <sub>GD</sub>	167	244	353	373	498	465	585	788	1261	1484	1857	1956	2073	2308	2414									
10	P <sub>GA</sub>	35.8	50.1	61.8	66.5	78.5	80.3	88.9	115	137	134	157	*	*	*	*									
	P <sub>GB</sub>	87.1	132	164	199	238	249	277	413	508	601	719	698	759	783	839									
	P <sub>GC</sub>	88.1	144	224	214	305	272	362	463	777	938	1129	1293	1431	1577	1703									
	P <sub>GD</sub>	134	219	326	340	462	426	542	729	1126	1381	1658	1806	1984	2167	2322									
11.2	P <sub>GA</sub>	34.8	45.3	59.3	60.2	75.9	73.6	87	106	136	127	160	*	*	*	*									
	P <sub>GB</sub>	84.3	118	155	177	227	220	265	367	488	539	691	637	720	720	809									
	P <sub>GC</sub>	84.2	126	204	187	286	236	341	401	733	814	1056	1139	1306	1399	1587									
	P <sub>GD</sub>	128	192	298	298	434	372	514	633	1066	1208	1563	1605	1831	1938	2175									
12.5	P <sub>GA</sub>			55.7		72.7		84.3		135		164		*		*									
	P <sub>GB</sub>			142		212		250		462		659		661		750									
	P <sub>GC</sub>			182		261		312		672		979		1150		1409									
	P <sub>GD</sub>			267		398		472		985		1454		1632		1957									
14	P <sub>GA</sub>			50.3		66.1		76.9		125		154													
	P <sub>GB</sub>			127		189		223		409		589													
	P <sub>GC</sub>			159		228		271		580		848													
	P <sub>GD</sub>			232		347		411		856		1270													

\* Auf Anfrage

P<sub>GA</sub> (kW) Getriebe ohne Zusatzkühlung \*\*)

P<sub>GB</sub> (kW) Getriebe mit Lüfterkühlung \*\*)

P<sub>GC</sub> (kW) Getriebe mit eingebauter Kühlschlange \*\*) \*\*\*)

P<sub>GD</sub> (kW) Getriebe mit Lüfter und eingebauter Kühlschlange \*\*) \*\*\*)

\*\*\*) Werte gelten für:  
Einschaltdauer: 100 %  
Aufstellung in großer Halle  
Höhenlage bis 1000 m

\*\*\*\*) Werte gelten für eine Kühlwassereintrittstemperatur von 20 °C ohne Begrenzung der Kühlwasseraustrittstemperatur.  
Die Nachrechnung mit Begrenzung der Kühlwasseraustrittstemperatur ist auf Anfrage möglich.

\* On request

P<sub>GA</sub> (kW) Gear units without auxiliary cooling \*\*)

P<sub>GB</sub> (kW) Gear units with fan \*\*)

P<sub>GC</sub> (kW) Gear units with built-in cooling coil \*\*) \*\*\*)

P<sub>GD</sub> (kW) Gear units with fan and built-in cooling coil \*\*) \*\*\*)

\*\*\*) Values refer to:  
Operating cycle: 100 %  
Installation in a large hall  
Altitude up to 1000 m

\*\*\*\*) Values refer to a cooling water inlet temperature of 20 °C with unlimited cooling water outlet temperature.  
A recalculation with a limited cooling water outlet temperature is possible on request.

\* Sur demande

P<sub>GA</sub> (kW) Réducteurs sans refroidissement supplémentaire \*\*)

P<sub>GB</sub> (kW) Réducteurs avec ventilateur \*\*)

P<sub>GC</sub> (kW) Réducteurs avec serpentin intégré \*\*) \*\*\*)

P<sub>GD</sub> (kW) Réducteurs avec ventilateur et serpentin intégré \*\*) \*\*\*)

\*\*\*) Les valeurs sont valables pour:  
Durée d'utilisation: 100 %  
Implantation dans un grand hall  
Altitude jusqu'à 1000 m

\*\*\*\*) Les données sont valables pour une température d'eau de refroidissement en entrée de 20 °C sans limitation de la température de l'eau en sortie.  
Un calcul avec limitation de la température d'eau en sortie est possible sur demande.

## Zahnradgetriebe

Wärmegrenzleistungen

Bauart B2..

Größen 4 - 26

$n_1 = 1500 \text{ min}^{-1}$

## Gear Units

Thermal Capacities

Type B2..

Sizes 4 - 26

$n_1 = 1500 \text{ min}^{-1}$

## Réducteurs à engrenages

Capacités thermiques

Type B2..

Tailles 4 - 26

$n_1 = 1500 \text{ min}^{-1}$

Wärmegrenzleistungen P <sub>G</sub> (kW) / Thermal capacities P <sub>G</sub> (kW) / Capacités thermiques P <sub>G</sub> (kW)																									
i <sub>N</sub>		Getriebegrößen / Gear unit sizes / Tailles réducteurs																							
		4	5	6	7	8	9	10	11	12	13	14	15	16	17	18	19	20	21	22	23	24	25	26	
5	P <sub>GA</sub>	35.3	*		*		*		*		*		*		*		*		*		*		*		*
	P <sub>GB</sub>	139	184		283		328		478		574		486												
	P <sub>GC</sub>	159	238		368		459		774		1524		2040												
	P <sub>GD</sub>	249	366		581		705		1144		2019		2386												
5.6	P <sub>GA</sub>	38.6	*		*		*		*		*		*		*		*		*		*		*		*
	P <sub>GB</sub>	135	185		274		322		504		646		618		565										
	P <sub>GC</sub>	154	231		340		424		738		1470		1992		2307										
	P <sub>GD</sub>	241	359		543		662		1126		2044		2489		2739										
6.3	P <sub>GA</sub>	40	*	*	*	*	*	*	*	*	*	*	*	*	*	*	*	*	*	*	*	*	*	*	*
	P <sub>GB</sub>	132	178	206	259	308	310	345	479	581	633	753	664	684	646										
	P <sub>GC</sub>	147	215	306	308	449	385	531	651	1120	1295	1613	1847	2019	2155										
	P <sub>GD</sub>	231	336	456	497	690	612	799	1010	1596	1839	2267	2393	2574	2689										
7.1	P <sub>GA</sub>	40.6	44	50.6	*	*	*	*	*	*	*	*	*	*	*	*	*	*	*	*	*	*	*	*	*
	P <sub>GB</sub>	125	169	204	248	298	299	336	493	601	676	804	720	754	740	760									
	P <sub>GC</sub>	135	199	298	284	414	354	488	629	1072	1261	1552	1722	1875	2031	2177									
	P <sub>GD</sub>	213	313	447	462	642	570	747	996	1556	1848	2261	2331	2505	2666	2817									
8	P <sub>GA</sub>	39.9	45.1	53.4	53	*	*	*	*	*	*	*	*	*	*	*	*	*	*	*	*	*	*	*	*
	P <sub>GB</sub>	117	160	195	236	280	287	321	463	564	646	768	713	775	756	808									
	P <sub>GC</sub>	124	182	276	263	375	328	444	557	942	1126	1364	1553	1751	1851	2043									
	P <sub>GD</sub>	198	290	417	430	586	533	686	896	1392	1674	2016	2152	2400	2499	2729									
9	P <sub>GA</sub>	39.3	45.7	54.4	55.8	61.6	59.6	*	*	*	*	*	*	*	*	*	*	*	*	*	*	*	*	*	*
	P <sub>GB</sub>	111	153	186	226	266	277	306	452	568	640	785	724	759	782	812									
	P <sub>GC</sub>	115	168	253	246	346	310	409	526	915	1055	1329	1474	1570	1766	1858									
	P <sub>GD</sub>	183	267	386	407	543	507	637	853	1363	1598	1996	2085	2204	2444	2549									
10	P <sub>GA</sub>	33.7	44	53.3	55.1	62.3	60.8	63.9	*	*	*	*	*	*	*	*	*	*	*	*	*	*	*	*	*
	P <sub>GB</sub>	92.8	140	174	211	251	261	291	429	525	616	734	698	753	770	818									
	P <sub>GC</sub>	91.9	150	233	224	318	284	377	483	810	978	1176	1347	1490	1642	1772									
	P <sub>GD</sub>	147	240	356	372	505	465	591	791	1218	1490	1787	1933	2118	2306	2464									
11.2	P <sub>GA</sub>	33	40.4	52.1	51	61.9	57.7	65.2	*	*	*	*	*	*	*	*	*	*	*	*	*	*	*	*	*
	P <sub>GB</sub>	89.8	125	165	188	240	232	279	382	506	555	709	641	721	714	797									
	P <sub>GC</sub>	87.9	131	213	195	298	246	356	418	764	849	1101	1186	1360	1457	1652									
	P <sub>GD</sub>	140	210	327	326	474	406	561	688	1156	1306	1688	1722	1960	2068	2315									
12.5	P <sub>GA</sub>			50.1		61.7		66.9		*		*		*		*		*		*		*		*	
	P <sub>GB</sub>			151		224		264		481		681		669		749									
	P <sub>GC</sub>			189		272		326		701		1021		1198		1468									
	P <sub>GD</sub>			292		435		515		1070		1574		1754		2093									
14	P <sub>GA</sub>			46		57.4		63.1		*		*													
	P <sub>GB</sub>			135		200		236		428		611													
	P <sub>GC</sub>			166		238		283		605		884													
	P <sub>GD</sub>			255		380		449		931		1377													

\* Auf Anfrage

P<sub>GA</sub> (kW) Getriebe ohne Zusatzkühlung \*\*)

P<sub>GB</sub> (kW) Getriebe mit Lüfterkühlung \*\*)

P<sub>GC</sub> (kW) Getriebe mit eingebauter Kühlschlange \*\*) \*\*\*)

P<sub>GD</sub> (kW) Getriebe mit Lüfter und eingebauter Kühlschlange \*\*) \*\*\*)

\*\*) Werte gelten für:  
Einschaltdauer: 100 %  
Aufstellung in großer Halle  
Höhenlage bis 1000 m

\*\*\*) Werte gelten für eine Kühlwassereintrittstemperatur von 20 °C ohne Begrenzung der Kühlwasseraustrittstemperatur.  
Die Nachrechnung mit Begrenzung der Kühlwasseraustrittstemperatur ist auf Anfrage möglich.

\* On request

P<sub>GA</sub> (kW) Gear units without auxiliary cooling \*\*)

P<sub>GB</sub> (kW) Gear units with fan \*\*)

P<sub>GC</sub> (kW) Gear units with built-in cooling coil \*\*) \*\*\*)

P<sub>GD</sub> (kW) Gear units with fan and built-in cooling coil \*\*) \*\*\*)

\*\*) Values refer to:  
Operating cycle: 100 %  
Installation in a large hall  
Altitude up to 1000 m

\*\*\*) Values refer to a cooling water inlet temperature of 20 °C with unlimited cooling water outlet temperature.  
A recalculation with a limited cooling water outlet temperature is possible on request.

\* Sur demande

P<sub>GA</sub> (kW) Réducteurs sans refroidissement supplémentaire \*\*)

P<sub>GB</sub> (kW) Réducteurs avec ventilateur \*\*)

P<sub>GC</sub> (kW) Réducteurs avec serpentin intégré \*\*) \*\*\*)

P<sub>GD</sub> (kW) Réducteurs avec ventilateur et serpentin intégré \*\*) \*\*\*)

\*\*) Les valeurs sont valables pour:  
Durée d'utilisation: 100 %  
Implantation dans un grand hall  
Altitude jusqu'à 1000 m

\*\*\*) Les données sont valables pour une température d'eau de refroidissement en entrée de 20 °C sans limitation de la température de l'eau en sortie.  
Un calcul avec limitation de la température d'eau en sortie est possible sur demande.

## Zahnradgetriebe

Wärmegrenzleistungen

Bauart B2..

Größen 4 - 26

$n_1 = 1800 \text{ min}^{-1}$

## Gear Units

Thermal Capacities

Type B2..

Sizes 4 - 26

$n_1 = 1800 \text{ min}^{-1}$

## Réducteurs à engrenages

Capacités thermiques

Type B2..

Tailles 4 - 26

$n_1 = 1800 \text{ min}^{-1}$

Wärmegrenzleistungen $P_G$ (kW) / Thermal capacities $P_G$ (kW) / Capacités thermiques $P_G$ (kW)																									
$i_N$		Getriebegrößen / Gear unit sizes / Tailles réducteurs																							
		4	5	6	7	8	9	10	11	12	13	14	15	16	17	18	19	20	21	22	23	24	25	26	
5	$P_{GA}$	*	*		*		*		*		*		*		*		*		*		*		*		*
	$P_{GB}$	149	190		283		313		392		350		*												
	$P_{GC}$	170	250		383		470		765		1446		1814												
	$P_{GD}$	276	401		630		753		1174		1966		2104												
5.6	$P_{GA}$	*	*		*		*		*		*		*		*		*		*		*		*		*
	$P_{GB}$	147	194		282		321		453		493		*		*										
	$P_{GC}$	164	244		356		439		744		1435		1851		2075										
	$P_{GD}$	268	395		593		716		1182		2066		2355		2464										
6.3	$P_{GA}$	31	*	*	*	*	*	*	*	*	*	*	*	*	*	*	*	*	*	*	*	*	*	*	*
	$P_{GB}$	144	189	218	270	318	315	346	450	519	528	612	419	*	*										
	$P_{GC}$	157	228	324	324	471	402	551	663	1127	1285	1592	1758	1902	1997										
	$P_{GD}$	258	371	504	546	754	666	865	1073	1673	1894	2322	2342	2482	2533										
7.1	$P_{GA}$	34	*	*	*	*	*	*	*	*	*	*	*	*	*	*	*	*	*	*	*	*	*	*	*
	$P_{GB}$	136	182	219	263	313	311	346	485	572	616	721	563	560	503	473									
	$P_{GC}$	145	212	317	301	437	372	512	650	1097	1275	1564	1687	1823	1951	2070									
	$P_{GD}$	238	347	495	511	707	625	817	1073	1659	1946	2371	2367	2519	2639	2751									
8	$P_{GA}$	35	*	*	*	*	*	*	*	*	*	*	*	*	*	*	*	*	*	*	*	*	*	*	*
	$P_{GB}$	129	173	211	253	298	302	336	467	556	616	723	609	641	592	600									
	$P_{GC}$	133	195	294	279	397	347	468	580	973	1152	1391	1549	1734	1815	1986									
	$P_{GD}$	222	323	464	477	649	588	754	973	1500	1785	2143	2230	2467	2539	2743									
9	$P_{GA}$	35	36	*	*	*	*	*	*	*	*	*	*	*	*	*	*	*	*	*	*	*	*	*	*
	$P_{GB}$	123	166	202	244	285	295	324	465	574	630	766	658	674	669	671									
	$P_{GC}$	123	180	271	263	368	329	433	551	952	1090	1369	1489	1578	1761	1839									
	$P_{GD}$	206	298	430	453	603	561	703	933	1480	1721	2144	2195	2306	2533	2619									
10	$P_{GA}$	31	36	43	*	*	*	*	*	*	*	*	*	*	*	*	*	*	*	*	*	*	*	*	*
	$P_{GB}$	102	154	190	229	271	280	310	447	537	617	729	655	694	688	712									
	$P_{GC}$	99	161	250	239	339	302	400	508	847	1015	1219	1373	1511	1653	1773									
	$P_{GD}$	164	268	398	414	561	516	654	868	1329	1614	1932	2052	2237	2416	2564									
11.2	$P_{GA}$	30	34	43	40	*	*	*	*	*	*	*	*	*	*	*	*	*	*	*	*	*	*	*	*
	$P_{GB}$	99	137	180	204	259	250	299	401	522	562	713	614	679	656	715									
	$P_{GC}$	94	141	229	209	319	262	379	441	801	885	1145	1215	1387	1476	1664									
	$P_{GD}$	157	235	365	363	528	451	622	757	1265	1420	1831	1839	2083	2183	2428									
12.5	$P_{GA}$			43		48		*		*		*		*		*		*		*		*		*	
	$P_{GB}$			166		244		284		503		697		650		701									
	$P_{GC}$			203		291		347		738		1068		1233		1494									
	$P_{GD}$			327		485		573		1176		1718		1882		2221									
14	$P_{GA}$			40		47		*		*		*		*		*		*		*		*		*	
	$P_{GB}$			149		218		255		451		633													
	$P_{GC}$			178		255		302		640		929													
	$P_{GD}$			285		424		500		1027		1509													

\* Auf Anfrage

$P_{GA}$  (kW) Getriebe ohne Zusatzkühlung \*\*)

$P_{GB}$  (kW) Getriebe mit Lüfterkühlung \*\*)

$P_{GC}$  (kW) Getriebe mit eingebauter Kühlschlange \*\*) \*\*\*)

$P_{GD}$  (kW) Getriebe mit Lüfter und eingebauter Kühlschlange \*\*) \*\*\*)

\*\*\*) Werte gelten für:  
Einschaltdauer: 100 %  
Aufstellung in großer Halle  
Höhenlage bis 1000 m

\*\*\*\*) Werte gelten für eine Kühlwassereintrittstemperatur von 20 °C ohne Begrenzung der Kühlwasseraustrittstemperatur.  
Die Nachrechnung mit Begrenzung der Kühlwasseraustrittstemperatur ist auf Anfrage möglich.

\* On request

$P_{GA}$  (kW) Gear units without auxiliary cooling \*\*)

$P_{GB}$  (kW) Gear units with fan \*\*)

$P_{GC}$  (kW) Gear units with built-in cooling coil \*\*) \*\*\*)

$P_{GD}$  (kW) Gear units with fan and built-in cooling coil \*\*) \*\*\*)

\*\*\*) Values refer to:  
Operating cycle: 100 %  
Installation in a large hall  
Altitude up to 1000 m

\*\*\*\*) Values refer to a cooling water inlet temperature of 20 °C with unlimited cooling water outlet temperature.  
A recalculation with a limited cooling water outlet temperature is possible on request.

\* Sur demande

$P_{GA}$  (kW) Réducteurs sans refroidissement supplémentaire \*\*)

$P_{GB}$  (kW) Réducteurs avec ventilateur \*\*)

$P_{GC}$  (kW) Réducteurs avec serpentin intégré \*\*) \*\*\*)

$P_{GD}$  (kW) Réducteurs avec ventilateur et serpentin intégré \*\*) \*\*\*)

\*\*\*) Les valeurs sont valables pour:  
Durée d'utilisation: 100 %  
Implantation dans un grand hall  
Altitude jusqu'à 1000 m

\*\*\*\*) Les données sont valables pour une température d'eau de refroidissement en entrée de 20 °C sans limitation de la température de l'eau en sortie.  
Un calcul avec limitation de la température d'eau en sortie est possible sur demande.

# Zahnradgetriebe

Nennleistungen  
Bauart B3..  
Größen 4 - 26

# Gear Units

Nominal Power Ratings  
Type B3..  
Sizes 4 - 26

# Réducteurs à engrenages

Puissances nominales  
Type B3..  
Tailles 4 - 26

Nennleistungen P <sub>2N</sub> (kW) / Nominal power ratings P <sub>2N</sub> (kW) / Puissances nominales P <sub>2N</sub> (kW)																									
i <sub>N</sub>	n <sub>1</sub>	n <sub>2</sub>	Getriebegrößen / Gear unit sizes / Tailles réducteurs																						
			4	5	6	7	8	9	10	11	12	13	14	15	16	17	18	19	20	21	22	23	24	25	26
12.5	1800	144	82	141		256		422		790		1198		1990*		2940*		3769*							
	1500	120	69	118		213		351		658		998		1658		2450		3141*		4272*					
	1200	96	55	94		170		281		526		799		1326		1960		2513*		3417*					
	1000	80	46	78		142		234		438		665		1105		1633		2094		2848					
14	1800	129	81	132		245		398		765		1102		1850*	1999*	2634*	3106*	3539*	3984*	4862*					
	1500	107	67	109		203		330		635		914		1534	1658	2184	2576	2935*	3305*	4033*	4537*				
	1200	86	54	88		163		265		510		734		1233	1332	1756	2071	2359*	2656*	3241*	3647*				
	1000	71	44	72		135		219		421		606		1018	1100	1449	1709	1947	2193	2676	3010				
16	1800	113	78	124	141	234	254	366	421	708	784	991	1176	1680*	1822*	2366*	2721*	3253*	3644*	4496*	4993*				
	1500	94	64	103	118	194	211	305	350	589	652	824	978	1397	1515	1968	2263	2706*	3031*	3740*	4153*				
	1200	75	51	82	94	155	168	243	279	470	520	658	780	1115	1209	1570	1806	2159*	2418*	2984*	3314*				
	1000	63	43	69	79	130	141	204	234	395	437	552	655	936	1015	1319	1517	1814	2031	2506	2783				
18	1800	100	70	118	131	220	241	354	392	649	727	907	1068	1549*	1675*	2094*	2513*	3015*	3350*	4188*	4586*				
	1500	83	58	98	109	183	200	294	325	538	604	753	886	1286	1390	1738	2085	2503*	2781*	3476*	3806*				
	1200	67	47	79	88	148	162	237	263	434	487	608	715	1038	1122	1403	1683	2020*	2245*	2806*	3072*				
	1000	56	39	66	73	123	135	198	219	363	407	508	598	867	938	1172	1407	1688	1876	2345	2568				
20	1800	90	63	109	124	204	235	336	370	598	685	854	989	1441*	1573*	1884*	2261*	2827*	3128*	3958*	4287*				
	1500	75	52	91	103	170	196	280	308	498	570	712	824	1201	1311	1570	1884	2356*	2607*	3298*	3573*	4397*			
	1200	60	42	72	82	136	157	224	246	398	456	569	659	961	1049	1256	1507	1884	2085*	2638	2858*	3518			
	1000	50	35	60	69	113	130	186	205	332	380	474	549	801	874	1047	1256	1570	1738	2198	2382	2931		4188*	
22.4	1800	80	56	97	118	181	221	299	350	531	633	759	904	1281*	1449*	1675*	2010*	2513*	2890*	3518*	3937*	4691*			
	1500	67	47	81	99	152	185	250	293	445	530	636	757	1073	1213	1403	1683	2104	2420*	2946*	3297*	3928*	4490*		
	1200	54	37	65	80	122	149	201	236	359	427	512	610	865	978	1130	1357	1696	1950	2367*	2657*	3166*	3618	4523*	
	1000	45	31	54	66	102	124	168	196	299	356	427	508	720	815	942	1130	1413	1625	1979	2214	2638	3015	3769*	4240*
25	1800	72	50	87	116	163	205	269	330	478	582	683	851	1153*	1304*	1507*	1809*	2261*	2601*	3166*	3543*	4221*	4825*		
	1500	60	42	72	97	136	170	224	275	398	485	569	709	961	1086	1256	1507	1884	2167	2638*	2952*	3518*	4020*		
	1200	48	33	58	77	109	136	179	220	319	388	455	567	769	869	1005	1206	1507	1734	2110*	2362*	2814*	3216*	4020*	4523*
	1000	40	28	48	64	90	113	149	183	265	323	379	473	640	724	837	1005	1256	1445	1759	1968	2345	2680	3350*	3769*
28	1800	64	44	77	103	145	182	239	293	425	517	607	757	1025*	1159*	1340*	1608*	2010*	2312*	2814*	3149*	3752*	4289*		
	1500	54	37	65	87	122	153	201	247	359	436	512	638	865	978	1130	1357	1696	1950	2374	2657*	3166*	3618*	4523*	
	1200	43	30	52	69	97	122	160	197	285	347	408	508	688	778	900	1080	1350	1553	1891	2116*	2521*	2881*	3602*	4052*
	1000	36	25	43	58	81	102	134	165	239	291	341	425	576	652	753	904	1130	1300	1583	1771	2110	2412	3015	3392*
31.5	1800	57	39	69	92	129	162	213	261	379	460	541	674	913*	1032*	1193*	1432*	1790*	2059*	2506*	2805*	3342*	3819*	4774*	
	1500	48	33	58	77	109	136	179	220	319	388	455	567	769	869	1005	1206	1507	1734	2110	2362	2814*	3216*	4020*	4523*
	1200	38	26	46	61	86	108	142	174	252	307	360	449	608	688	795	954	1193	1372	1671	1870	2228*	2546*	3183*	3581*
	1000	32	22	38	51	72	91	119	146	212	258	303	378	512	579	670	804	1005	1156	1407	1574	1876	2144	2680	3015
35.5	1800	51	35	61	82	115	145	190	233	339	412	484	603	817*	923*	1068*	1281*	1602*	1842*	2242*	2509*	2990*	3417*	4272*	4806*
	1500	42	29	51	68	95	119	157	192	279	339	398	496	672	760	879	1055	1319	1517	1847	2067	2462	2814*	3518*	3958*
	1200	34	23	41	55	77	96	127	155	226	274	322	402	544	615	712	854	1068	1228	1495	1673	1993	2278*	2848*	3204*
	1000	28	19	34	45	63	79	104	128	186	226	265	331	448	507	586	703	879	1011	1231	1378	1641	1876	2345	2638
40	1800	45	31	54	73	102	128	168	206	299	363	427	532	720*	815*	942*	1130*	1413*	1625*	1979*	2214*	2638*	3015*	3769*	4240*
	1500	38	26	46	61	86	108	142	174	252	307	360	449	608	688	795	954	1193	1372	1671	1870	2228	2546	3183*	3581*
	1200	30	21	36	48	68	85	112	137	199	242	284	354	480	543	628	753	942	1083	1319	1476	1759	2010	2513*	2827*
	1000	25	17	30	40	56	71	93	114	166	202	237	295	400	452	523	628	785	903	1099	1230	1465	1675	2094	2356
45	1800	40	28	48	64	90	113	149	183	265	323	379	473	640*	724*	837*	1005*	1256*	1445*	1759*	1968*	2345*	2680*	3350*	3769*
	1500	33	23	40	53	74	93	123	151	219	266	313	390	528	597	691	829	1036	1192	1451	1624	1935	2211	2764	3109*
	1200	27	18	32	43	61	76	100	123	179	218	256	319	432	489	565	678	848	975	1187	1328	1583	1809	2261	2544*
	1000	22	15	26	35	49	62	82	100	146	177	208	260	352	398	460	552	691	794	967	1082	1290	1474	1842	2073
50	1800	36	25	43	58	81	102	134	165	239	291	341	425	576	652*	753*	904*	1130*	1300*	1583*	1771*	2110*	2412*	3015*	3392*
	1500	30	21	36	48	68	85	112	137	199	242	284	354	480	543	628	753	942	1083	1319	1476	1759	2010	2513	2827
	1200	24	16	29	38	54	68	89	110	159	194	227	283	384	434	502	603	753	867	1055	1181	1407	1608	2010	2261
	1000	20	14	24	32	45	56	74	91	132	161	189	236	320	362	418	502	628	722	879	984	1172	1340	1675	1884
56	1800	32	22	38	51	72	91	119	146	212	258	303	378	512	579	670*	804*	1005*	1156*	1407*	1574*	1876*	2144*	2680*	3015*
	1500	27	18	32	43	61	76	100	123	179	218	256	319	432	489	565	678	848	975	1187	1328	1583	1809	2261	2544
	1200	21	14	25	34	47	59	78	96	139	169	199	248	336	380	439	527	659	758	923	1033	1231	1407	1759	1979
	1000	17.9	12	21	29	40	50	66	82	119	144	170	211	286	324	374	449	562	646	787	880	1049	1199	1499	1686
63	1800	29	20	34	47	64	82	108	133	192	234	275	343	464	525	607*	728*	910*	1047*	1275*	1427*	1700*	1943*	2429*	2732*
	1500	24	16	28	38	53	68	89	110	159	194	227	283	384	434	502	603	753	867	1055	1181	1407	1608	2010	2261
	1200	19	13	22	30	42	54	71	87	126	153	180	224	304	344	397									



### Zahnradgetriebe

Nenn-Abtriebsdrehmomente  
Bauart B3..  
Größen 4 - 26

### Gear Units

Nominal Output Torques  
Type B3..  
Sizes 4 - 26

### Réducteurs à engrenages

Couples nominaux de sortie  
Type B3..  
Tailles 4 - 26

Nenn-Abtriebsdrehmomente T <sub>2N</sub> (kNm) Nominal output torques T <sub>2N</sub> (kNm) / Couples nominaux de sortie T <sub>2N</sub> (kNm)																							
i <sub>N</sub>	Getriebegrößen / Gear unit sizes / Tailles réducteurs																						
	4	5	6	7	8	9	10	11	12	13	14	15	16	17	18	19	20	21	22	23	24	25	26
5	6.1	9.4		19		29.9		46		68.6		122											
5.6	6.2	9.4		19		29.9		48.1		69.6		122	135	195									
6.3	6.2	9.4	12	19	23.8	29.9	38	50.2	58.8	73.8	85.2	130	141	195									
7.1	6.2	9.4	12	19	23.8	29.9	38	50.2	60.0	75.9	87.3	132	145	195	230								
8	6.2	9.4	12	19	23.8	29.9	38	50.2	63.1	80	91.5	132	148	195	230								
9	6.2	9.4	12	19	23.8	29.9	38	50.2	63.1	81.1	94.6	132	148	195	230								
10	6.2	9.4	12	19	23.8	29.9	38	54	66.3	81.1	98.8	132	148	195	230								
11.2	6.2	9.4	12	19	23.8	29.9	38	54	66.3	81.1	101	132	148	195	230								
12.5	5.5	9.4	12	17	23.8	28	38	52.4	66.3	79.5	101	132	148	195	230	250		340					
14	6	9.8	12	18.2	23.8	29.5	38	56.7	66.3	81.6	101	137	148	195	230	262	295	360	405				
16	6.6	10.5	12	19.8	21.5	31	35.6	59.9	66.3	83.8	99.4	142	154	200	230	275	308	380	422				
18	6.7	11.3	12.6	21.1	23.1	33.9	37.5	62	69.5	86.7	102	148	160	200	240	288	320	400	438				
20	6.7	11.6	13.2	21.7	25	35.7	39.3	63.5	72.7	90.7	105	153	167	200	240	300	332	420	455	560		800	
22.4	6.7	11.6	14.2	21.7	26.5	35.7	41.8	63.5	75.6	90.7	108	153	173	200	240	300	345	420	470	560	640	800	900
25	6.7	11.6	15.5	21.7	27.2	35.7	43.8	63.5	77.2	90.7	113	153	173	200	240	300	345	420	470	560	640	800	900
28	6.7	11.6	15.5	21.7	27.2	35.7	43.8	63.5	77.2	90.7	113	153	173	200	240	300	345	420	470	560	640	800	900
31.5	6.7	11.6	15.5	21.7	27.2	35.7	43.8	63.5	77.2	90.7	113	153	173	200	240	300	345	420	470	560	640	800	900
35.5	6.7	11.6	15.5	21.7	27.2	35.7	43.8	63.5	77.2	90.7	113	153	173	200	240	300	345	420	470	560	640	800	900
40	6.7	11.6	15.5	21.7	27.2	35.7	43.8	63.5	77.2	90.7	113	153	173	200	240	300	345	420	470	560	640	800	900
45	6.7	11.6	15.5	21.7	27.2	35.7	43.8	63.5	77.2	90.7	113	153	173	200	240	300	345	420	470	560	640	800	900
50	6.7	11.6	15.5	21.7	27.2	35.7	43.8	63.5	77.2	90.7	113	153	173	200	240	300	345	420	470	560	640	800	900
56	6.7	11.6	15.5	21.7	27.2	35.7	43.8	63.5	77.2	90.7	113	153	173	200	240	300	345	420	470	560	640	800	900
63	6.6	11.4	15.5	21.4	27.2	35.7	43.8	63.5	77.2	90.7	113	153	173	200	240	300	345	420	470	560	640	800	900
71	6.6	11	15.5	20	27.2	34	43.8	60	77.2	90.7	113	153	173	200	240	300	345	420	470	560	640	800	900
80		11.6	14	21.7	26.9	35.7	43.8	61.6	77.2	90.7	113	153	173	200	240	300	345	420	470	560	640	800	900
90		11.6	14	21.7	25.2	35.7	43	61.6	75	90.7	113	153	173	200	240	300	345	420	470	560	640	800	900
100		11.6	15.5	21.7	27.2	35.7	44.2	61.6	78	90.7	113	153	173	200	240	300	345	420	470	560	640	800	900
112		11.6	15.5	21.7	27.2	35.7	44.2	61.6	78	90.7	113	153	173	200	240	300	345	420	470	560	640	800	900
125		11.6	15.5	21.7	27.2	35.7	44.2	61.6	78	90.7	113	153	173	200	240	300	345	420	470	560	640	800	900
140		11.6	15.5	21.7	27.2	35.7	44.2	61.6	78	90.7	113	153	173	200	240	300	345	420	470	560	640	800	900
160		11.6	15.5	21.7	27.2	35.7	44.2	61.6	78	90.7	113	153	173	200	240	300	345	420	470	560	640	800	900
180		11.6	15.5	21.7	27.2	35.7	44.2	61.6	78	90.7	113	153	173	200	240	300	345	420	470	560	640	800	900
200		11.6	15.5	21.7	27.2	35.7	44.2	61.6	78	90.7	113	153	173	200	240	300	345	420	470	560	640	800	900
224		11.6	15.5	21.7	27.2	35.7	44.2	61.6	78	90.7	113	153	173	200	240	300	345	420	470	560	640	800	900
250		11.6	15.5	21.7	27.2	35.7	44.2	61.6	78	90.7	113	153	173	200	240	300	345	420	470	560	640	800	900
280		11.6	15.5	21.7	27.2	35.3	44.2	61.6	78	90.7	113	153	173	200	240	300	345	420	470	560	640	800	900
315		11.2	15.5	20.5	27.2	34	44.2	60	78	90.7	113	153	173	200	240	300	345	420	470	560	640	800	900
355			15.5		26.5		44.2		78		113		173		240		345		470		640		900
400			14.5		25.5		43		75		113												

**B2**

siehe Seiten 38 - 43  
see pages 38 - 43  
voir pages 38 - 43

**B4**

siehe Seiten 50 - 53  
see pages 50 - 53  
voir pages 50 - 53

# Zahnradgetriebe

Wärmegrenzleistungen

Bauart B3..

Größen 4 - 26

$n_1 = 1000 \text{ min}^{-1}$

# Gear Units

Thermal Capacities

Type B3..

Sizes 4 - 26

$n_1 = 1000 \text{ min}^{-1}$

# Réducteurs à engrenages

Capacités thermiques

Type B3..

Tailles 4 - 26

$n_1 = 1000 \text{ min}^{-1}$

Wärmegrenzleistungen  $P_G$  (kW) / Thermal capacities  $P_G$  (kW) / Capacités thermiques  $P_G$  (kW)

$i_N$		Getriebegrößen / Gear unit sizes / Tailles réducteurs																									
		4	5	6	7	8	9	10	11	12	13	14	15	16	17	18	19	20	21	22	23	24	25	26			
12.5	$P_{GA}$	38.1	50.8		79.7		103		140		172		221		235		*		*								
	$P_{GB}$	66.3	93.9		150		204		321		419		583		742		*		*								
	$P_{GC}$	76.8	124		218		323		456		714		1117		1339		*		*								
	$P_{GD}$	100	161		280		413		613		923		1410		1745		*		*								
14	$P_{GA}$	37.1	49.4		77.4		101		139		177		220	233	235	259	*	*	*	*							
	$P_{GB}$	64.4	90.9		144		198		315		424		562	604	716	798	*	*	*	*							
	$P_{GC}$	74.5	119		210		313		447		719		1066	1129	1286	1410	*	*	*	*							
	$P_{GD}$	97.2	155		270		399		600		932		1349	1433	1677	1838	*	*	*	*							
16	$P_{GA}$	35.2	47.9	55.4	74	86.2	99.4	110	133	155	165	191	221	227	241	245	*	*	*	*							
	$P_{GB}$	61.3	87.5	100	137	158	193	214	300	347	388	448	553	579	713	732	*	*	*	*							
	$P_{GC}$	70.8	115	128	200	223	304	343	425	557	654	740	1043	1079	1265	1292	*	*	*	*							
	$P_{GD}$	92.2	149	165	257	285	388	434	569	724	846	959	1322	1366	1654	1682	*	*	*	*							
18	$P_{GA}$	34.3	46.5	53.7	71.7	83.2	96.5	102	132	156	167	195	216	230	237	263	*	*	*	*							
	$P_{GB}$	59.5	84.8	97.1	133	153	187	197	293	347	392	452	531	573	686	763	*	*	*	*							
	$P_{GC}$	68.5	111	122	192	217	293	315	416	558	658	745	1001	1063	1210	1332	*	*	*	*							
	$P_{GD}$	89.5	144	159	247	277	375	399	558	726	853	965	1265	1344	1584	1738	*	*	*	*							
20	$P_{GA}$	32.4	44.6	51.9	68.9	79.4	92.8	105	126	147	159	180	212	223	234	246	271	*	270	*	*	*	*	*	*		
	$P_{GB}$	56.1	81.3	93.5	127	145	179	203	280	323	367	413	513	548	662	700	814	*	899	*	*	*	*	*	*		
	$P_{GC}$	64.8	107	118	184	204	280	323	396	516	615	677	961	1010	1164	1214	*	*	*	*	*	*	*	*	*		
	$P_{GD}$	84.3	138	154	236	261	360	410	531	672	798	877	1215	1280	1523	1589	*	*	*	*	*	*	*	*	*		
22.4	$P_{GA}$	31.6	44	50.4	66.8	77.4	90.7	97.5	122	148	154	185	210	219	236	243	276	286	279	270	*	*	*	*	*		
	$P_{GB}$	54.6	80	90.7	123	141	175	186	266	324	349	417	498	528	646	675	795	833	881	907	*	*	*	*	*		
	$P_{GC}$	63	105	115	178	198	272	295	367	515	574	683	910	966	1114	1164	*	*	*	*	*	*	*	*	*		
	$P_{GD}$	82.2	137	149	226	253	348	375	495	671	746	885	1155	1227	1461	1525	*	*	*	*	*	*	*	*	*		
25	$P_{GA}$	30.1	41.8	48.6	65	74.7	87.3	94.3	117	144	149	176	204	222	234	250	281	297	292	291	*	*	*	*	*		
	$P_{GB}$	51.7	75.5	86.9	119	134	166	178	250	309	329	390	466	513	607	661	763	816	846	893	*	*	*	*	*		
	$P_{GC}$	59.4	99.4	110	169	189	253	284	337	489	527	638	823	919	1013	1116	*	*	*	*	*	*	*	*	*		
	$P_{GD}$	77.4	128	142	217	243	324	359	454	640	687	827	1047	1168	1333	1467	*	*	*	*	*	*	*	*	*		
28	$P_{GA}$	29	40.6	48	62.1	72.7	83.9	92.7	113	140	144	172	205	216	239	248	285	302	301	306	*	*	*	*	*		
	$P_{GB}$	49.4	72.7	85.5	112	130	157	174	238	295	312	373	453	480	596	621	731	782	811	857	*	*	*	*	*		
	$P_{GC}$	56	94	109	156	183	235	274	313	456	489	593	789	832	980	1015	*	*	*	*	*	*	*	*	*		
	$P_{GD}$	73.1	121	141	201	234	302	349	424	596	640	772	1007	1060	1292	1336	*	*	*	*	*	*	*	*	*		
31.5	$P_{GA}$	27.5	38.6	45.5	59.2	70.3	80.6	89.1	108	133	139	165	196	215	232	250	279	302	299	312	*	*	*	*	*		
	$P_{GB}$	46.8	68.7	80.6	106	125	149	165	225	276	296	350	423	468	557	608	688	749	759	821	*	*	*	*	*		
	$P_{GC}$	52.5	87.6	102	146	174	220	254	291	417	453	543	715	797	896	982	*	*	*	*	*	*	*	*	*		
	$P_{GD}$	68.6	113	133	188	222	282	324	395	548	595	710	917	1020	1184	1296	*	*	*	*	*	*	*	*	*		
35.5	$P_{GA}$	25.9	36.4	44	56.4	67	76.9	85.3	105	128	135	159	192	205	228	241	278	293	297	306	*	*	*	*	*		
	$P_{GB}$	43.8	64.3	77.5	100	119	141	156	215	262	284	332	407	435	538	569	666	703	731	767	*	*	*	*	*		
	$P_{GC}$	48.3	80.2	96.8	135	162	201	237	276	389	431	506	680	725	853	897	*	*	*	*	*	*	*	*	*		
	$P_{GD}$	63.1	104	126	174	207	260	302	373	509	566	662	873	929	1129	1188	*	*	*	*	*	*	*	*	*		
40	$P_{GA}$	22.6	31.7	41.8	49.4	64.1	72.1	81.6	99.6	122	128	152	183	199	220	236	267	289	287	302	*	*	*	*	*		
	$P_{GB}$	38.1	55.5	73.3	87.1	112	131	149	201	246	267	315	383	419	508	548	627	679	686	738	*	*	*	*	*		
	$P_{GC}$	40.7	66.7	90.4	112	151	182	222	253	360	397	471	627	687	793	853	*	*	*	*	*	*	*	*	*		
	$P_{GD}$	53.2	87	117	144	193	235	283	344	473	523	617	808	884	1053	1132	*	*	*	*	*	*	*	*	*		
45	$P_{GA}$	22.1	30.9	39.3	48	60.9	66.4	77.7	91.6	117	119	147	171	190	206	228	253	278	270	291	*	*	*	*	*		
	$P_{GB}$	37.2	54	68.5	84.1	106	120	140	184	236	244	301	352	395	470	520	582	638	634	692	*	*	*	*	*		
	$P_{GC}$	39.5	64.3	82.9	108	139	164	203	227	340	356	446	564	634	719	798	*	*	*	*	*	*	*	*	*		
	$P_{GD}$	51.8	84	107	139	179	211	260	311	449	467	586	728	818	955	1057	*	*	*	*	*	*	*	*	*		
50	$P_{GA}$	22.4	30.8	34.4	47.6	53.6	65.5	73.1	92.4	112	122	141	178	179	219	216	256	267	302	283	*	*	*	*	*		
	$P_{GB}$	37.4	53.3	59.4	82.5	92.5	117	131	181	221	244	283	356	363	478	481	561	595	668	641	*	*	*	*	*		
	$P_{GC}$	39.5	62.6	69.2	104	116	156	184	222	312	352	412	567	571	727	725	*	*	*	*	*	*	*	*	*		
	$P_{GD}$	51.6	81.9	90.3	134	149	203	236	301	411	466	543	728	738	962	963	*	*	*	*	*	*	*	*	*		
56	$P_{GA}$	20.7	28.5	33.6	44.3	52.1	60.7	67.7	84.5	103	113	131	165	186	205	228	251	268	294	312	*	*	*	*	*		
	$P_{GB}$	34.4	49.3	57.8	76.7	89.6	108	120	164	203	223	258	325	365	438	488	540	571	630	675	*	*	*	*	*		
	$P_{GC}$	35.6	56.4	66.7	94.7	111	140	166	197	279	315	366	507	573	654	729	*	*	*	*	*	*	*	*	*		
	$P_{GD}$	46.8	74.1	87.2	122	143	182	213	268	370	416	486	652	738	867	966	*	*	*	*	*	*	*	*	*		
63	$P_{GA}$	19.9	27.4	33.4	42.8	51.5	58.7	66.5	81.7	103	109	133	159	171	198	211	245	260	287	298	*	*	*	*	*		
	$P_{GB}$	33.1	47.3	57.1	74.1	88.1	104	117	158	198	214	259	309	333	419	447	520	549	608	633	*	*	*	*	*		
	$P_{GC}$	33.7	53.3	65	89.8	108	132	159	185	271	296	365	475	510	615	657	*	*	*	*	*	*	*	*	*		
	$P_{GD}$	44.3	70.1	85.1	116	140	173	203	253	358	393	481	612	659	820	869	*	*	*	*	*	*	*	*	*		
71	$P_{GA}$	18.4	26.1	30.8	40.8	47.8	55	61.7	75.7	94.8	103	122	151	164	187	204	232	252	272	291	*	*	*	*	*		
	$P_{GB}$	30.7	44.9	52.6	70.5	81.7	97.8	108	146	180	201	236	292	318	393												

# Zahnradgetriebe

Wärmegrenzleistungen

Bauart B3..

Größen 4 - 26

$n_1 = 1200 \text{ min}^{-1}$

# Gear Units

Thermal Capacities

Type B3..

Sizes 4 - 26

$n_1 = 1200 \text{ min}^{-1}$

# Réducteurs à engrenages

Capacités thermiques

Type B3..

Tailles 4 - 26

$n_1 = 1200 \text{ min}^{-1}$

		Wärmegrenzleistungen $P_G$ (kW) / Thermal capacities $P_G$ (kW) / Capacités thermiques $P_G$ (kW)																						
$i_N$		Getriebegrößen / Gear unit sizes / Tailles réducteurs																						
		4	5	6	7	8	9	10	11	12	13	14	15	16	17	18	19	20	21	22	23	24	25	26
12.5	$P_{GA}$	39.7	52.1		80.7		103		132		152		173		*		*		*					
	$P_{GB}$	75.6	106		169		230		356		457		620		777		*		*					
	$P_{GC}$	85.5	138		243		359		508		795		1243		1491		*		*					
	$P_{GD}$	115	184		321		472		697		1042		1577		1939		*		*					
14	$P_{GA}$	38.8	51		79		101		134		161		181	186	*	*	*	*	*	*	*	*	*	*
	$P_{GB}$	73.5	103		163		223		350		465		603	645	758	838	*	*	*	*	*	*	*	*
	$P_{GC}$	82.9	133		234		349		497		801		1187	1257	1432	1570	*	*	*	*	*	*	*	*
	$P_{GD}$	111	178		309		457		683		1054		1513	1605	1871	2046	*	*	*	*	*	*	*	*
16	$P_{GA}$	37	49.5	57	75.7	87.5	100	110	129	147	151	174	185	186	189	*	*	*	*	*	*	*	*	*
	$P_{GB}$	70	99.5	113	156	178	218	240	334	384	426	492	597	621	758	774	*	*	*	*	*	*	*	*
	$P_{GC}$	78.8	128	142	223	248	338	382	473	620	728	824	1161	1201	1408	1438	*	*	*	*	*	*	*	*
	$P_{GD}$	105	171	190	294	326	444	496	648	823	958	1085	1486	1532	1849	1876	*	*	*	*	*	*	*	*
18	$P_{GA}$	36	48.1	55.5	73.6	84.8	97.7	102	129	149	155	180	185	193	191	205	*	*	*	*	*	*	*	*
	$P_{GB}$	67.9	96.5	110	151	173	211	222	328	386	432	498	575	617	734	811	*	*	*	*	*	*	*	*
	$P_{GC}$	76.3	123	136	214	241	326	351	463	621	732	829	1115	1183	1347	1483	*	*	*	*	*	*	*	*
	$P_{GD}$	102	166	183	284	317	429	457	635	825	967	1093	1424	1510	1775	1942	*	*	*	*	*	*	*	*
20	$P_{GA}$	34	46.4	53.7	70.9	81.2	94.3	106	124	141	149	168	185	191	194	198	211	*	*	*	*	*	*	*
	$P_{GB}$	64.1	92.6	106	145	165	202	228	314	360	406	456	557	593	711	749	865	*	*	*	*	*	*	*
	$P_{GC}$	72.2	119	132	205	227	312	359	441	574	685	754	1070	1124	1296	1352	*	*	*	*	*	*	*	*
	$P_{GD}$	96.9	159	176	270	300	412	469	605	764	905	995	1370	1440	1710	1780	*	*	*	*	*	*	*	*
22.4	$P_{GA}$	33.3	45.8	52.3	68.9	79.4	92.5	98.9	120	144	147	174	187	192	201	202	222	226	*	*	*	*	*	*
	$P_{GB}$	62.4	91.1	103	140	160	198	210	298	361	387	462	544	574	698	725	850	888	910	920	*	*	*	*
	$P_{GC}$	70.2	117	128	198	220	303	329	409	573	639	761	1013	1076	1240	1296	*	*	*	*	*	*	*	*
	$P_{GD}$	94.5	158	171	260	290	399	429	565	764	847	1005	1304	1383	1644	1712	*	*	*	*	*	*	*	*
25	$P_{GA}$	31.8	43.7	50.6	67.4	77.1	89.7	96.4	117	142	144	170	189	202	208	219	241	250	*	*	*	*	*	*
	$P_{GB}$	59.1	86.2	99	135	153	188	202	281	346	367	435	513	563	662	718	826	880	889	926	*	*	*	*
	$P_{GC}$	66.1	110	122	188	211	282	316	375	545	587	710	916	1023	1128	1242	*	*	*	*	*	*	*	*
	$P_{GD}$	89	147	163	249	279	371	411	519	730	783	941	1186	1322	1505	1654	*	*	*	*	*	*	*	*
28	$P_{GA}$	30.7	42.6	50.3	64.8	75.5	86.8	95.6	114	140	143	170	195	204	222	227	257	269	244	*	*	*	*	*
	$P_{GB}$	56.6	83	97.5	127	148	179	197	269	332	350	417	503	531	656	682	800	854	868	906	*	*	*	*
	$P_{GC}$	62.4	104	121	174	204	261	305	349	508	545	660	879	926	1091	1130	*	*	*	*	*	*	*	*
	$P_{GD}$	84.2	139	162	231	268	346	400	486	682	731	881	1145	1204	1465	1513	*	*	*	*	*	*	*	*
31.5	$P_{GA}$	29.1	40.6	47.8	62	73.4	83.9	92.4	111	135	140	165	191	208	221	236	260	279	257	256	*	*	*	*
	$P_{GB}$	53.7	78.5	92.1	121	143	170	188	254	312	333	393	473	521	619	673	760	824	822	881	*	*	*	*
	$P_{GC}$	58.5	97.5	114	162	194	245	283	324	464	505	605	796	887	998	1093	*	*	*	*	*	*	*	*
	$P_{GD}$	78.9	130	153	216	255	324	372	453	627	680	811	1044	1161	1345	1471	*	*	*	*	*	*	*	*
35.5	$P_{GA}$	27.5	38.4	46.3	59.2	70.2	80.3	88.8	108	131	137	160	189	201	221	232	265	277	265	263	*	*	*	*
	$P_{GB}$	50.2	73.6	88.6	114	136	161	178	244	296	321	375	457	487	599	633	739	779	798	830	*	*	*	*
	$P_{GC}$	53.8	89.3	107	151	180	224	264	307	433	480	564	757	807	949	999	*	*	*	*	*	*	*	*
	$P_{GD}$	72.7	120	144	200	238	298	347	428	584	648	758	996	1059	1286	1351	*	*	*	*	*	*	*	*
40	$P_{GA}$	24	33.5	44.1	52	67.3	75.4	85.2	102	125	130	155	182	197	215	230	258	277	262	266	*	*	*	*
	$P_{GB}$	43.7	63.5	83.8	99.6	128	150	170	229	279	302	355	430	470	568	611	698	754	753	804	*	*	*	*
	$P_{GC}$	45.3	74.3	100	125	168	202	247	282	401	442	525	698	765	883	949	*	*	*	*	*	*	*	*
	$P_{GD}$	61.3	100	135	166	222	270	325	395	542	599	706	923	1009	1200	1289	*	*	*	*	*	*	*	*
45	$P_{GA}$	23.5	32.7	41.5	50.6	64	69.6	81.3	95	121	122	150	171	189	204	224	247	270	251	263	*	*	*	*
	$P_{GB}$	42.6	61.8	78.4	96.1	121	137	160	210	268	276	341	397	444	526	581	650	712	698	758	*	*	*	*
	$P_{GC}$	44	71.6	92.3	120	155	182	226	253	378	396	496	628	706	801	888	*	*	*	*	*	*	*	*
	$P_{GD}$	59.7	96.7	124	159	205	243	299	357	515	535	671	832	934	1090	1205	*	*	*	*	*	*	*	*
50	$P_{GA}$	23.8	32.7	36.4	50.3	56.6	69.1	77	96.6	116	126	146	182	182	221	218	257	266	293	269	*	*	*	*
	$P_{GB}$	42.9	61.1	68	94.5	105	133	150	207	251	278	321	402	411	539	542	631	669	744	712	*	*	*	*
	$P_{GC}$	44	69.7	77	116	129	174	205	247	348	392	459	631	636	809	807	*	*	*	*	*	*	*	*
	$P_{GD}$	59.4	94.3	103	154	172	234	272	346	472	535	623	834	845	1101	1101	*	*	*	*	*	*	*	*
56	$P_{GA}$	22	30.2	35.7	47	55.2	64.3	71.5	88.9	108	118	136	171	191	210	233	256	272	293	307	*	*	*	*
	$P_{GB}$	39.4	56.5	66.3	87.9	102	124	137	188	232	254	294	369	415	497	553	611	645	708	755	*	*	*	*
	$P_{GC}$	39.6	62.8	74.3	105	123	156	185	219	311	351	408	565	638	728	811	*	*	*	*	*	*	*	*
	$P_{GD}$	53.9	85.4	100	141	165	210	245	308	426	478	558	748	846	994	1107	*	*	*	*	*	*	*	*
63	$P_{GA}$	21.2	29.1	35.5	45.5	54.6	62.2	70.4	86.1	108	114	139	165	177	204	217	251	266	289	297	*	*	*	*
	$P_{GB}$	38	54.3	65.5	84.9	100	119	134	180	227	244	296	352	378	475	507	589	622	686	712	*	*	*	*
	$P_{GC}$	37.5	59.3	72.4	100	120	147	177	206	302	330	407	529	568	685	731	*	*	*	*	*	*	*	*
	$P_{GD}$	51	80.8	98	134	161	199	234	291	411	452	553	703	757	941	997	*	*	*	*	*	*	*	*
71	$P_{GA}$	19.6	27.7	32.8	43.3	50.8	58.3	65.3	79.9	99.8	108	128	158	170	194	210	239	259	275	292	*	*	*	*
	$P_{GB}$	35.3	51.6	60.3	80.9	93.6	112	124	167	206	229	269	333	362	446	484	553	600	643	689	*	*	*	*
	$P_{GC}$	34.1	54.9	65.4	92.5	109	133	159	185	267	298	364	487	535	633	690	*	*	*	*	*	*	*	*
	$P_{GD}$	46.6																						

# Zahnradgetriebe

Wärmegrenzleistungen

Bauart B3..

Größen 4 - 26

$n_1 = 1500 \text{ min}^{-1}$

# Gear Units

Thermal Capacities

Type B3..

Sizes 4 - 26

$n_1 = 1500 \text{ min}^{-1}$

# Réducteurs à engrenages

Capacités thermiques

Type B3..

Tailles 4 - 26

$n_1 = 1500 \text{ min}^{-1}$

Wärmegrenzleistungen  $P_G$  (kW) / Thermal capacities  $P_G$  (kW) / Capacités thermiques  $P_G$  (kW)

$i_N$		Getriebegrößen / Gear unit sizes / Tailles réducteurs																									
		4	5	6	7	8	9	10	11	12	13	14	15	16	17	18	19	20	21	22	23	24	25	26			
12.5	$P_{GA}$	39.4	50.4		76.7		95.4		112		*		*		*		*		*		*		*		*		
	$P_{GB}$	84.8	118		186		250		377		468		602		728		*		*		*		*		*		
	$P_{GC}$	94.7	151		265		390		542		831		1261		1484		*		*		*		*		*		
	$P_{GD}$	131	209		362		529		768		1126		1652		1991		*		*		*		*		*		
14	$P_{GA}$	38.6	49.6		75.7		95.2		117		127		*		*		*		*		*		*		*		
	$P_{GB}$	82.6	114		180		244		374		482		598	631	728	792	*	*	*	*	*	*	*	*	*		
	$P_{GC}$	91.9	146		257		380		533		843		1217	1280	1443	1569	*	*	*	*	*	*	*	*	*		
	$P_{GD}$	127	202		350		514		756		1147		1603	1688	1947	2110	*	*	*	*	*	*	*	*	*		
16	$P_{GA}$	36.8	48.3	55.4	72.9	83.3	94.3	103	114	125	122	138	*	*	*	*	*	*	*	*	*	*	*	*	*		
	$P_{GB}$	78.6	110	126	172	196	239	262	358	407	445	511	597	615	737	741	*	*	*	*	*	*	*	*	*		
	$P_{GC}$	87.4	141	157	244	272	369	415	508	662	769	868	1196	1230	1429	1447	*	*	*	*	*	*	*	*	*		
	$P_{GD}$	121	195	216	334	369	500	558	719	907	1047	1181	1583	1621	1937	1949	*	*	*	*	*	*	*	*	*		
18	$P_{GA}$	35.9	47.2	54.1	71.1	81.1	92.5	96.3	115	129	128	146	*	*	*	*	*	*	*	*	*	*	*	*	*		
	$P_{GB}$	76.4	107	122	167	191	232	243	353	411	454	520	581	617	722	787	*	*	*	*	*	*	*	*	*		
	$P_{GC}$	84.7	136	150	235	265	357	383	499	665	777	877	1155	1219	1375	1503	*	*	*	*	*	*	*	*	*		
	$P_{GD}$	117	189	208	322	359	485	514	707	913	1060	1195	1525	1608	1872	2033	*	*	*	*	*	*	*	*	*		
20	$P_{GA}$	34	45.6	52.6	68.8	78	89.8	100	112	124	126	140	*	*	*	*	*	*	*	*	*	*	*	*	*		
	$P_{GB}$	72.1	103	118	161	182	223	251	339	385	428	480	568	599	708	736	839	*	*	*	*	*	*	*	*		
	$P_{GC}$	80.1	131	145	225	249	342	392	476	616	729	800	1114	1165	1332	1379	*	*	*	*	*	*	*	*	*		
	$P_{GD}$	111	181	201	307	340	466	529	676	848	996	1092	1475	1542	1815	1876	*	*	*	*	*	*	*	*	*		
22.4	$P_{GD}$	33.3	45.1	51.4	67.2	76.7	88.6	93.9	110	128	126	148	*	*	*	*	*	*	*	*	*	*	*	*	*		
	$P_{GB}$	70.3	101	115	155	177	218	231	324	388	412	489	559	586	702	722	836	864	824	793	*	*	*	*	*		
	$P_{GC}$	77.9	130	142	218	242	332	360	443	617	683	811	1061	1121	1282	1332	*	*	*	*	*	*	*	*	*		
	$P_{GD}$	108	180	195	296	330	452	485	632	850	936	1107	1412	1490	1756	1818	*	*	*	*	*	*	*	*	*		
25	$P_{GA}$	31.9	43.3	50.1	66.2	75.2	86.9	92.8	109	130	128	150	153	160	*	*	*	*	*	*	*	*	*	*	*		
	$P_{GB}$	66.7	96.6	110	151	170	209	223	307	375	395	466	537	585	681	732	833	881	841	844	*	*	*	*	*		
	$P_{GC}$	73.6	122	135	208	232	310	347	408	590	632	762	970	1078	1181	1294	*	*	*	*	*	*	*	*	*		
	$P_{GD}$	102	168	186	284	317	422	466	584	817	870	1045	1297	1440	1629	1780	*	*	*	*	*	*	*	*	*		
28	$P_{GA}$	30.9	42.5	50	64.1	74.4	85	93.1	109	131	131	155	168	172	183	182	200	*	*	*	*	*	*	*	*		
	$P_{GB}$	63.9	93.3	109	143	165	199	220	296	363	380	452	535	562	689	711	828	878	855	869	*	*	*	*	*		
	$P_{GC}$	69.4	116	134	193	225	288	336	382	554	590	715	939	987	1157	1193	*	*	*	*	*	*	*	*	*		
	$P_{GD}$	96.7	159	185	264	306	395	455	549	767	819	985	1265	1326	1605	1650	*	*	*	*	*	*	*	*	*		
31.5	$P_{GA}$	29.4	40.7	47.8	61.7	72.7	82.7	90.7	106	129	131	154	170	183	190	199	216	227	*	*	*	*	*	*	*		
	$P_{GB}$	60.7	88.5	103	136	160	190	210	282	344	365	430	508	558	658	712	799	863	831	871	*	*	*	*	*		
	$P_{GC}$	65.2	108	126	180	215	271	312	356	508	550	658	857	952	1067	1165	*	*	*	*	*	*	*	*	*		
	$P_{GD}$	90.8	149	175	247	292	370	424	514	709	766	912	1162	1288	1487	1620	*	*	*	*	*	*	*	*	*		
35.5	$P_{GA}$	27.8	38.6	46.4	59.1	69.8	79.6	87.7	105	125	130	151	173	181	196	203	228	235	*	*	*	*	*	*	*		
	$P_{GB}$	56.8	83	99.8	129	152	181	199	271	328	353	412	495	526	644	677	786	825	821	839	*	*	*	*	*		
	$P_{GC}$	59.9	99.3	119	167	200	248	292	338	475	524	615	819	871	1021	1071	*	*	*	*	*	*	*	*	*		
	$P_{GD}$	83.7	138	166	229	272	341	396	487	661	732	855	1114	1181	1429	1498	*	*	*	*	*	*	*	*	*		
40	$P_{GA}$	24.3	33.7	44.3	52	67.1	75	84.4	100	121	125	147	168	180	194	204	226	240	208	*	*	*	*	*	*		
	$P_{GB}$	49.4	71.6	94.6	112	144	168	191	255	310	334	392	469	510	614	657	747	805	783	822	*	*	*	*	*		
	$P_{GC}$	50.5	82.7	111	138	187	224	274	310	440	484	574	758	829	954	1022	*	*	*	*	*	*	*	*	*		
	$P_{GD}$	70.6	115	155	191	254	309	372	449	616	678	798	1035	1129	1339	1434	*	*	*	*	*	*	*	*	*		
45	$P_{GA}$	23.8	32.9	41.8	50.8	64	69.4	80.8	93.2	118	117	144	160	176	187	203	221	240	207	206	*	*	*	*	*		
	$P_{GB}$	48.3	69.8	88.5	108	137	154	180	234	298	306	377	434	484	572	629	700	765	733	785	*	*	*	*	*		
	$P_{GC}$	49	79.7	102	133	172	202	251	280	417	435	544	684	768	868	960	*	*	*	*	*	*	*	*	*		
	$P_{GD}$	68.7	111	142	183	236	279	342	407	585	607	760	936	1049	1221	1346	*	*	*	*	*	*	*	*	*		
50	$P_{GA}$	24.2	33	36.8	50.7	56.9	69.3	77	95.8	115	124	142	174	174	210	204	240	247	260	232	*	*	*	*	*		
	$P_{GB}$	48.7	69.2	76.9	106	119	151	169	232	281	310	358	445	453	593	594	690	730	799	757	*	*	*	*	*		
	$P_{GC}$	49.1	77.7	85.8	129	144	194	228	274	384	433	506	692	696	884	880	*	*	*	*	*	*	*	*	*		
	$P_{GD}$	68.5	108	119	177	197	269	312	396	539	610	709	944	956	1242	1240	*	*	*	*	*	*	*	*	*		
56	$P_{GA}$	22.4	30.7	36.2	47.5	55.7	64.8	72	88.9	108	117	135	167	186	203	225	245	260	271	279	*	*	*	*	*		
	$P_{GB}$	44.8	64	75.1	99.5	116	140	155	211	260	285	330	411	461	552	612	675	712	772	818	*	*	*	*	*		
	$P_{GC}$	44.2	70.1	82.9	117	138	174	206	243	345	389	451	622	702	800	891	*	*	*	*	*	*	*	*	*		
	$P_{GD}$	62.1	98.3	115	162	190	241	281	354	488	547	637	852	962	1128	1255	*	*	*	*	*	*	*	*	*		
63	$P_{GA}$	21.6	29.5	36	46.1	55.2	62.8	71	86.3	108	114	138	162	173	199	211	243	256	272	275	*	*	*	*	*		
	$P_{GB}$	43.2	61.6	74.2	96.2	114	135	151	203	255	275	332	393	422	529	563	654	689	752	776	*	*	*	*	*		
	$P_{GC}$	41.9	66.2	80.8	111	134	164	197	229	335	366	451	585	627	755	805	*	*	*	*	*	*	*	*	*		
	$P_{GD}$	58.9	93	112	154	185	229	269	334	471	517	633	802	862	1071	1133	*	*	*	*	*	*	*	*	*		
71	$P_{GA}$	20	28.2	33.3	43.9	51.4	59	65.9	80.2	99.9	107	127	155	167	190	205	232	251	261	273	*	*	*	*	*		
	$P_{GB}$	40	58.5	68.4	91.7	106	126	140	189	232	258	302	372	404	498	539	615	666	707	754	*	*	*	*	*		
	$P_{GC}$	38	61.3	73	103	122	148</																				

# Zahnradgetriebe

Wärmegrenzleistungen

Bauart B3..

Größen 4 - 26

$n_1 = 1800 \text{ min}^{-1}$

# Gear Units

Thermal Capacities

Type B3..

Sizes 4 - 26

$n_1 = 1800 \text{ min}^{-1}$

# Réducteurs à engrenages

Capacités thermiques

Type B3..

Tailles 4 - 26

$n_1 = 1800 \text{ min}^{-1}$

Wärmegrenzleistungen P <sub>G</sub> (kW) / Thermal capacities P <sub>G</sub> (kW) / Capacités thermiques P <sub>G</sub> (kW)																								
i <sub>N</sub>		Getriebegrößen / Gear unit sizes / Tailles réducteurs																						
		4	5	6	7	8	9	10	11	12	13	14	15	16	17	18	19	20	21	22	23	24	25	26
12.5	P <sub>GA</sub>	39	48		70.4		82.9		*		*		*		*		*		*		*		*	
	P <sub>GB</sub>	93.5	128		201		267		388		461		548		622		*		*		*		*	
	P <sub>GC</sub>	103	165		288		420		574		863		1271		1465		*		*		*		*	
	P <sub>GD</sub>	148	234		403		585		835		1199		1704		2009		*		*		*		*	
14	P <sub>GA</sub>	38.4	47.7		70.6		84.9		*		*		*		*		*		*		*		*	
	P <sub>GB</sub>	91.2	125		196		262		390		483		561	581	650	687	*	*	*	*	*	*	*	*
	P <sub>GC</sub>	100	160		279		410		568		882		1240	1296	1445	1556	*	*	*	*	*	*	*	*
	P <sub>GD</sub>	143	226		390		570		826		1231		1674	1750	1996	2141	*	*	*	*	*	*	*	*
16	P <sub>GA</sub>	36.8	46.7	53.1	68.5	76.8	85.1	90.8	89.8	*	*	*	*	*	*	*	*	*	*	*	*	*	*	*
	P <sub>GB</sub>	86.9	121	138	187	212	258	281	375	419	450	513	568	575	671	658	*	*	*	*	*	*	*	*
	P <sub>GC</sub>	95.9	154	171	266	295	399	448	542	701	807	909	1226	1252	1440	1446	*	*	*	*	*	*	*	*
	P <sub>GD</sub>	136	218	241	372	410	555	618	787	986	1128	1268	1662	1691	2000	1994	*	*	*	*	*	*	*	*
18	P <sub>GA</sub>	35.9	45.9	52.2	67.4	75.5	84.4	86.1	93.1	*	*	*	*	*	*	*	*	*	*	*	*	*	*	*
	P <sub>GB</sub>	84.5	118	134	182	207	250	261	371	426	462	527	560	586	669	714	*	*	*	*	*	*	*	*
	P <sub>GC</sub>	93	149	164	256	287	386	414	534	706	819	921	1190	1248	1395	1513	*	*	*	*	*	*	*	*
	P <sub>GD</sub>	132	212	233	360	400	539	570	776	995	1146	1289	1610	1687	1946	2096	*	*	*	*	*	*	*	*
20	P <sub>GA</sub>	34.1	44.5	51	65.7	73.3	82.9	90.8	93.3	96	*	*	*	*	*	*	*	*	*	*	*	*	*	*
	P <sub>GB</sub>	79.9	113	129	175	198	241	270	358	401	440	489	555	577	668	681	761	*	*	*	*	*	*	*
	P <sub>GC</sub>	88	143	159	246	271	371	425	511	657	771	844	1154	1199	1360	1399	*	*	*	*	*	*	*	*
	P <sub>GD</sub>	125	203	225	344	379	519	588	743	926	1081	1182	1566	1628	1900	1949	*	*	*	*	*	*	*	*
22.4	P <sub>GA</sub>	33.6	44.3	50.1	64.6	72.7	82.7	86.2	93.7	102	*	*	*	*	*	*	*	*	*	*	*	*	*	*
	P <sub>GB</sub>	77.9	112	126	170	193	237	250	343	407	426	503	554	573	673	681	774	789	661	576	*	*	*	*
	P <sub>GC</sub>	85.7	142	155	238	263	361	390	476	659	725	858	1104	1161	1318	1360	*	*	*	*	*	*	*	*
	P <sub>GD</sub>	122	202	219	331	368	504	539	697	932	1019	1203	1507	1582	1851	1902	*	*	*	*	*	*	*	*
25	P <sub>GA</sub>	32.3	43	49.4	64.6	72.5	82.8	87.2	97.2	110	102	116	*	*	*	*	*	*	*	*	*	*	*	*
	P <sub>GB</sub>	74.1	106	122	165	186	228	243	329	398	414	486	544	587	674	714	803	840	732	688	*	*	*	*
	P <sub>GC</sub>	80.9	134	148	227	254	337	377	440	634	675	813	1020	1128	1229	1339	*	*	*	*	*	*	*	*
	P <sub>GD</sub>	115	189	209	319	355	471	520	647	901	954	1143	1399	1546	1738	1890	*	*	*	*	*	*	*	*
28	P <sub>GA</sub>	31.4	42.6	49.9	63.4	72.9	82.5	89.4	100	117	112	130	*	*	*	*	*	*	*	*	*	*	*	*
	P <sub>GB</sub>	71.1	103	121	157	182	218	240	320	390	404	479	554	577	700	716	826	869	794	773	*	*	*	*
	P <sub>GC</sub>	76.5	127	147	211	246	315	367	414	598	635	767	998	1044	1218	1251	*	*	*	*	*	*	*	*
	P <sub>GD</sub>	109	179	209	296	344	442	509	611	851	903	1085	1378	1440	1734	1776	*	*	*	*	*	*	*	*
31.5	P <sub>GA</sub>	30.1	41	48	61.6	72	81.3	88.4	100	118	116	135	137	142	*	*	*	*	*	*	*	*	*	*
	P <sub>GB</sub>	67.6	98.1	114	150	177	209	230	306	371	391	460	534	582	681	731	814	874	802	815	*	*	*	*
	P <sub>GC</sub>	71.8	119	139	198	236	297	341	387	551	594	710	916	1015	1133	1233	*	*	*	*	*	*	*	*
	P <sub>GD</sub>	102	169	197	278	328	415	476	573	788	849	1009	1274	1409	1619	1759	*	*	*	*	*	*	*	*
35.5	P <sub>GA</sub>	28.5	39.1	46.9	59.4	69.7	78.9	86.3	100	118	119	137	146	149	155	155	*	*	*	*	*	*	*	*
	P <sub>GB</sub>	63.3	92.1	110	142	168	199	219	296	356	381	443	525	555	674	705	813	849	813	810	*	*	*	*
	P <sub>GC</sub>	66.1	109	131	184	219	272	320	369	516	568	666	880	933	1091	1141	*	*	*	*	*	*	*	*
	P <sub>GD</sub>	94.6	155	187	258	306	384	445	544	738	814	949	1228	1299	1566	1636	*	*	*	*	*	*	*	*
40	P <sub>GA</sub>	25	34.2	44.9	52.4	67.2	74.7	83.6	97	115	116	136	146	153	160	164	175	*	*	*	*	*	*	*
	P <sub>GB</sub>	55.1	79.6	105	124	160	186	211	279	337	362	424	500	541	647	690	779	836	786	808	*	*	*	*
	P <sub>GC</sub>	55.7	91	123	152	205	246	300	339	480	526	623	816	891	1022	1092	*	*	*	*	*	*	*	*
	P <sub>GD</sub>	79.8	129	175	215	286	348	418	503	688	755	888	1144	1245	1472	1572	*	*	*	*	*	*	*	*
45	P <sub>GA</sub>	24.5	33.5	42.5	51.3	64.4	69.5	80.4	90.8	113	110	134	142	154	159	169	179	190	*	*	*	*	*	*
	P <sub>GB</sub>	53.9	77.7	98.4	120	151	170	199	257	326	333	409	465	517	607	665	737	801	746	785	*	*	*	*
	P <sub>GC</sub>	54.1	87.8	113	147	190	222	275	306	454	473	592	739	828	933	1029	*	*	*	*	*	*	*	*
	P <sub>GD</sub>	77.7	125	161	206	265	314	384	457	655	677	847	1037	1160	1346	1481	*	*	*	*	*	*	*	*
50	P <sub>GA</sub>	24.9	33.9	37.7	51.7	57.8	70.2	77.7	95.2	113	120	138	163	161	191	184	212	216	206	*	*	*	*	*
	P <sub>GB</sub>	54.4	77.1	85.7	118	132	167	188	256	310	340	392	483	491	640	639	739	780	837	783	*	*	*	*
	P <sub>GC</sub>	54.2	85.7	94.6	142	158	213	250	300	421	473	552	752	755	958	951	*	*	*	*	*	*	*	*
	P <sub>GD</sub>	77.5	122	135	200	223	303	352	445	606	684	794	1053	1064	1380	1376	*	*	*	*	*	*	*	*
56	P <sub>GA</sub>	23.1	31.6	37.2	48.7	57	66.1	73.2	89.4	108	116	133	161	179	193	211	229	240	236	234	*	*	*	*
	P <sub>GB</sub>	50	71.4	83.7	110	129	156	173	234	288	314	363	450	504	601	665	731	771	823	866	*	*	*	*
	P <sub>GC</sub>	48.9	77.4	91.4	129	152	192	227	267	379	426	494	680	766	871	969	*	*	*	*	*	*	*	*
	P <sub>GD</sub>	70.3	111	130	183	215	272	318	398	549	614	716	954	1076	1260	1401	*	*	*	*	*	*	*	*
63	P <sub>GA</sub>	22.3	30.4	37.1	47.3	56.6	64.2	72.5	87.3	108	114	137	158	168	192	202	231	242	244	240	*	*	*	*
	P <sub>GB</sub>	48.3	68.7	82.9	107	127	150	168	226	283	303	367	431	463	579	615	712	750	808	828	*	*	*	*
	P <sub>GC</sub>	46.3	73.1	89.2	123	147	181	217	252	368	401	494	639	685	824	877	*	*	*	*	*	*	*	*
	P <sub>GD</sub>	66.7	105	127	174	210	259	304	377	531	582	712	899	966	1198	1267	*	*	*	*	*	*	*	*
71	P <sub>GA</sub>	20.7	29.1	34.3	45.2	52.7	60.4	67.4	81.3	100	107	127	153	163	184	198	222	239	238	243	*	*	*	*
	P <sub>GB</sub>	44.8	65.3	76.3	102	118	141	156	210	257	285	334	409	444	546	590	671	726	763	808	*	*	*	*
	P <sub>GC</sub>	42	67.7	80.6	113	134	163	195	226	327	363	443	589	647	763	830	*	*	*	*	*	*	*	*
	P <sub>GD</sub>	60.8	97.9	115	162	190	236	275	340	474	528	638	834	912	1109	1204	*	*	*	*	*	*	*	*
80	P <sub>GA</sub>			32.9		51.1		65.3		96.9		123		158		190		231		237	*	*	*	*
	P <sub>GB</sub>			73.6		114		151		248		323		423		556		684		764	*	*	*	*
	P <sub>GC</sub>			76		127		184																

# Zahnradgetriebe

Nennleistungen  
Bauart B4..  
Größen 5 - 26

# Gear Units

Nominal Power Ratings  
Type B4..  
Sizes 5 - 26

# Réducteurs à engrenages

Puissances nominales  
Type B4..  
Tailles 5 - 26

Nennleistungen P <sub>2N</sub> (kW) / Nominal power ratings P <sub>2N</sub> (kW) / Puissances nominales P <sub>2N</sub> (kW)																								
i <sub>N</sub>	n <sub>1</sub>	n <sub>2</sub>	Getriebegrößen / Gear unit sizes / Tailles réducteurs																					
			5	6	7	8	9	10	11	12	13	14	15	16	17	18	19	20	21	22	23	24	25	26
80	1800	23	27		52		85		148		218		368		481		722*		1011*		1348*		1926*	
	1500	18.8	22		42		70		121		178		301		393		590		826		1102		1574	
	1200	15	18		34		56		96		142		240		314		471		659		879		1256	
	1000	12.5	15		28		46		80		118		200		261		392		549		732		1047	
90	1800	20	24		45		74		129		189		320	362	418	502	628*	722*	879*	984*	1172*	1340*	1675*	1884*
	1500	16.7	20		37		62		107		158		267	302	349	419	524	603	734	821	979	1119	1398	1573
	1200	13.3	16		30		49		85		126		213	240	278	334	417	480	584	654	779	891	1114	1253
	1000	11.1	13		25		41		71		105		177	201	232	278	348	400	488	546	650	743	929	1046
100	1800	18	21	29	40	51	67	83	116	147	170	212	288	326	376	452	565*	650*	791*	885*	1055*	1206*	1507*	1696*
	1500	15	18	24	34	42	56	69	96	122	142	177	240	271	314	376	471	541	659	738	879	1005	1256	1413
	1200	12	14	19	27	34	44	55	77	98	113	141	192	217	251	301	376	433	527	590	703	804	1005	1130
	1000	10	12	16	22	28	37	46	64	81	94	118	160	181	209	251	314	361	439	492	586	670	837	942
112	1800	16.1	19	26	36	45	60	74	103	131	152	190	257	291	337	404	505*	581*	708*	792*	944*	1078*	1348*	1517*
	1500	13.4	16	21	30	38	50	62	86	109	127	158	214	242	280	336	420	484	589	659	785	898	1122	1262
	1200	10.7	12	17	24	30	39	49	69	87	101	126	171	193	224	268	336	386	470	526	627	717	896	1008
	1000	8.9	10	14	20	25	33	41	57	72	84	105	142	161	186	223	279	321	391	438	521	596	745	838
125	1800	14.4	17	23	32	41	53	66	92	117	136	170	230	260	301	361	452*	520*	633*	708*	844*	965*	1206*	1357*
	1500	12	14	19	27	34	44	55	77	98	113	141	192	217	251	301	376	433	527	590	703	804	1005	1130
	1200	9.6	11	15	21	27	35	44	61	78	91	113	153	173	201	241	301	346	422	472	562	643	804	904
	1000	8	9.7	12	18	22	29	37	51	65	75	94	128	144	167	201	251	289	351	393	469	536	670	753
140	1800	12.9	15	20	29	36	48	59	83	105	122	152	206	233	270	324	405*	466*	567*	634*	756*	864*	1080*	1215*
	1500	10.7	12	17	24	30	39	49	69	87	101	126	171	193	224	268	336	386	470	526	627	717	896	1008
	1200	8.6	10	13	19	24	32	39	55	70	81	101	137	155	180	216	270	310	378	423	504	576	720	810
	1000	7.1	8.6	11	16	20	26	32	45	57	67	84	113	128	148	178	223	256	312	349	416	475	594	669
160	1800	11.3	13	18	25	32	42	52	72	92	107	133	181	204	236	283	354*	408*	496*	556*	662*	757*	946*	1064*
	1500	9.4	11	15	21	26	35	43	60	76	89	111	150	170	196	236	295	339	413	462	551	629	787	885
	1200	7.5	9.1	12	17	21	28	34	48	61	71	88	120	135	157	188	235	270	329	369	439	502	628	706
	1000	6.3	7.6	10	14	17	23	29	40	51	59	74	100	114	131	158	197	227	277	310	369	422	527	593
180	1800	10	12	16	22	28	37	46	64	81	94	118	160	181	209	251	314*	361*	439*	492*	586*	670*	837*	942*
	1500	8.3	10	13	18	23	31	38	53	67	78	98	132	150	173	208	260	299	365	408	486	556	695	782
	1200	6.7	8.1	10	15	19	25	31	43	54	63	79	107	121	140	168	210	242	294	329	392	449	561	631
	1000	5.6	6.8	9	12	15	20	25	36	45	53	66	89	101	117	140	175	202	246	275	328	375	469	527
200	1800	9	10	14	20	25	33	41	58	73	85	106	144	163	188	226	282*	325*	395*	442*	527*	603*	753*	848*
	1500	7.5	9.1	12	17	21	28	34	48	61	71	88	120	135	157	188	235	270	329	369	439	502	628	706
	1200	6	7.2	9.7	13	17	22	27	38	49	56	70	96	108	125	150	188	216	263	295	351	402	502	565
	1000	5	6	8.1	11	14	18	23	32	40	47	59	80	90	104	125	157	180	219	246	293	335	418	471
224	1800	8	9.7	12	18	22	29	37	51	65	75	94	128	144	167	201	251*	289*	351*	393*	469*	536*	670*	753*
	1500	6.7	8.1	10	15	19	25	31	43	54	63	79	107	121	140	168	210	242	294	329	392	449	561	631
	1200	5.4	6.5	8.7	12	15	20	24	34	44	51	63	86	97	113	135	169	195	237	265	316	361	452	508
	1000	4.5	5.4	7.3	10	12	16	20	29	36	42	53	72	81	94	113	141	162	197	221	263	301	376	424
250	1800	7.2	8.7	11	16	20	26	33	46	58	68	85	115	130	150	180	226*	260*	316*	354*	422*	482*	603*	678*
	1500	6	7.2	9.7	13	17	22	27	38	49	56	70	96	108	125	150	188	216	263	295	351	402	502	565
	1200	4.8	5.8	7.7	10	13	17	22	30	39	45	56	76	86	100	120	150	173	211	236	281	321	402	452
	1000	4	4.8	6.4	9	11	14	18	25	32	37	47	64	72	83	100	125	144	175	196	234	268	335	376
280	1800	6.4	7.7	10	14	18	23	29	41	52	60	75	102	115	134	160	201*	231*	281*	314*	375*	428*	536*	603*
	1500	5.4	6.5	8.7	12	15	19	24	34	44	51	63	86	97	113	135	169	195	237	265	316	361	452	508
	1200	4.3	5.2	6.9	9.7	12	15	19	27	35	40	50	68	77	90	108	135	155	189	211	252	288	360	405
	1000	3.6	4.3	5.8	8.1	10	13	16	23	29	34	42	57	65	75	90	113	130	158	177	211	241	301	339
315	1800	5.7	6.6	9.2	12	16	20	26	35	46	54	67	91	103	119	143	179*	205*	250*	280*	334*	381*	477*	537*
	1500	4.8	5.6	7.7	10	13	17	22	30	39	45	56	76	86	100	120	150	173	211	236	281	321	402	452
	1200	3.8	4.4	6.1	8.1	10	13	17	23	31	36	44	60	68	79	95	119	137	167	187	222	254	318	358
	1000	3.2	3.7	5.1	6.8	9.1	11	14	20	26	30	37	51	57	67	80	100	115	140	157	187	214	268	301
355	1800	5.1		8.2		14		23		41		60		92		128		184*		250*		341*		480*
	1500	4.2		6.8		11		19		34		49		76		105		151		206		281		395
	1200	3.4		5.5		9.4		15		27		40		61		85		122		167		227		320
	1000	2.8		4.5		7.7		12		22		33		50		70		101		137		187		263
400	1800	4.5		6.8		12		20		35		53												
	1500	3.8		5.7		10		17		29		44												
	1200	3		4.5		8		13		23		35												
	1000	2.5		3.7		6.6		11		19		29												

Druckschmierung bei Horizontalgetrieben erforderlich    
  Forced lubrication required on horizontal gear units    
  La lubrification sous pression est nécessaire en position horizontale pour ces réducteurs  
 \* Getriebe nur auf Anfrage    
  \* Gear units only on request    
  \* Réducteur à engrenages seulement sur demande

### Zahnradgetriebe

Nenn-Abtriebsdrehmomente  
 Bauart B4..  
 Größen 5 - 26

### Gear Units

Nominal Output Torques  
 Type B4..  
 Sizes 5 - 26

### Réducteurs à engrenages

Couples nominaux de sortie  
 Type B4..  
 Tailles 5 - 26

Nenn-Abtriebsdrehmomente $T_{2N}$ (kNm) Nominal output torques $T_{2N}$ (kNm) / Couples nominaux de sortie $T_{2N}$ (kNm)																							
$i_N$	Getriebegrößen / Gear unit sizes / Tailles réducteurs																						
	4	5	6	7	8	9	10	11	12	13	14	15	16	17	18	19	20	21	22	23	24	25	26
5	6.1	9.4		19		29.9		46.0		68.6		122											
5.6	6.2	9.4		19		29.9		48.1		69.6		122	135	195									
6.3	6.2	9.4	12	19	23.8	29.9	38	50.2	58.8	73.8	85.2	130	141	195									
7.1	6.2	9.4	12	19	23.8	29.9	38	50.2	60.0	75.9	87.3	132	145	195	230								
8	6.2	9.4	12	19	23.8	29.9	38	50.2	63.1	80	91.5	132	148	195	230								
9	6.2	9.4	12	19	23.8	29.9	38	50.2	63.1	81.1	94.6	132	148	195	230								
10	6.2	9.4	12	19	23.8	29.9	38	54	66.3	81.1	98.8	132	148	195	230								
11.2	6.2	9.4	12	19	23.8	29.9	38	54	66.3	81.1	101	132	148	195	230								
12.5	5.5	9.4	12	17	23.8	28	38	52.4	66.3	79.5	101	132	148	195	230	250		340					
14	6	9.8	12	18.2	23.8	29.5	38	56.7	66.3	81.6	101	137	148	195	230	262	295	360	405				
16	6.6	10.5	12	19.8	21.5	31	35.6	59.9	66.3	83.8	99.4	142	154	200	230	275	308	380	422				
18	6.7	11.3	12.6	21.1	23.1	33.9	37.5	62	69.5	86.7	102	148	160	200	240	288	320	400	438				
20	6.7	11.6	13.2	21.7	25	35.7	39.3	63.5	72.7	90.7	105	153	167	200	240	300	332	420	455	560		800	
22.4	6.7	11.6	14.2	21.7	26.5	35.7	41.8	63.5	75.6	90.7	108	153	173	200	240	300	345	420	470	560	640	800	900
25	6.7	11.6	15.5	21.7	27.2	35.7	43.8	63.5	77.2	90.7	113	153	173	200	240	300	345	420	470	560	640	800	900
28	6.7	11.6	15.5	21.7	27.2	35.7	43.8	63.5	77.2	90.7	113	153	173	200	240	300	345	420	470	560	640	800	900
31.5	6.7	11.6	15.5	21.7	27.2	35.7	43.8	63.5	77.2	90.7	113	153	173	200	240	300	345	420	470	560	640	800	900
35.5	6.7	11.6	15.5	21.7	27.2	35.7	43.8	63.5	77.2	90.7	113	153	173	200	240	300	345	420	470	560	640	800	900
40	6.7	11.6	15.5	21.7	27.2	35.7	43.8	63.5	77.2	90.7	113	153	173	200	240	300	345	420	470	560	640	800	900
45	6.7	11.6	15.5	21.7	27.2	35.7	43.8	63.5	77.2	90.7	113	153	173	200	240	300	345	420	470	560	640	800	900
50	6.7	11.6	15.5	21.7	27.2	35.7	43.8	63.5	77.2	90.7	113	153	173	200	240	300	345	420	470	560	640	800	900
56	6.7	11.6	15.5	21.7	27.2	35.7	43.8	63.5	77.2	90.7	113	153	173	200	240	300	345	420	470	560	640	800	900
63	6.6	11.4	15.5	21.4	27.2	35.7	43.8	63.5	77.2	90.7	113	153	173	200	240	300	345	420	470	560	640	800	900
71	6.6	11	15.5	20	27.2	34	43.8	60	77.2	90.7	113	153	173	200	240	300	345	420	470	560	640	800	900
80		11.6	14	21.7	26.9	35.7	43.8	61.6	77.2	90.7	113	153	173	200	240	300	345	420	470	560	640	800	900
90		11.6	14	21.7	25.2	35.7	43	61.6	75	90.7	113	153	173	200	240	300	345	420	470	560	640	800	900
100		11.6	15.5	21.7	27.2	35.7	44.2	61.6	78	90.7	113	153	173	200	240	300	345	420	470	560	640	800	900
112		11.6	15.5	21.7	27.2	35.7	44.2	61.6	78	90.7	113	153	173	200	240	300	345	420	470	560	640	800	900
125		11.6	15.5	21.7	27.2	35.7	44.2	61.6	78	90.7	113	153	173	200	240	300	345	420	470	560	640	800	900
140		11.6	15.5	21.7	27.2	35.7	44.2	61.6	78	90.7	113	153	173	200	240	300	345	420	470	560	640	800	900
160		11.6	15.5	21.7	27.2	35.7	44.2	61.6	78	90.7	113	153	173	200	240	300	345	420	470	560	640	800	900
180		11.6	15.5	21.7	27.2	35.7	44.2	61.6	78	90.7	113	153	173	200	240	300	345	420	470	560	640	800	900
200		11.6	15.5	21.7	27.2	35.7	44.2	61.6	78	90.7	113	153	173	200	240	300	345	420	470	560	640	800	900
224		11.6	15.5	21.7	27.2	35.7	44.2	61.6	78	90.7	113	153	173	200	240	300	345	420	470	560	640	800	900
250		11.6	15.5	21.7	27.2	35.7	44.2	61.6	78	90.7	113	153	173	200	240	300	345	420	470	560	640	800	900
280		11.6	15.5	21.7	27.2	35.3	44.2	61.6	78	90.7	113	153	173	200	240	300	345	420	470	560	640	800	900
315		11.2	15.5	20.5	27.2	34	44.2	60	78	90.7	113	153	173	200	240	300	345	420	470	560	640	800	900
355			15.5		26.5		44.2		78		113		173		240		345		470		640		900
400			14.5		25.5		43		75		113												

**B2**

siehe Seiten 38 - 43  
 see pages 38 - 43  
 voir pages 38 - 43

**B3**

siehe Seiten 44 - 49  
 see pages 44 - 49  
 voir pages 44 - 49

## Zahnradgetriebe

Wärmegrenzleistungen

Bauart B4..

Größen 5 - 26

$n_1 = 1000 \text{ min}^{-1}$

## Gear Units

Thermal Capacities

Type B4..

Sizes 5 - 26

$n_1 = 1000 \text{ min}^{-1}$

## Réducteurs à engrenages

Capacités thermiques

Type B4..

Tailles 5 - 26

$n_1 = 1000 \text{ min}^{-1}$

Wärmegrenzleistungen $P_G$ (kW) / Thermal capacities $P_G$ (kW) / Capacités thermiques $P_G$ (kW)																							
$i_N$		Getriebegrößen / Gear unit sizes / Tailles réducteurs																					
		5	6	7	8	9	10	11	12	13	14	15	16	17	18	19	20	21	22	23	24	25	26
80	$P_{GA}$	28.6		42.4		60		90.6		121		162		183		250		351		*		*	
90	$P_{GA}$	27.9		41		58.6		87.9		118		155	167	175	188	240	256	339	355	*	*	*	*
100	$P_{GA}$	26.6	30.6	38.8	45.3	55.6	60.4	84.4	101	112	130	146	160	164	180	227	246	319	344	*	*	*	*
112	$P_{GA}$	25.6	29.9	37.4	44	53.5	59	80.4	97.6	107	126	139	151	157	169	216	232	309	322	*	*	*	*
125	$P_{GA}$	24.5	28.6	35.7	41.6	51	56	77	93.2	102	119	132	144	149	161	205	221	291	313	*	*	*	*
140	$P_{GA}$	23.4	27.5	33.9	40.1	48.1	53.9	72.8	88.8	97.6	114	128	137	144	154	198	211	281	294	*	*	*	*
160	$P_{GA}$	21.5	26.3	30.9	38.2	44	51.3	66.4	85.1	92.4	110	121	132	136	148	187	203	265	284	*	*	*	*
180	$P_{GA}$	21.1	25.1	30.1	36.4	42.9	48.7	64.6	80.6	87.2	103	114	124	128	139	175	191	248	269	*	*	*	*
200	$P_{GA}$	20.4	23.1	29.9	33.2	42	44.6	63.2	73.6	85.2	98.5	112	117	126	132	174	179	240	251	*	*	*	*
224	$P_{GA}$	19	22.7	27.8	32.4	39.3	43.4	59.4	71.8	79.9	93.2	105	116	117	130	163	179	224	243	*	*	*	*
250	$P_{GA}$	18.5	21.8	26.9	32.1	37.9	42.5	57.5	70.1	77.3	90.6	102	108	114	122	158	168	217	227	*	*	*	*
280	$P_{GA}$	17.6	20.4	25.2	30	36.1	39.8	55	65.8	73	85.2	95	104	107	117	148	161	207	220	*	*	*	*
315	$P_{GA}$	16.5	19.8	23.6	28.8	33.9	38.4	51.3	63.7	69.6	82.4	89.7	98.5	101	110	140	153	193	210	*	*	*	*
355	$P_{GA}$		19		27.1		36.6		60.8		77.8		92.4		104		144		196		*		*
400	$P_{GA}$		17.7		25.4		34.5		56.7		74.1												

$n_1 = 1200 \text{ min}^{-1}$

$n_1 = 1200 \text{ min}^{-1}$

$n_1 = 1200 \text{ min}^{-1}$

Wärmegrenzleistungen $P_G$ (kW) / Thermal capacities $P_G$ (kW) / Capacités thermiques $P_G$ (kW)																							
$i_N$		Getriebegrößen / Gear unit sizes / Tailles réducteurs																					
		5	6	7	8	9	10	11	12	13	14	15	16	17	18	19	20	21	22	23	24	25	26
80	$P_{GA}$	30.5		45.1		63.5		94.9		125		165		183		248		334		*		*	
90	$P_{GA}$	29.9		43.7		62.2		92.3		123		159	170	176	189	240	255	327	336	*	*	*	*
100	$P_{GA}$	28.5	32.7	41.4	48.2	59.1	64.1	88.9	106	117	135	150	163	167	182	228	247	311	330	*	*	*	*
112	$P_{GA}$	27.5	32	39.9	46.9	56.9	62.7	84.9	102	112	132	144	155	161	173	219	235	306	314	*	*	*	*
125	$P_{GA}$	26.3	30.6	38.2	44.4	54.4	59.7	81.5	98.4	108	125	138	149	154	166	210	226	291	309	*	*	*	*
140	$P_{GA}$	25.1	29.5	36.3	42.9	51.4	57.5	77.3	94.1	103	120	134	143	149	159	204	217	284	294	*	*	*	*
160	$P_{GA}$	23.1	28.2	33.2	41	47	54.9	70.7	90.4	97.8	116	127	138	142	155	194	210	271	288	*	*	*	*
180	$P_{GA}$	22.7	27	32.4	39	46	52.2	69	85.9	92.8	110	120	131	135	146	183	200	256	276	*	*	*	*
200	$P_{GA}$	21.9	24.9	32.1	35.7	45.1	47.8	67.7	78.7	91	105	119	125	134	140	183	189	251	261	*	*	*	*
224	$P_{GA}$	20.4	24.4	30	34.9	42.3	46.7	63.8	77	85.6	99.8	112	123	125	138	174	190	237	256	*	*	*	*
250	$P_{GA}$	20	23.5	29	34.6	40.8	45.8	61.9	75.4	83.1	97.4	109	116	122	131	169	180	232	243	*	*	*	*
280	$P_{GA}$	19	22	27.2	32.3	39	43	59.3	71	78.8	92	102	113	115	127	160	174	224	237	*	*	*	*
315	$P_{GA}$	17.8	21.4	25.5	31.1	36.6	41.5	55.4	68.7	75.2	89	96.9	106	109	119	152	165	209	227	*	*	*	*
355	$P_{GA}$		20.5		29.2		39.6		65.6		84		99.7		113		155		211		*		*
400	$P_{GA}$		19.1		27.4		37.3		61.2		80												

\* Auf Anfrage

$P_{GA}$  (kW) Getriebe ohne Zusatzkühlung \*\*)

\*\*\*) Werte gelten für:  
Einschaltdauer: 100 %  
Aufstellung in großer Halle  
Höhenlage bis 1000 m

\* On request

$P_{GA}$  (kW) Gear units without auxiliary cooling \*\*)

\*\*\*) Values refer to:  
Operating cycle: 100 %  
Installation in a large hall  
Altitude up to 1000 m

\* Sur demande

$P_{GA}$  (kW) Réducteurs sans refroidissement supplémentaire \*\*)

\*\*\*) Les valeurs sont valables pour:  
Durée d'utilisation: 100 %  
Implantation dans un grand hall  
Altitude jusqu'à 1000 m



## Zahnradgetriebe

Wärmegrenzleistungen

Bauart B4..

Größen 5 - 26

$n_1 = 1500 \text{ min}^{-1}$

## Gear Units

Thermal Capacities

Type B4..

Sizes 5 - 26

$n_1 = 1500 \text{ min}^{-1}$

## Réducteurs à engrenages

Capacités thermiques

Type B4..

Tailles 5 - 26

$n_1 = 1500 \text{ min}^{-1}$

Wärmegrenzleistungen $P_G$ (kW) / Thermal capacities $P_G$ (kW) / Capacités thermiques $P_G$ (kW)																							
$i_N$		Getriebegrößen / Gear unit sizes / Tailles réducteurs																					
		5	6	7	8	9	10	11	12	13	14	15	16	17	18	19	20	21	22	23	24	25	26
80	$P_{GA}$	31.7		46.9		66.1		98.6		130		171		189		256		343		*		*	
90	$P_{GA}$	31.1		45.5		64.7		95.9		128		164	175	183	195	248	264	337	345	*	*	*	*
100	$P_{GA}$	29.6	34	43.1	50.2	61.5	66.7	92.4	110	121	140	156	169	173	188	236	255	321	339	*	*	*	*
112	$P_{GA}$	28.6	33.3	41.5	48.8	59.2	65.3	88.3	106	116	137	149	161	167	179	227	243	315	323	*	*	*	*
125	$P_{GA}$	27.4	31.8	39.7	46.2	56.6	62.1	84.8	102	112	130	143	155	159	172	218	234	300	318	*	*	*	*
140	$P_{GA}$	26.1	30.7	37.8	44.6	53.5	59.9	80.4	97.8	107	125	139	148	155	165	211	225	294	304	*	*	*	*
160	$P_{GA}$	24.1	29.4	34.5	42.7	49	57.2	73.6	94.1	101	121	132	143	147	160	202	218	281	298	*	*	*	*
180	$P_{GA}$	23.6	28.1	33.7	40.7	47.9	54.3	71.8	89.3	96.5	114	125	136	140	152	190	208	266	286	*	*	*	*
200	$P_{GA}$	22.8	25.9	33.5	37.2	47	49.8	70.5	81.9	94.7	109	124	130	139	146	191	196	260	271	*	*	*	*
224	$P_{GA}$	21.3	25.4	31.2	36.4	44	48.6	66.5	80.2	89.1	104	117	128	130	144	181	198	246	266	*	*	*	*
250	$P_{GA}$	20.8	24.5	30.2	36	42.5	47.8	64.5	78.6	86.6	101	114	120	127	136	176	187	241	252	*	*	*	*
280	$P_{GA}$	19.8	22.9	28.4	33.7	40.6	44.8	61.8	74	82.1	95.9	106	117	120	132	167	182	233	247	*	*	*	*
315	$P_{GA}$	18.6	22.3	26.6	32.4	38.2	43.2	57.8	71.6	78.4	92.7	100	110	113	124	158	172	217	236	*	*	*	*
355	$P_{GA}$		21.3		30.4		41.2		68.4		87.6		103		117		162		220		*		*
400	$P_{GA}$		19.9		28.6		38.9		63.8		83.4												

$n_1 = 1800 \text{ min}^{-1}$

$n_1 = 1800 \text{ min}^{-1}$

$n_1 = 1800 \text{ min}^{-1}$

Wärmegrenzleistungen $P_G$ (kW) / Thermal capacities $P_G$ (kW) / Capacités thermiques $P_G$ (kW)																							
$i_N$		Getriebegrößen / Gear unit sizes / Tailles réducteurs																					
		5	6	7	8	9	10	11	12	13	14	15	16	17	18	19	20	21	22	23	24	25	26
80	$P_{GA}$	33		48.6		68.1		100		130		168		184		245		312		*		*	
90	$P_{GA}$	32.3		47.2		66.8		97.9		129		163	173	178	190	239	253	311	311	*	*	*	*
100	$P_{GA}$	30.9	35.4	44.8	52	63.6	68.8	94.7	112	123	142	155	168	170	185	230	247	301	312	*	*	*	*
112	$P_{GA}$	29.8	34.7	43.2	50.6	61.4	67.5	90.7	109	118	139	150	161	165	177	223	238	300	302	*	*	*	*
125	$P_{GA}$	28.5	33.2	41.4	48	58.8	64.3	87.3	105	114	133	144	155	160	171	216	231	290	303	*	*	*	*
140	$P_{GA}$	27.3	32	39.4	46.5	55.6	62.2	83.1	100	109	128	141	150	156	166	212	224	288	294	*	*	*	*
160	$P_{GA}$	25.2	30.7	36.1	44.5	51	59.5	76.2	97.2	104	124	135	146	150	162	204	220	278	292	*	*	*	*
180	$P_{GA}$	24.7	29.4	35.2	42.5	50	56.6	74.6	92.6	99.8	118	129	140	143	155	194	211	266	285	*	*	*	*
200	$P_{GA}$	23.9	27.1	35	38.9	49.1	52	73.4	85.2	98.3	113	128	134	143	150	196	201	264	274	*	*	*	*
224	$P_{GA}$	22.3	26.7	32.7	38.1	46.1	50.9	69.5	83.7	92.9	108	121	133	135	149	187	205	253	273	*	*	*	*
250	$P_{GA}$	21.8	25.7	31.7	37.8	44.6	50.1	67.6	82.3	90.6	106	119	126	133	142	184	195	251	262	*	*	*	*
280	$P_{GA}$	20.9	24.1	29.8	35.4	42.7	47.1	65	77.7	86.3	100	112	123	126	139	175	191	245	260	*	*	*	*
315	$P_{GA}$	19.5	23.5	27.9	34.1	40.1	45.4	60.7	75.2	82.3	97.4	106	116	119	131	166	180	228	248	*	*	*	*
355	$P_{GA}$		22.4		32		43.3		71.8		92		109		123		170		231		*		*
400	$P_{GA}$		21		30		40.8		67		87.6												

\* Auf Anfrage

$P_{GA}$  (kW) Getriebe ohne Zusatzkühlung \*\*)

\*\*\*) Werte gelten für:  
Einschaltdauer: 100 %  
Aufstellung in großer Halle  
Höhenlage bis 1000 m

\* On request

$P_{GA}$  (kW) Gear units without auxiliary cooling \*\*)

\*\*\*) Values refer to:  
Operating cycle: 100 %  
Installation in a large hall  
Altitude up to 1000 m

\* Sur demande

$P_{GA}$  (kW) Réducteurs sans refroidissement supplémentaire \*\*)

\*\*\*) Les valeurs sont valables pour:  
Durée d'utilisation: 100 %  
Implantation dans un grand hall  
Altitude jusqu'à 1000 m

# Zahnradgetriebe

# Gear Units

# Réducteurs à engrenages

Ist-Übersetzungen  
 Bauarten H1..., H2..., H3..., H4..  
 Größen 3 - 14

Actual Ratios  
 Types H1..., H2..., H3..., H4..  
 Sizes 3 - 14

Rapports réels  
 Types H1..., H2..., H3..., H4..  
 Tailles 3 - 14

Ist-Übersetzungen i / Actual ratios i / Rapports réels i												
i <sub>N</sub>	Getriebegrößen / Gear unit sizes / Tailles réducteurs											
	3	4	5	6	7	8	9	10	11	12	13	14
1.25	1.243	-	1.256	-	1.263	-	1.270	-	-	-	-	-
1.4	1.371	-	1.378	-	1.389	-	1.400	-	-	-	-	-
1.6	1.594	-	1.588	-	1.606	-	1.625	-	1.636	-	1.588	-
1.8	1.829	-	1.839	-	1.774	-	1.800	-	1.806	-	1.839	-
2.0	2.000	-	2.034	-	1.966	-	2.000	-	2.000	-	2.034	-
2.24	2.194	-	2.259	-	2.308	-	2.231	-	2.222	-	2.259	-
2.5	2.536	-	2.520	-	2.583	-	2.500	-	2.480	-	2.520	-
2.8	2.808	-	2.826	-	2.800	-	2.741	-	2.783	-	2.826	-
3.15	3.125	-	3.190	-	3.130	-	3.208	-	3.080	-	3.208	-
3.55	3.500	-	3.591	-	3.524	-	3.591	-	3.478	-	3.591	-
4.0	3.950	-	4.050	-	4.000	-	4.050	-	3.905	-	4.050	-
4.5	4.435	-	4.619	-	4.400	-	4.381	-	4.421	-	4.619	-
5.0	4.952	-	4.900	-	4.905	-	4.947	-	5.150	-	4.900	-
5.6	5.579	-	5.556	-	5.526	-	5.684	-	5.474	-	5.556	-
6.3	-	6.319	6.286	-	6.088	-	6.260	-	6.246	-	6.410	-
7.1	-	6.857	7.213	-	7.048	-	7.247	-	6.900	-	7.100	-
8.0	-	7.778	7.889	7.792	7.799	7.676	8.018	7.848	7.644	7.941	7.889	7.944
9.0	-	8.485	8.652	8.940	8.660	8.887	8.904	9.085	8.974	8.772	8.799	8.800
10	-	9.722	10.002	9.778	9.660	9.833	9.932	10.053	10.046	9.718	9.861	9.778
11.2	-	10.694	11.075	10.724	10.648	10.920	11.138	11.163	10.889	11.410	10.811	10.906
12.5	-	12.444	12.326	12.397	11.807	12.180	12.574	12.452	12.174	12.773	12.655	12.222
14	-	13.865	13.806	13.726	13.939	13.426	14.152	13.964	13.704	13.844	14.164	13.399
16	-	15.556	15.581	15.278	15.717	14.887	15.962	15.765	15.556	15.478	15.975	15.685
18	-	17.602	17.493	17.111	17.598	17.576	18.204	17.743	17.111	17.423	17.280	17.556
20	-	19.444	19.534	19.311	19.742	19.817	19.312	20.012	19.074	19.778	19.515	19.800
22.4	-	22.037	22.006	21.681	20.982	22.189	21.895	22.824	21.491	21.756	22.020	21.418
25	-	-	25.011	24.212	25.540	24.892	25.439	24.212	24.706	24.251	25.372	24.187
28	-	-	28.490	27.275	27.711	26.456	29.187	27.451	28.602	27.325	29.373	27.292
31.5	-	-	31.161	30.999	31.433	32.202	31.924	31.894	31.648	31.412	32.501	31.447
35.5	-	-	34.177	35.312	34.291	34.940	35.013	36.593	35.144	36.366	36.092	36.406
40	-	-	39.508	38.622	39.292	39.633	40.474	40.024	39.200	40.238	40.257	40.283
45	-	-	43.745	42.360	43.221	43.236	44.816	43.897	43.210	44.683	45.147	44.733
50	-	-	48.689	48.967	50.293	49.542	49.881	50.744	47.911	49.840	50.968	49.896
56	-	-	54.532	54.220	56.033	54.496	55.866	56.187	56.566	54.938	57.365	55.957
63	-	-	61.543	60.347	62.867	63.413	63.049	62.537	63.778	60.916	64.699	63.171
71	-	-	69.742	67.589	71.139	70.651	70.787	70.041	71.414	71.919	73.789	71.100
80	-	-	78.723	76.279	78.583	79.267	79.049	79.046	80.111	81.089	78.278	80.190
90	-	-	86.806	86.440	89.061	89.696	89.050	88.748	85.146	90.798	88.750	91.457
100	-	-	-	97.572	101.554	99.083	101.210	99.106	103.639	101.856	103.114	97.020
112	-	-	-	107.590	115.256	112.294	115.290	111.645	112.450	108.257	118.306	110.000
125	-	-	-	-	125.733	128.046	126.098	126.890	127.556	131.769	129.398	127.803
140	-	-	-	-	143.985	145.322	138.301	144.542	139.152	142.973	141.920	146.633
160	-	-	-	-	158.251	158.533	159.874	158.093	159.444	162.178	164.058	160.380
180	-	-	-	-	174.630	181.546	177.022	173.392	175.389	176.921	181.654	175.901
200	-	-	-	-	193.629	199.533	197.028	200.439	204.089	202.722	202.184	203.339
224	-	-	-	-	228.606	220.185	220.671	221.938	227.382	222.994	226.446	225.149
250	-	-	-	-	257.753	244.141	249.043	247.020	255.111	259.484	255.560	250.594
280	-	-	-	-	288.615	288.242	282.219	276.663	288.678	289.100	286.925	280.665
315	-	-	-	-	305.352	324.993	318.563	312.234	318.889	324.356	320.413	316.751
355	-	-	-	-	344.112	363.906	351.273	353.827	361.407	367.034	360.951	355.625
400	-	-	-	-	-	385.010	-	399.393	-	405.444	-	397.131
450	-	-	-	-	-	433.881	-	440.402	-	459.504	-	447.376

# Zahnradgetriebe

# Gear Units

# Réducteurs à engrenages

Ist-Übersetzungen  
 Bauarten H1..., H2..., H3..., H4..  
 Größen 15 - 26

Actual Ratios  
 Types H1..., H2..., H3..., H4..  
 Sizes 15 - 26

Rapports réels  
 Types H1..., H2..., H3..., H4..  
 Tailles 15 - 26

Ist-Übersetzungen i / Actual ratios i / Rapports réels i												
Getriebegrößen / Gear unit sizes / Tailles réducteurs												i <sub>N</sub>
15	16	17	18	19	20	21	22	23	24	25	26	
-	-	-	-	-	-	-	-	-	-	-	-	1.25
-	-	-	-	-	-	-	-	-	-	-	-	1.4
-	-	-	-	-	-	-	-	-	-	-	-	1.6
-	-	-	-	-	-	-	-	-	-	-	-	1.8
2.000	-	2.000	-	1.967	-	-	-	-	-	-	-	2.0
2.231	-	2.250	-	2.296	-	-	-	-	-	-	-	2.24
2.481	-	2.481	-	2.560	-	-	-	-	-	-	-	2.5
2.760	-	2.760	-	2.870	-	-	-	-	-	-	-	2.8
3.087	-	3.087	-	3.238	-	-	-	-	-	-	-	3.15
3.476	-	3.476	-	3.450	-	-	-	-	-	-	-	3.55
3.947	-	3.947	-	3.944	-	-	-	-	-	-	-	4.0
4.579	-	4.526	-	4.400	-	-	-	-	-	-	-	4.5
5.100	-	4.900	-	4.950	-	-	-	-	-	-	-	5.0
5.778	-	5.556	-	5.700	-	-	-	-	-	-	-	5.6
6.449	-	6.154	-	6.410	-	6.500	-	6.306	-	6.280	-	6.3
7.120	7.316	7.125	7.147	7.100	7.312	7.200	7.265	7.038	7.059	6.915	7.232	7.1
7.882	8.076	7.884	8.274	7.889	8.100	8.000	8.047	7.882	7.878	7.635	7.963	8.0
8.758	8.941	8.755	9.155	8.799	9.000	8.923	8.941	8.868	8.824	8.915	8.792	9.0
9.774	9.935	9.765	10.167	9.788	10.038	9.926	9.973	9.780	9.926	9.939	10.266	10
10.967	11.087	10.951	11.340	10.887	11.167	11.040	11.094	10.878	10.948	11.141	11.445	11.2
12.139	12.440	12.432	12.717	12.176	12.420	12.348	12.339	12.166	12.176	12.571	12.829	12.5
13.708	13.769	13.915	14.438	13.712	13.891	13.905	13.801	13.700	13.619	13.394	14.476	14
15.389	15.550	15.694	16.159	15.570	15.643	15.789	15.541	15.557	15.336	15.314	15.424	16
17.424	17.457	17.899	18.225	18.061	17.763	18.316	17.647	17.839	17.415	17.082	17.634	18
20.297	19.765	18.988	20.786	20.117	20.605	20.400	20.471	19.312	19.969	19.218	19.671	20
21.374	23.024	20.930	22.050	21.782	22.950	22.368	22.800	22.039	21.618	21.108	22.129	22.4
24.716	24.245	24.202	24.306	25.283	24.850	25.837	25.000	25.457	24.671	24.322	24.306	25
27.304	28.036	26.736	28.106	28.006	28.844	28.523	28.877	28.103	28.497	28.157	28.007	28
30.248	30.971	29.619	31.048	31.117	31.950	31.579	31.879	31.115	31.459	31.156	32.424	31.5
35.514	34.311	34.776	34.397	34.708	35.500	35.088	35.294	34.572	34.830	34.598	35.876	35.5
39.756	40.284	38.929	40.385	38.897	39.596	39.158	39.216	38.582	38.700	38.591	39.840	40
43.090	45.096	42.194	45.208	42.642	44.375	43.936	43.765	43.290	43.189	43.278	44.438	45
48.175	48.878	47.174	49.000	49.917	48.648	48.632	49.105	47.916	48.459	49.132	49.835	50
54.229	54.647	53.102	54.783	55.870	56.948	54.920	54.353	54.112	53.638	54.990	56.576	56
61.557	61.514	60.278	61.667	63.013	63.739	61.654	61.381	60.747	60.573	62.021	63.322	63
67.713	69.826	66.306	70.000	68.162	71.888	69.806	68.908	68.780	68.001	70.735	71.418	71
75.481	76.809	73.912	77.000	76.974	77.762	81.316	78.019	80.120	76.992	75.037	81.452	80
85.046	85.620	83.279	85.833	88.439	87.816	86.427	90.882	85.156	89.687	85.076	86.407	90
97.768	96.471	95.735	96.711	100.079	100.895	99.020	96.594	97.564	95.323	100.783	97.967	100
113.186	110.901	110.833	111.176	115.862	114.174	109.386	110.670	107.778	109.214	111.637	116.054	112
125.238	128.390	122.634	128.710	128.198	132.180	121.182	122.255	119.400	120.647	124.041	128.552	125
139.074	142.060	136.183	142.414	142.362	146.254	142.279	135.439	140.186	133.657	138.354	142.835	140
155.125	157.756	151.900	158.148	158.792	162.413	159.273	159.017	156.931	156.925	155.051	159.316	160
170.993	175.962	167.438	176.400	178.079	181.156	172.632	178.011	170.093	175.669	169.982	178.544	180
189.597	193.962	185.656	194.444	201.040	203.160	193.004	192.941	190.166	190.402	198.983	195.737	200
223.845	215.065	219.192	215.600	226.272	229.355	217.257	215.711	214.062	212.872	222.710	229.132	224
252.385	253.914	247.139	254.545	255.201	258.141	246.617	242.817	242.990	239.622	251.183	256.454	250
282.605	286.288	276.730	287.000	291.058	291.144	271.278	275.630	267.289	272.004	271.709	289.241	280
317.021	320.566	310.431	321.364	308.761	332.052	302.399	303.193	297.952	299.204	306.839	312.877	315
336.946	359.606	329.942	360.500	350.069	352.249	340.720	337.975	335.710	333.528	352.538	353.329	355
-	382.207	-	383.158	-	399.375	-	380.805	-	375.794	-	405.953	400
-	-	-	-	-	-	-	-	-	-	-	-	450

# Zahnradgetriebe

# Gear Units

# Réducteurs à engrenages

Ist-Übersetzungen  
 Bauarten B2..., B3..., B4..  
 Größen 4 - 14

Actual Ratios  
 Types B2..., B3..., B4..  
 Sizes 4 - 14

Rapports réels  
 Types B2..., B3..., B4..  
 Tailles 4 - 14

Ist-Übersetzungen i / Actual ratios i / Rapports réels i											
i <sub>N</sub>	Getriebegrößen / Gear unit sizes / Tailles réducteurs										
	4	5	6	7	8	9	10	11	12	13	14
5.0	4.936	5.006	–	4.865	–	5.002	–	4.897	–	4.967	–
5.6	5.480	5.488	–	5.333	–	5.483	–	5.534	–	5.613	–
6.3	6.296	6.386	6.205	6.206	6.135	6.381	6.271	6.296	6.226	6.386	6.156
7.1	6.959	7.058	6.802	6.860	6.725	7.053	6.875	7.037	7.036	7.138	6.957
8.0	7.549	7.657	7.915	7.880	7.825	8.101	8.000	7.994	8.005	8.108	7.915
9.0	8.693	8.817	8.749	8.569	8.649	8.810	8.842	8.693	8.947	8.817	8.847
10	9.872	10.108	9.490	9.823	9.935	10.099	10.157	9.965	10.164	10.108	10.049
11.2	10.769	10.923	10.928	10.615	10.804	10.914	11.045	10.769	11.052	10.923	10.928
12.5	12.034	12.703	12.528	12.433	12.385	12.554	12.662	12.334	12.670	12.482	12.528
14	13.484	13.964	13.538	13.515	13.385	14.137	13.683	13.821	13.692	13.721	13.538
16	15.601	15.835	15.826	16.275	15.773	15.952	15.693	15.522	15.888	16.354	15.552
18	17.482	17.407	17.307	17.692	17.041	17.963	17.724	17.393	17.572	17.978	17.007
20	19.614	19.645	19.729	19.948	20.648	20.259	19.940	19.744	19.995	20.276	20.376
22.4	21.919	21.954	21.575	22.146	22.308	22.208	22.520	21.643	22.114	22.226	22.282
25	25.380	25.421	24.349	25.446	25.152	25.843	25.400	25.185	25.103	25.864	25.131
28	27.836	27.881	27.211	28.125	27.923	28.563	27.842	27.836	27.517	28.587	27.548
31.5	30.196	30.245	31.508	30.509	32.084	30.985	32.400	31.975	32.021	32.838	32.057
35.5	34.771	34.827	34.557	35.131	35.461	35.679	35.811	34.771	35.392	35.709	35.432
40	39.487	39.551	37.486	39.896	38.468	40.902	38.846	39.861	40.654	40.936	40.700
45	43.077	43.146	43.166	43.523	44.296	44.202	44.732	43.077	44.209	44.238	44.259
50	49.060	49.139	49.021	49.568	50.304	50.341	51.280	49.060	50.681	50.383	50.737
56	55.152	55.240	53.477	55.723	54.877	56.592	55.417	55.152	54.769	56.639	54.831
63	60.808	60.906	60.904	61.438	62.499	62.396	63.114	60.808	62.376	62.448	62.446
71	69.293	69.404	68.467	70.011	70.259	71.102	70.951	69.293	70.121	71.161	70.200
80	–	77.598	75.489	79.267	77.465	79.497	78.228	80.949	77.313	82.118	77.400
90	–	86.720	86.022	88.585	88.274	88.842	89.143	89.869	88.101	90.016	88.200
100	–	100.413	96.178	102.572	99.945	102.869	99.667	103.259	102.921	104.750	101.780
112	–	110.130	107.484	112.498	111.694	112.824	111.384	114.129	114.262	115.777	111.569
125	–	119.466	124.455	122.035	129.330	122.389	128.971	123.804	131.287	125.592	129.831
140	–	137.567	136.499	140.525	141.846	140.933	141.452	142.562	145.106	144.621	143.498
160	–	156.225	148.071	159.585	153.871	160.047	153.443	161.897	157.408	165.791	155.663
180	–	170.427	170.506	174.092	177.184	174.597	176.692	176.615	181.258	179.166	179.248
200	–	194.098	193.631	198.272	201.215	198.847	200.656	201.145	205.841	204.050	205.487
224	–	218.199	211.234	222.891	219.508	223.537	218.898	226.121	224.554	229.386	222.065
250	–	240.578	240.572	245.752	249.995	246.464	249.300	249.313	255.742	252.913	252.907
280	–	274.147	270.443	280.042	281.036	280.855	280.256	284.101	287.497	288.204	284.310
315	–	302.121	298.181	308.618	309.861	309.513	309.000	313.091	316.984	317.612	313.470
355	–	–	339.788	–	353.097	–	352.116	–	361.214	–	357.210
400	–	–	374.460	–	389.127	–	388.046	–	398.073	–	393.660

# Zahnradgetriebe

# Gear Units

# Réducteurs à engrenages

Ist-Übersetzungen  
Bauarten B2.., B3.., B4..  
Größen 15 - 26

Actual Ratios  
Types B2.., B3.., B4..  
Sizes 15 - 26

Rapports réels  
Types B2.., B3.., B4..  
Tailles 15 - 26

Ist-Übersetzungen i / Actual ratios i / Rapports réels i												
Getriebegrößen / Gear unit sizes / Tailles réducteurs												i <sub>N</sub>
15	16	17	18	19	20	21	22	23	24	25	26	
4.963	-	-	-	-	-	-	-	-	-	-	-	5.0
5.609	5.630	5.514	-	-	-	-	-	-	-	-	-	5.6
6.340	6.362	6.234	-	-	-	-	-	-	-	-	-	6.3
7.132	7.192	7.012	7.239	-	-	-	-	-	-	-	-	7.1
8.101	8.090	7.965	8.143	-	-	-	-	-	-	-	-	8.0
8.810	9.190	8.662	9.250	-	-	-	-	-	-	-	-	9.0
10.099	9.993	9.930	10.059	-	-	-	-	-	-	-	-	10
10.914	11.456	10.731	11.531	-	-	-	-	-	-	-	-	11.2
12.172	12.380	12.770	12.462	12.062	-	12.256	-	-	-	-	-	12.5
13.810	13.832	13.790	14.654	13.709	13.698	13.902	13.719	-	-	-	-	14
15.215	15.665	16.226	16.014	15.192	15.640	15.436	15.538	-	-	-	-	16
17.262	17.290	17.522	18.620	17.267	17.252	17.510	17.279	-	-	-	-	18
19.379	19.581	19.762	20.348	19.607	19.698	19.883	19.570	19.591	-	19.284	-	20
21.900	21.982	22.333	22.950	22.158	22.368	22.470	22.222	22.139	21.930	21.793	22.206	22.4
24.916	24.842	25.409	25.936	25.048	25.278	25.400	25.113	25.027	24.783	24.635	25.095	25
27.847	28.263	28.398	29.507	28.175	28.576	28.571	28.389	28.151	28.015	27.711	28.368	28
31.634	31.588	32.259	32.979	32.005	32.143	32.456	31.933	31.979	31.513	31.478	31.909	31.5
34.400	35.883	35.080	37.463	34.804	36.513	35.294	36.275	34.775	35.797	34.231	36.248	35.5
39.435	39.021	40.215	40.738	39.899	39.706	40.461	39.446	39.866	38.927	39.241	39.417	40
42.617	44.732	43.460	46.702	43.117	45.518	43.725	45.221	43.082	44.626	42.407	45.187	45
48.536	48.341	49.496	50.469	49.106	49.190	49.798	48.869	49.065	48.226	48.297	48.833	50
54.562	55.055	55.641	57.479	55.203	56.022	55.981	55.656	55.158	54.924	54.294	55.615	56
60.158	61.892	61.348	64.616	60.865	62.978	61.722	62.567	60.815	61.744	59.863	62.520	63
68.553	68.239	69.909	71.243	69.358	69.438	70.335	68.984	69.301	68.076	68.216	68.933	71
78.131	77.761	76.506	81.184	79.977	79.127	77.639	78.610	76.497	77.575	78.100	78.551	80
85.645	88.626	83.865	88.846	87.670	91.242	87.739	86.772	86.448	85.631	88.260	89.933	90
99.664	97.150	97.593	97.391	102.020	100.017	99.821	98.061	98.353	96.770	100.414	101.633	100
110.155	113.052	107.865	113.333	112.759	116.389	111.565	111.565	109.924	110.097	112.228	115.629	112
126.535	124.952	123.904	125.263	129.526	128.641	126.733	124.690	124.870	123.049	127.487	129.232	125
137.599	143.532	134.739	143.889	140.851	147.769	137.815	141.643	135.788	139.780	138.634	146.803	140
157.741	156.082	154.462	156.471	161.470	160.690	157.989	154.029	155.665	152.002	158.928	159.639	160
170.467	178.930	166.923	179.375	174.496	184.212	170.735	176.576	168.224	174.252	171.749	183.008	180
194.143	193.365	190.107	193.846	198.732	199.073	194.448	190.821	191.588	188.310	195.603	197.772	200
218.249	220.222	213.712	220.769	223.408	226.722	218.592	217.324	215.377	214.464	219.891	225.240	224
240.634	247.566	235.631	248.182	246.322	254.874	241.012	244.309	237.467	241.094	242.444	253.208	250
274.210	272.957	268.510	273.636	280.692	281.015	274.641	269.366	270.602	265.822	276.274	279.178	280
302.191	311.045	295.909	311.818	309.334	320.226	302.666	306.952	298.215	302.913	304.465	318.133	315
-	342.784	-	343.636	-	352.902	-	338.273	-	333.823	-	350.596	355
-	-	-	-	-	-	-	-	-	-	-	-	400

# Zahnradgetriebe

# Gear Units

# Réducteurs à engrenages

Zulässige radiale Zusatzkräfte an Abtriebswelle  $d_2$ <sup>1)</sup>  
Vollwelle (S)

Permissible Additional Radial Forces on Output Shaft  $d_2$ <sup>1)</sup>  
Solid Shaft (S)

Efforts radiaux extérieurs admissibles sur l'arbre de sortie  $d_2$ <sup>1)</sup>  
Arbre plein (S)

Kraftangriff auf Mitte Wellenende  
Application of force on centre of shaft end  
Application d'une force au milieu de l'arbre

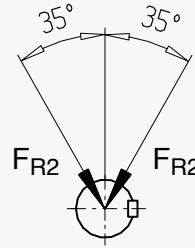
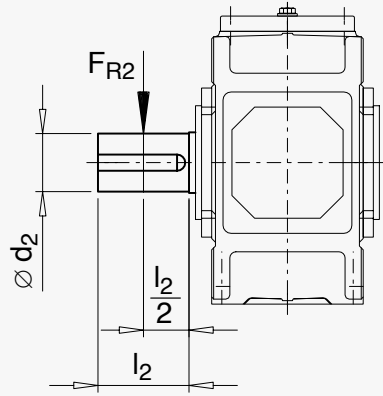

zulässige Krafrichtung  
Permissible direction of force  
Sens admissible des efforts

Tabelle / Table / Tableau 1

Zulässige radiale Zusatzkräfte  $F_{R2}$  in kN bei Kraftangriff Mitte Wellenende<sup>3)</sup>  
Permissible additional radial forces  $F_{R2}$  in kN with application of force on centre of shaft end<sup>3)</sup>  
Forces radiales supplémentaires radiales admissibles  $F_{R2}$  en kN appliquées au milieu du bout d'arbre<sup>3)</sup>

Bauart Type	Ausführung Design Version	Getriebegrößen / Gear unit sizes / Tailles réducteurs <sup>1) 4)</sup>															
		3	4	5	6	7	8	9	10	11	12	13	14	15	16	17	18
H1SH	A / B	2)	–	2)	–	2)	–	2)	–	2)	–	2)	–	2)	–	2)	–
H2S.	A / B / G / H	–	10	22	22	30	30	30	45	64	64	150	150	140	205	205	205
	C / D	–	10	13	13	18	18	10	28	35	35	112	112	85	135	135	135
B2S.	A / C	–	13	27	27	37	37	38	55	78	78	160	160	150	210	210	210
	B / D	–	12	15	15	17	17	10	30	35	38	110	110	75	145	100	100
H3S.	A / B / G / H	–	–	29	29	40	40	40	60	85	85	190	190	185	265	265	265
H4S.	C / D	–	–	–	–												
B3S.	A / C	–	14	29	29												
B4S.	A / C	–	–	–	–	26	26	18	40	50	50	150	150	120	185	185	190
H3S.	C / D	–	–	18	18												
H4S.	A / B	–	–	–	–												
B3S.	B / D	–	9	18	18												
B4S.	B / D	–	–	–	–												

Zulässige radiale Zusatzkräfte an Abtriebswelle  $d_2$  <sup>1)</sup>  
Vollwelle (S)

Permissible Additional Radial Forces on Output Shaft  $d_2$  <sup>1)</sup>  
Solid Shaft (S)

Efforts radiaux extérieurs admissibles sur l'arbre de sortie  $d_2$  <sup>1)</sup>  
Arbre plein (S)

**Kraftangriff außerhalb Mitte Wellenende**  
**Application of force outside the centre of the shaft end**  
**Application d'une force hors du milieu de l'arbre**

$F_{RZ2}$  Zulässige äußere Radialkraft  
Permissible external radial force  
Force radiale extérieure autorisée

$F_{R2}$  Zulässige radiale Zusatzkraft entsprechend Tabelle 1 Seite 58  
Permissible additional radial force acc. to table 1 page 58  
Force complémentaire radiale autorisée conformément au tableau 1 page 58

k Kraftangriffsfaktor entsprechend Tabelle  
Factor of application of force acc. to table  
Facteur d'application d'une force conformément au tableau

$$F_{RZ2} = F_{R2} \times k$$

**Tabelle / Table / Tableau 2**

**Kraftangriffsfaktor k / Factor of application of force k / Facteur d'application d'une force k**

Größe Size Taille	Abstand z in mm / Distance z in mm / Distance z en mm														
	- 200	- 150	- 100	- 75	- 50	- 25	0	25	50	75	100	150	200	250	300
<b>3</b>					1.21	1.09	1.00	0.85	0.74	0.65	0.58	0.48			
<b>4</b>					1.17	1.08	1.00	0.86	0.76	0.68	0.62	0.52	0.44		
<b>5 + 6</b>				1.22	1.14	1.06	1.00	0.88	0.79	0.72	0.66	0.56	0.49	0.43	
<b>7 + 8</b>				1.19	1.12	1.06	1.00	0.89	0.81	0.74	0.68	0.58	0.51	0.46	0.41
<b>9 + 10</b>			1.22	1.15	1.10	1.05	1.00	0.90	0.82	0.76	0.70	0.61	0.54	0.48	0.44
<b>11 + 12</b>			1.18	1.13	1.08	1.04	1.00	0.91	0.84	0.78	0.73	0.64	0.57	0.51	0.47
<b>13 + 14</b>		1.24	1.15	1.11	1.07	1.03	1.00	0.92	0.86	0.80	0.75	0.67	0.60	0.55	0.50
<b>15 + 16</b>		1.20	1.12	1.09	1.06	1.03	1.00	0.93	0.87	0.82	0.77	0.69	0.63	0.58	0.53
<b>17 + 18</b>	1.25	1.17	1.11	1.08	1.05	1.03	1.00	0.94	0.88	0.84	0.79	0.72	0.66	0.60	0.56

- 1) Tabellenwerte sind Mindestwerte, sie gelten für  $f_1 \geq 1.2$ . Unter Angabe von Angriffswinkel und Drehrichtung können meist bedeutend höhere Zusatzkräfte zugelassen werden.  
  
Rücksprache ist erforderlich.  
Gegebenfalls ist der Einsatz einer verstärkten Abtriebswelle (V) möglich.
- 2) Auf Anfrage
- 3) Bei Kraftangriff außerhalb Mitte Wellenende siehe Seite 59.
- 4) Fußschrauben mit Mindest-Festigkeitsklasse 8.8 verwenden.  
Fundament muß trocken und fettfrei sein.

- 1) Values in tables are minimum values. They are valid for  $f_1 \geq 1.2$ . If the angle of application of force and the direction of rotation are given, significantly higher additional forces can mostly be allowed.  
Please consult us.  
If necessary, a reinforced output shaft (V) can be used.
- 2) On request
- 3) For application of force outside the centre of the shaft end, see page 59.
- 4) Use foundation bolts of min. property class 8.8.  
Foundation must be dry and grease-free.

- 1) Les valeurs du tableau sont des valeurs minimales, elles sont valables pour  $f_1 \geq 1.2$ . Des forces additionnelles bien plus élevées peuvent être autorisées en indiquant l'angle d'application et le sens de rotation.  
Nous consulter.  
Éventuellement l'emploi d'un arbre de sortie renforcé (V) est possible.
- 2) Sur demande
- 3) Pour application d'une force hors du milieu de l'arbre, voir page 59.
- 4) Utiliser au minimum des vis de fixation de classe 8.8. Les fondations doivent être sèches et dégraissées.

- Auf Anfrage:**
- zulässige radiale Zusatzkräfte an Antriebswelle  $d_1$ .
  - zulässige radiale Zusatzkräfte an beidseitigen Abtriebsvollwellen (Ausführungen E, F und I).
  - zulässige radiale Zusatzkräfte für die Getriebegrößen 19 - 26

- On request:**
- Permissible additional radial forces on input shaft  $d_1$ .
  - Permissible additional radial forces on solid output shafts on both sides (assemblies E, F, and I).
  - Permissible additional radial forces for gear unit sizes 19 - 26.

- Sur demande:**
- efforts radiaux extérieurs admissibles sur l'arbre d'entrée  $d_1$ .
  - efforts radiaux extérieurs admissibles sur arbre plein des deux côtés (exécutions E, F, et I).
  - efforts radiaux extérieurs admissibles pour réducteurs tailles 19 - 26.

# Zahnradgetriebe

# Gear Units

# Réducteurs à engrenages

Massenträgheitsmomente  $J_1$   
 Bauarten H1..., H2..., H3..., H4..  
 Größen 3 - 14

Mass Moments of Inertia  $J_1$   
 Types H1..., H2..., H3..., H4..  
 Sizes 3 - 14

Moments d'inertie de masse  $J_1$   
 Types H1..., H2..., H3..., H4..  
 Tailles 3 - 14

Das auf Welle  $d_2$  eines Getriebes bezogene Massenträgheitsmoment  $J_2$  in  $\text{kgm}^2$  wird nach folgender Formel errechnet:  $J_2 = i_N^2 \times J_1$ . Die Massenträgheitsmomente  $J_1$  in  $\text{kgm}^2$  sind auf Welle  $d_1$  der Getriebe bezogen und gelten für Welle  $d_1$  ohne Lüfter.  
 Bei Welle  $d_1$  mit Lüfter ist  $J_L$  zu addieren.  
 Werte für Flanschwellengetriebe auf Anfrage.

The mass moment of inertia  $J_2$  in  $\text{kgm}^2$  refers to the output shaft  $d_2$  of a gear unit and is calculated with the following formula:  $J_2 = i_N^2 \times J_1$ . The mass moment of inertia  $J_1$  in  $\text{kgm}^2$  refers to the input shaft  $d_1$  of a gear unit without fan.  
 For shaft  $d_1$  with fan,  $J_L$  has to be added.  
 Values for gear units with flanged shaft on request.

Le moment d'inertie  $J_2$  en  $\text{kgm}^2$  ramené à l'arbre  $d_2$  d'un réducteur peut être approximativement calculé:  $J_2 = i_N^2 \times J_1$ . Les moments d'inertie  $J_1$  en  $\text{kgm}^2$  se rapportent aux arbres  $d_1$  des réducteurs sans ventilateur. La valeur  $J_L$  est à additionner pour les arbres  $d_1$  avec ventilateur. Valeur pour réducteur avec arbre bride, sur demande.

Massenträgheitsmomente  $J_1$  in  $\text{kgm}^2$  bezogen auf Welle  $d_1$  / Mass moments of inertia  $J_1$  in  $\text{kgm}^2$  referring to shaft  $d_1$   
 Moments d'inertie de masse  $J_1$  en  $\text{kgm}^2$  rapport à l'arbre  $d_1$

$i_N$	Getriebegrößen / Gear unit sizes / Tailles réducteurs											
	3	4	5	6	7	8	9	10	11	12	13	14
1.25	0.02855	-	0.15709	-	0.42300	-	0.92932	-	-	-	-	-
1.4	0.02589	-	0.14349	-	0.38558	-	0.84322	-	-	-	-	-
1.6	0.02243	-	0.12352	-	0.33519	-	0.72861	-	1.74977	-	3.74077	-
1.8	0.01974	-	0.10903	-	0.30515	-	0.66019	-	1.58798	-	3.22057	-
2.0	0.01820	-	0.09932	-	0.27747	-	0.59704	-	1.43757	-	2.90582	-
2.24	0.01677	-	0.09029	-	0.23964	-	0.53840	-	1.29698	-	2.61258	-
2.5	0.01479	-	0.08187	-	0.21652	-	0.48366	-	1.16495	-	2.33813	-
2.8	0.01347	-	0.07398	-	0.20156	-	0.44378	-	1.04055	-	2.08042	-
3.15	0.00915	-	0.05006	-	0.14031	-	0.31089	-	0.84211	-	1.67273	-
3.55	0.00807	-	0.04369	-	0.12256	-	0.27320	-	0.73595	-	1.47399	-
4.0	0.00702	-	0.03797	-	0.10584	-	0.23756	-	0.64640	-	1.28613	-
4.5	0.00522	-	0.02975	-	0.08623	-	0.19980	-	0.49550	-	0.96567	-
5.0	0.00451	-	0.02756	-	0.07492	-	0.17089	-	0.40618	-	0.89360	-
5.6	0.00384	-	0.02332	-	0.06407	-	0.14114	-	0.37471	-	0.75803	-
$J_L$	0.060	-	0.045	-	0.100	-	0.100	-	0.290	-	0.290	-
6.3	-	0.01493	0.03380	-	0.09209	-	0.20124	-	0.52103	-	1.10195	-
7.1	-	0.01340	0.02812	-	0.07563	-	0.16652	-	0.45488	-	0.95997	-
8.0	-	0.01138	0.02503	0.03969	0.06630	0.11062	0.14592	0.23956	0.39684	0.63968	0.83523	1.28897
9.0	-	0.01020	0.02227	0.03260	0.05805	0.08946	0.12771	0.19511	0.32236	0.55211	0.72509	1.11239
10	-	0.00860	0.01857	0.02877	0.05058	0.07759	0.11102	0.16927	0.27967	0.47606	0.62735	0.95870
11.2	-	0.00757	0.01619	0.02538	0.04457	0.06721	0.09506	0.14665	0.25168	0.37982	0.55925	0.82433
12.5	-	0.00527	0.01187	0.02089	0.03379	0.05794	0.07209	0.12624	0.19234	0.32553	0.42550	0.70636
14	-	0.00453	0.01013	0.01809	0.02691	0.05063	0.06102	0.10716	0.16348	0.29072	0.36723	0.62499
16	-	0.00384	0.00853	0.01340	0.02264	0.03872	0.05133	0.08159	0.13633	0.22357	0.31417	0.47348
18	-	0.00320	0.00758	0.01136	0.02005	0.03044	0.04385	0.06852	0.12189	0.18813	0.28054	0.40553
20	-	0.00276	0.00649	0.00949	0.01712	0.02542	0.04039	0.05722	0.10460	0.15546	0.23699	0.34428
22.4	-	0.00230	0.00550	0.00834	0.01578	0.02227	0.03414	0.04838	0.08840	0.13769	-	0.30627
25	-	-	-	0.00710	-	0.01888	-	0.04442	-	0.11733	-	0.25717
28	-	-	-	0.00598	-	0.01734	-	0.03728	-	0.09842	-	-
$J_L$	-	0.006	0.010	0.010	0.045	0.045	0.045	0.045	0.100	0.100	0.290	0.290
22.4	-	-	-	-	-	-	-	-	-	-	0.28093	-
25	-	-	0.00645	-	0.01629	-	0.03910	-	0.10272	-	0.22706	-
28	-	-	0.00536	-	0.01447	-	0.03237	-	0.08333	-	0.18629	0.29678
31.5	-	-	0.00474	0.00682	0.01209	0.01734	0.02874	0.04142	0.07242	0.11030	0.16244	0.23899
35.5	-	-	0.00418	0.00565	0.01070	0.01536	0.02550	0.03413	0.06284	0.08898	0.14149	0.19520
40	-	-	0.00343	0.00498	0.00888	0.01278	0.02129	0.03021	0.05440	0.07704	0.12303	0.16971
45	-	-	0.00301	0.00438	0.00782	0.01129	0.01874	0.02673	0.04799	0.06659	0.10672	0.14739
50	-	-	0.00228	0.00358	0.00570	0.00933	0.01359	0.02221	0.03603	0.05741	0.07610	0.12778
56	-	-	0.00194	0.00313	0.00487	0.00819	0.01162	0.01949	0.02835	0.05047	0.06432	0.11049
63	-	-	0.00163	0.00238	0.00413	0.00597	0.00982	0.01419	0.02386	0.03805	0.05428	0.07906
71	-	-	0.00123	0.00202	0.00324	0.00509	0.00738	0.01210	0.01900	0.02979	0.04221	0.06666
80	-	-	0.00102	0.00169	0.00278	0.00430	0.00624	0.01020	0.01595	0.02500	0.03866	0.05611
90	-	-	0.00088	0.00128	0.00229	0.00337	0.00520	0.00768	0.01453	0.01991	0.03176	0.04362
100	-	-	-	0.00106	-	0.00289	-	0.00648	-	0.01667	-	0.03992
112	-	-	-	0.00091	-	0.00238	-	0.00539	-	0.01517	-	0.03274
$J_L$	-	-	0.006	0.006	0.010	0.010	0.020	0.020	0.045	0.045	0.045	0.045
100	-	-	-	-	0.00328	-	0.00667	-	0.01753	-	0.03962	-
112	-	-	-	-	0.00274	-	0.00552	-	0.01560	-	0.03254	-
125	-	-	-	-	0.00243	0.00334	0.00486	0.00683	0.01310	0.01796	0.02873	0.04034
140	-	-	-	-	0.00202	0.00279	0.00428	0.00564	0.01164	0.01597	0.02534	0.03309
160	-	-	-	-	0.00176	0.00247	0.00348	0.00496	0.00970	0.01338	0.02087	0.02919
180	-	-	-	-	0.00153	0.00205	0.00300	0.00436	0.00848	0.01188	0.01806	0.02572
200	-	-	-	-	0.00124	0.00178	0.00230	0.00354	0.00595	0.00988	0.01339	0.02115
224	-	-	-	-	0.00097	0.00155	0.00195	0.00305	0.00508	0.00863	0.01135	0.01829
250	-	-	-	-	0.00081	0.00126	0.00163	0.00234	0.00428	0.00606	0.00948	0.01358
280	-	-	-	-	0.00065	0.00098	0.00134	0.00199	0.00354	0.00517	0.00794	0.01150
315	-	-	-	-	0.00060	0.00082	0.00112	0.00165	0.00304	0.00435	0.00670	0.00960
355	-	-	-	-	0.00050	0.00066	0.00097	0.00136	0.00252	0.00360	0.00559	0.00803
400	-	-	-	-	-	0.00060	-	0.00114	-	0.00309	-	0.00678
450	-	-	-	-	-	0.00050	-	0.00098	-	0.00256	-	0.00565



# Zahnradgetriebe

# Gear Units

# Réducteurs à engrenages

Massenträgheitsmomente  $J_1$   
 Bauarten H1..., H2..., H3..., H4..  
 Größen 15 - 26

Mass Moments of Inertia  $J_1$   
 Types H1..., H2..., H3..., H4..  
 Sizes 15 - 26

Moments d'inertie de masse  $J_1$   
 Types H1..., H2..., H3..., H4..  
 Tailles 15 - 26

Das auf Welle  $d_2$  eines Getriebes bezogene Massenträgheitsmoment  $J_2$  in  $\text{kgm}^2$  wird nach folgender Formel errechnet:  $J_2 = i_N^2 \times J_1$ . Die Massenträgheitsmomente  $J_1$  in  $\text{kgm}^2$  sind auf Welle  $d_1$  der Getriebe bezogen und gelten für Welle  $d_1$  ohne Lüfter.  
 Bei Welle  $d_1$  mit Lüfter ist  $J_L$  zu addieren.  
 Werte für Flanschwellengetriebe auf Anfrage.

The mass moment of inertia  $J_2$  in  $\text{kgm}^2$  refers to the output shaft  $d_2$  of a gear unit and is calculated with the following formula:  $J_2 = i_N^2 \times J_1$ . The mass moment of inertia  $J_1$  in  $\text{kgm}^2$  refers to the input shaft  $d_1$  of a gear unit without fan.  
 For shaft  $d_1$  with fan,  $J_L$  has to be added.  
 Values for gear units with flanged shaft on request.

Le moment d'inertie  $J_2$  en  $\text{kgm}^2$  ramené à l'arbre  $d_2$  d'un réducteur peut être approximativement calculé:  $J_2 = i_N^2 \times J_1$ . Les moments d'inertie  $J_1$  en  $\text{kgm}^2$  se rapportent aux arbres  $d_1$  des réducteurs sans ventilateur. La valeur  $J_L$  est à additionner pour les arbres  $d_1$  avec ventilateur. Valeur pour réducteur avec arbre bride, sur demande.

Massenträgheitsmomente $J_1$ in $\text{kgm}^2$ bezogen auf Welle $d_1$ / Mass moments of inertia $J_1$ in $\text{kgm}^2$ referring to shaft $d_1$ Moments d'inertie de masse $J_1$ en $\text{kgm}^2$ rapport à l'arbre $d_1$												
Getriebegrößen / Gear unit sizes / Tailles réducteurs												$i_N$
15	16	17	18	19	20	21	22	23	24	25	26	
-	-	-	-	-	-	-	-	-	-	-	-	1.25
-	-	-	-	-	-	-	-	-	-	-	-	1.4
-	-	-	-	-	-	-	-	-	-	-	-	1.6
-	-	-	-	-	-	-	-	-	-	-	-	1.8
6.86903	-	11.68172	-	21.86950	-	-	-	-	-	-	-	2.0
6.15225	-	10.37670	-	18.65867	-	-	-	-	-	-	-	2.24
5.52442	-	9.40145	-	16.67579	-	-	-	-	-	-	-	2.5
4.95982	-	8.44258	-	14.80399	-	-	-	-	-	-	-	2.8
3.91162	-	6.72168	-	11.98945	-	-	-	-	-	-	-	3.15
3.40747	-	5.86409	-	11.14244	-	-	-	-	-	-	-	3.55
2.93210	-	5.05491	-	9.52270	-	-	-	-	-	-	-	4.0
2.30308	-	4.00905	-	7.87489	-	-	-	-	-	-	-	4.5
1.96108	-	3.55977	-	6.66044	-	-	-	-	-	-	-	5.0
1.65759	-	3.01084	-	5.50473	-	-	-	-	-	-	-	5.6
0.690	-	0.690	-	0.690	-	-	-	-	-	-	-	$J_L$
2.69450	-	5.30249	-	10.62628	-	14.12289	-	24.64317	-	43.55254	-	6.3
2.36587	2.93445	4.38152	5.79425	9.32889	11.42554	12.30855	15.24965	21.27286	26.82051	38.24316	48.18357	7.1
2.07496	2.56276	3.85101	4.74843	8.17656	9.98029	10.71777	13.22687	18.34784	23.02087	33.54245	42.06256	8.0
1.81611	2.23558	3.37587	4.15070	7.14706	8.70419	9.31584	11.46160	15.79400	19.74133	27.44042	36.67561	9.0
1.58473	1.94622	2.94834	3.61890	6.27857	7.57118	8.14946	9.91374	13.98253	16.89503	23.90250	29.73863	10
1.37708	1.68919	2.56216	3.14368	5.52433	6.62132	7.14789	8.63265	12.28293	14.88773	20.72374	25.75162	11.2
1.14218	1.46006	2.04515	2.71748	4.44852	5.80139	5.67579	7.53848	9.55712	13.01466	16.62461	22.19542	12.5
0.97937	1.20991	1.76837	2.16566	3.81731	4.67000	4.86012	5.98802	8.17152	10.14205	15.30108	17.78037	14
0.82110	1.03247	1.51448	1.86457	3.23981	3.99197	4.12526	5.10635	6.92018	8.63279	12.85289	16.31922	16
0.68720	0.86324	1.21881	1.59010	2.59172	3.37526	3.27028	4.31621	5.53436	7.27791	10.75060	13.63177	18
0.56007	0.72007	1.10345	1.27695	2.24548	2.69238	2.81401	3.41219	4.94009	5.80643	9.00584	11.37655	20
-	0.58429	-	1.15512	-	2.32662	-	2.92840	-	5.17225	-	9.50042	22.4
-	-	-	-	-	-	-	-	-	-	-	-	25
-	-	-	-	-	-	-	-	-	-	-	-	28
0.290	0.290	0.690	0.690	0.690	0.690	0.690	0.690	0.690	0.690	0.690	0.690	$J_L$
0.74161	-	0.81650	-	1.65788	-	3.73410	-	5.04264	-	10.06130	-	22.4
0.60098	0.76346	0.65739	0.85893	1.33246	1.72711	3.03258	3.82925	4.01585	5.22093	8.05438	10.47078	25
0.52263	0.61732	0.56883	0.68913	1.15173	1.38384	2.63821	3.10389	3.44684	4.14947	6.43749	8.36280	28
0.45433	0.53601	0.49253	0.59483	0.99457	1.19361	2.29194	2.69673	2.95348	3.55649	5.53232	6.66760	31.5
0.36744	0.46523	0.39559	0.51371	0.85730	1.02850	1.98651	2.33968	2.52426	3.04293	4.74133	5.72028	35.5
0.31814	0.37536	0.34093	0.41097	0.73692	0.88457	1.71599	2.02518	2.14973	2.59672	4.04798	4.89375	40
0.28778	0.32445	0.30742	0.35319	0.65396	0.75863	1.47554	1.74703	1.82214	2.20791	3.43873	4.17049	45
0.21066	0.29316	0.22462	0.31786	0.46753	0.67202	1.20329	1.50020	1.48427	1.86835	2.73103	3.53614	50
0.17805	0.21496	0.18897	0.23297	0.39842	0.48071	1.01816	1.22342	1.23983	1.52199	2.31874	2.80661	56
0.14889	0.18145	0.15726	0.19556	0.33619	0.40895	0.86937	1.03395	1.04655	1.26941	1.95017	2.37908	63
0.12167	0.15152	0.13362	0.16237	0.28899	0.34446	0.69699	0.88189	0.80638	1.07002	1.47637	1.99761	71
0.10341	0.12385	0.11393	0.13785	0.24205	0.29606	0.55341	0.70676	0.63528	0.82469	1.34742	1.51283	80
0.08646	0.10516	0.09573	0.11733	0.19751	0.24759	0.50692	0.56061	0.57752	0.64877	1.11106	1.37982	90
-	0.08784	-	0.09841	-	0.20171	-	0.51330	-	0.58946	-	1.13627	100
-	-	-	-	-	-	-	-	-	-	-	-	112
0.100	0.100	0.100	0.100	-	-	-	-	-	-	-	-	$J_L$
0.10814	-	0.11315	-	0.23894	-	0.60939	-	0.68056	-	1.34533	-	100
0.08764	0.10910	0.09173	0.11518	0.19488	0.24222	0.52729	0.61425	0.58382	0.68966	1.15832	1.36329	112
0.07613	0.08829	0.07972	0.09324	0.16925	0.19732	0.45584	0.53127	0.50190	0.59128	0.99590	1.17296	125
0.06605	0.07672	0.06922	0.08096	0.14680	0.17125	0.36516	0.45909	0.39942	0.51001	0.85423	1.00776	140
0.05704	0.06652	0.05986	0.07022	0.12654	0.14842	0.31382	0.36751	0.34116	0.40382	0.73018	0.86376	160
0.04990	0.05742	0.05247	0.06066	0.10759	0.12785	0.28076	0.31570	0.30345	0.34468	0.64480	0.73776	180
0.03803	0.05022	0.03937	0.05313	0.08150	0.10862	0.21559	0.28235	0.23376	0.30645	0.48793	0.65111	200
0.02994	0.03828	0.03102	0.03991	0.06851	0.08231	0.18183	0.21687	0.19653	0.23615	0.41707	0.49254	224
0.02503	0.03013	0.02596	0.03140	0.05728	0.06915	0.15057	0.18284	0.16198	0.19842	0.35335	0.42075	250
0.02100	0.02517	0.02181	0.02626	0.04677	0.05779	0.12952	0.15135	0.13871	0.16344	0.31167	0.35624	280
0.01768	0.02111	0.01840	0.02206	0.04283	0.04716	0.10994	0.13017	0.11753	0.13993	0.26090	0.31414	315
0.01616	0.01777	0.01685	0.01859	0.03572	0.04318	0.09172	0.11046	0.09770	0.11850	0.20636	0.26284	355
-	0.01625	-	0.01702	-	0.03599	-	0.09213	-	0.09847	-	0.20782	400
-	-	-	-	-	-	-	-	-	-	-	-	450

## Zahnradgetriebe

## Gear Units

## Réducteurs à engrenages

Massenträgheitsmomente  $J_1$   
Bauarten B2..., B3..., B4..  
Größen 4 - 14

Mass Moments of Inertia  $J_1$   
Types B2..., B3..., B4..  
Sizes 4 - 14

Moments d'inertie de masse  $J_1$   
Types B2..., B3..., B4..  
Tailles 4 - 14

Das auf Welle  $d_2$  eines Getriebes bezogene Massenträgheitsmoment  $J_2$  in  $\text{kgm}^2$  wird nach folgender Formel errechnet:  $J_2 = i_N^2 \times J_1$ .  
Die Massenträgheitsmomente  $J_1$  in  $\text{kgm}^2$  sind auf Welle  $d_1$  der Getriebe bezogen und gelten für Welle  $d_1$  ohne Lüfter.

Bei Welle  $d_1$  mit Lüfter ist  $J_L$  zu addieren.  
Werte für Flanschwellengetriebe auf Anfrage.

The mass moment of inertia  $J_2$  in  $\text{kgm}^2$  refers to the output shaft  $d_2$  of a gear unit and is calculated with the following formula:  $J_2 = i_N^2 \times J_1$ .  
The mass moment of inertia  $J_1$  in  $\text{kgm}^2$  refers to the input shaft  $d_1$  of a gear unit without fan.

For shaft  $d_1$  with fan,  $J_L$  has to be added.  
Values for gear units with flanged shaft on request.

Le moment d'inertie  $J_2$  en  $\text{kgm}^2$  ramené à l'arbre  $d_2$  d'un réducteur peut être approximativement calculé:  $J_2 = i_N^2 \times J_1$ .

Les moments d'inertie  $J_1$  en  $\text{kgm}^2$  se rapportent aux arbres  $d_1$  des réducteurs sans ventilateur.  
La valeur  $J_L$  est à additionner pour les arbres  $d_1$  avec ventilateur. Valeur pour réducteur avec arbre bride, sur demande.

Massenträgheitsmomente  $J_1$  in  $\text{kgm}^2$  bezogen auf Welle  $d_1$  / Mass moments of inertia  $J_1$  in  $\text{kgm}^2$  referring to shaft  $d_1$   
Moments d'inertie de masse  $J_1$  en  $\text{kgm}^2$  rapport à l'arbre  $d_1$

$i_N$	Getriebegrößen / Gear unit sizes / Tailles réducteurs										
	4	5	6	7	8	9	10	11	12	13	14
5.0	0.03211	0.07501	–	0.20154	–	0.44627	–	1.29058	–	2.79496	–
5.6	0.03024	0.06915	–	0.17137	–	0.37934	–	1.08250	–	2.36141	–
6.3	0.02673	0.05791	0.08406	0.13819	0.23057	0.30248	0.50622	0.85265	1.48203	1.86785	3.10156
7.1	0.02249	0.04955	0.07668	0.11905	0.19554	0.25734	0.42923	0.73360	1.23242	1.63448	2.60149
8.0	0.01814	0.03799	0.06347	0.08858	0.15603	0.18973	0.33932	0.53110	0.96847	1.18384	2.05333
9.0	0.01486	0.03115	0.05410	0.07952	0.13365	0.17287	0.28749	0.48051	0.82632	1.06973	1.78297
10	0.01037	0.02538	0.04185	0.06883	0.09965	0.14614	0.21259	0.41113	0.60295	0.92751	1.29891
11.2	0.00931	0.02176	0.03406	0.05956	0.08888	0.12482	0.19220	0.35269	0.54127	0.80120	1.16704
12.5	–	–	0.02760	–	0.07596	–	0.16085	–	0.45737	–	1.00155
14	–	–	0.02366	–	0.06566	–	0.13741	–	0.39227	–	0.86460
$J_L$	0.020	0.045	0.045	0.100	0.100	0.100	0.100	0.290	0.290	0.690	0.690
12.5	0.00756	0.01615	–	0.04549	–	0.10285	–	0.27616	–	0.61844	–
14	0.00734	0.01575	–	0.04455	–	0.09999	–	0.26878	–	0.60537	–
16	0.00623	0.01371	0.01750	0.03768	0.04966	0.08727	0.11205	0.23571	0.30357	0.51600	0.66451
18	0.00610	0.01346	0.01695	0.03713	0.04831	0.08550	0.10750	0.23105	0.29302	0.50838	0.64618
20	0.00569	0.01248	0.01458	0.03464	0.04011	0.07999	0.09297	0.21547	0.25301	0.47566	0.54284
22.4	0.00527	0.01157	0.01422	0.03229	0.03933	0.07329	0.09015	0.18297	0.24635	0.40380	0.53216
25	0.00456	0.01073	0.01308	0.02828	0.03637	0.06097	0.08364	0.14675	0.22734	0.32054	0.49435
28	0.00394	0.00881	0.01206	0.02376	0.03369	0.05206	0.07633	0.12605	0.19285	0.27212	0.41936
31.5	0.00335	0.00730	0.01109	0.01922	0.02934	0.04011	0.06322	0.09389	0.15405	0.20094	0.33203
35.5	0.00271	0.00586	0.00911	0.01568	0.02463	0.03275	0.05390	0.08401	0.13203	0.18235	0.28152
40	0.00190	0.00416	0.00755	0.01100	0.01996	0.02660	0.04168	0.07225	0.09842	0.15335	0.20806
45	0.00177	0.00393	0.00605	0.00984	0.01624	0.02280	0.03393	0.06249	0.08784	0.13099	0.18837
50	0.00129	0.00301	0.00431	0.00812	0.01143	0.01784	0.02750	0.04683	0.07516	0.10268	0.15794
56	0.00105	0.00248	0.00405	0.00682	0.01020	0.01462	0.02357	0.03850	0.06498	0.08549	0.13492
63	0.00087	0.00207	0.00310	0.00589	0.00840	0.01242	0.01844	0.03265	0.04876	0.07262	0.10571
71	0.00067	0.00157	0.00256	0.00467	0.00705	0.00997	0.01509	0.02622	0.04002	0.05866	0.08789
80	–	–	0.00213	–	0.00607	–	0.01280	–	0.03390	–	0.07459
90	–	–	0.00162	–	0.00481	–	0.01027	–	0.02719	–	0.06017
$J_L$	0.006	0.010	0.010	0.020	0.020	0.045	0.045	0.100	0.100	0.290	0.290
80	–	0.00240	–	0.00589	–	0.01293	–	0.03573	–	0.08226	–
90	–	0.00227	–	0.00543	–	0.01193	–	0.03317	–	0.07518	–
100	–	0.00200	0.00244	0.00468	0.00600	0.01100	0.01317	0.02895	0.03644	0.06237	0.08339
112	–	0.00176	0.00230	0.00404	0.00551	0.00903	0.01212	0.02431	0.03375	0.05320	0.07613
125	–	0.00145	0.00202	0.00344	0.00474	0.00749	0.01114	0.01969	0.02939	0.04108	0.06307
140	–	0.00117	0.00178	0.00278	0.00409	0.00600	0.00915	0.01603	0.02467	0.03348	0.05377
160	–	0.00091	0.00147	0.00195	0.00348	0.00427	0.00759	0.01127	0.01999	0.02716	0.04157
180	–	0.00085	0.00118	0.00181	0.00281	0.00402	0.00608	0.01007	0.01626	0.02328	0.03385
200	–	0.00058	0.00092	0.00132	0.00198	0.00308	0.00433	0.00830	0.01145	0.01821	0.02744
224	–	0.00047	0.00086	0.00108	0.00183	0.00254	0.00407	0.00696	0.01021	0.01491	0.02352
250	–	0.00043	0.00058	0.00090	0.00134	0.00211	0.00312	0.00600	0.00841	0.01266	0.01840
280	–	0.00033	0.00047	0.00069	0.00109	0.00160	0.00257	0.00476	0.00705	0.01016	0.01506
315	–	0.00028	0.00043	0.00058	0.00091	0.00136	0.00214	0.00405	0.00608	0.00812	0.01278
355	–	–	0.00034	–	0.00070	–	0.00162	–	0.00482	–	0.01025
400	–	–	0.00028	–	0.00059	–	0.00138	–	0.00409	–	0.00820

## Zahnradgetriebe

## Gear Units

## Réducteurs à engrenages

Massenträgheitsmomente  $J_1$   
Bauarten B2.., B3.., B4..  
Größen 15 - 26

Mass Moments of Inertia  $J_1$   
Types B2.., B3.., B4..  
Sizes 15 - 26

Moments d'inertie de masse  $J_1$   
Types B2.., B3.., B4..  
Tailles 15 - 26

Das auf Welle  $d_2$  eines Getriebes bezogene Massenträgheitsmoment  $J_2$  in  $\text{kgm}^2$  wird nach folgender Formel errechnet:  $J_2 = i_N^2 \times J_1$ . Die Massenträgheitsmomente  $J_1$  in  $\text{kgm}^2$  sind auf Welle  $d_1$  der Getriebe bezogen und gelten für Welle  $d_1$  ohne Lüfter.

Bei Welle  $d_1$  mit Lüfter ist  $J_L$  zu addieren.  
Werte für Flanschwellengetriebe auf Anfrage.

The mass moment of inertia  $J_2$  in  $\text{kgm}^2$  refers to the output shaft  $d_2$  of a gear unit and is calculated with the following formula:  $J_2 = i_N^2 \times J_1$ . The mass moment of inertia  $J_1$  in  $\text{kgm}^2$  refers to the input shaft  $d_1$  of a gear unit without fan.

For shaft  $d_1$  with fan,  $J_L$  has to be added.  
Values for gear units with flanged shaft on request.

Le moment d'inertie  $J_2$  en  $\text{kgm}^2$  ramené à l'arbre  $d_2$  d'un réducteur peut être approximativement calculé:  $J_2 = i_N^2 \times J_1$ .

Les moments d'inertie  $J_1$  en  $\text{kgm}^2$  se rapportent aux arbres  $d_1$  des réducteurs sans ventilateur. La valeur  $J_L$  est à additionner pour les arbres  $d_1$  avec ventilateur. Valeur pour réducteur avec arbre bride, sur demande.

Massenträgheitsmomente $J_1$ in $\text{kgm}^2$ bezogen auf Welle $d_1$ / Mass moments of inertia $J_1$ in $\text{kgm}^2$ referring to shaft $d_1$ Moments d'inertie de masse $J_1$ en $\text{kgm}^2$ rapport à l'arbre $d_1$												
Getriebegrößen / Gear unit sizes / Tailles réducteurs												$i_N$
15	16	17	18	19	20	21	22	23	24	25	26	
6.25795	–	–	–	–	–	–	–	–	–	–	–	5.0
5.40648	6.66677	10.37011	–	–	–	–	–	–	–	–	–	5.6
4.49760	5.72660	8.58657	–	–	–	–	–	–	–	–	–	6.3
3.77001	4.74810	7.14219	9.06446	–	–	–	–	–	–	–	–	7.1
2.78214	3.96800	5.01824	7.51989	–	–	–	–	–	–	–	–	8.0
2.53133	2.93557	4.52494	5.31094	–	–	–	–	–	–	–	–	9.0
2.16711	2.66107	3.85677	4.77245	–	–	–	–	–	–	–	–	10
1.81377	2.26584	3.32075	4.04511	–	–	–	–	–	–	–	–	11.2
–	1.89831	–	3.48202	–	–	–	–	–	–	–	–	12.5
–	–	–	–	–	–	–	–	–	–	–	–	14
0.690	0.690	0.690	0.690	–	–	–	–	–	–	–	–	$J_L$
1.69718	–	3.48560	–	7.8896	–	8.3877	–	–	–	–	–	12.5
1.65740	1.76004	3.44624	3.60423	7.7305	8.0659	8.2186	8.6052	–	–	–	–	14
1.48103	1.70973	3.06690	3.54418	6.9989	7.8400	7.4408	8.3643	–	–	–	–	16
1.45557	1.52126	3.04252	3.14038	6.8398	6.9560	7.2717	7.4142	–	–	–	–	18
1.37309	1.48906	2.88266	3.10318	6.37936	6.8399	6.79596	7.2972	13.03215	–	16.34176	–	20
1.14711	1.39966	2.43009	2.93035	5.50155	6.46478	5.82775	6.91637	10.99213	13.25774	13.58363	16.83295	22.4
0.90256	1.16792	1.92090	2.46743	4.57199	5.56843	4.82726	5.92204	9.07333	11.16877	11.10130	13.96823	25
0.77356	0.91864	1.67696	1.94976	3.82881	4.62433	4.03056	4.90105	7.52690	9.21156	9.12970	11.40227	28
0.56206	0.78643	1.21675	1.70005	2.82771	3.87017	2.98405	4.08888	5.31637	7.63615	6.55845	9.36758	31.5
0.50670	0.57204	1.09757	1.23465	2.56986	2.85976	2.70207	3.02924	4.77705	5.40103	5.82741	6.74279	35.5
0.43106	0.51513	0.94869	1.11270	2.19643	2.59697	2.29704	2.74029	4.04861	4.84864	4.84785	5.98329	40
0.36975	0.43748	0.81933	0.96021	1.83887	2.21706	1.92502	2.32612	3.48501	4.10309	4.16938	4.96647	45
0.27673	0.37524	0.57171	0.82919	1.40288	1.85654	1.46929	1.94992	2.60969	3.53166	3.13732	4.27095	50
0.22863	0.28096	0.46952	0.57931	1.14615	1.41650	1.19871	1.48849	2.12784	2.64566	2.54535	3.21563	56
0.19582	0.23198	0.40563	0.47553	1.04477	1.15693	1.08801	1.21390	1.85969	2.15630	2.20313	2.60731	63
0.15881	0.19858	0.33347	0.41058	0.84654	1.05364	0.87983	1.10050	1.50642	1.88310	1.77090	2.25410	71
–	0.16093	–	0.33728	–	0.85337	–	0.88945	–	1.52444	–	1.81015	80
–	–	–	–	–	–	–	–	–	–	–	–	90
0.290	0.290	0.690	0.690	0.690	0.690	0.690	0.690	0.690	0.690	0.690	0.690	$J_L$
0.22213	–	0.22783	–	0.49622	–	1.41079	–	1.52207	–	3.15981	–	80
0.18851	0.22377	0.19326	0.23101	0.42091	0.50136	1.17663	1.41869	1.26377	1.53687	2.64711	3.18972	90
0.15085	0.18988	0.15435	0.19590	0.33318	0.42519	0.92537	1.18281	0.99269	1.27536	2.08857	2.67053	100
0.12941	0.15185	0.13227	0.15630	0.28247	0.33633	0.79182	0.93015	0.84571	1.00164	1.81118	2.10666	112
0.09644	0.13023	0.09861	0.13387	0.20878	0.28505	0.57621	0.79564	0.61798	0.85288	1.32077	1.82566	125
0.08616	0.09706	0.08799	0.09982	0.18898	0.21073	0.51866	0.57917	0.55398	0.62353	1.18553	1.33199	140
0.07389	0.08669	0.07528	0.08902	0.15840	0.19063	0.44016	0.52117	0.46704	0.55868	1.01562	1.19502	160
0.06389	0.07429	0.06509	0.07606	0.13531	0.15966	0.37754	0.44207	0.40055	0.47061	0.87664	1.02284	180
0.04791	0.06423	0.04883	0.06575	0.10601	0.13639	0.28273	0.37918	0.30048	0.40361	0.59852	0.88283	200
0.03935	0.04818	0.04008	0.04935	0.08813	0.10684	0.23338	0.28399	0.24742	0.30284	0.50448	0.62066	224
0.03335	0.03956	0.03395	0.04049	0.07479	0.08879	0.19973	0.23438	0.21128	0.24929	0.43439	0.50825	250
0.02676	0.03353	0.02723	0.03429	0.06032	0.07533	0.16181	0.20055	0.17071	0.21282	0.35562	0.43750	280
0.02169	0.02690	0.02207	0.02748	0.04934	0.06074	0.12885	0.16245	0.13618	0.17189	0.28657	0.35801	315
–	0.02180	–	0.02228	–	0.04968	–	0.12937	–	0.13715	–	0.28854	355
–	–	–	–	–	–	–	–	–	–	–	–	400

# Zahnradgetriebe

# Gear Units

# Réducteurs à engrenages

Ausführungsformen

Assemblies

Exécutions

3

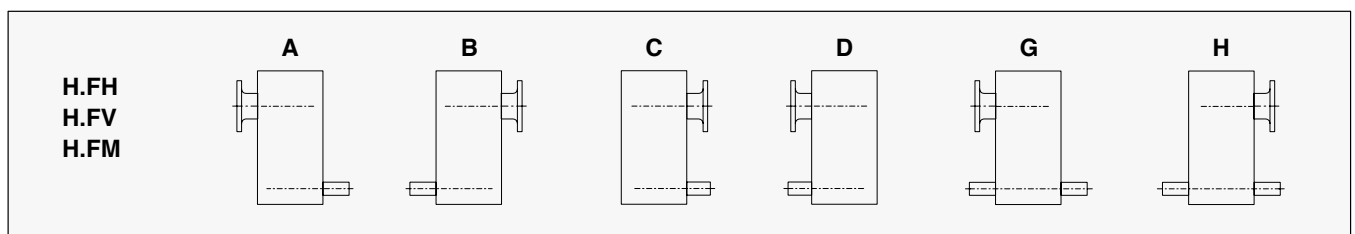
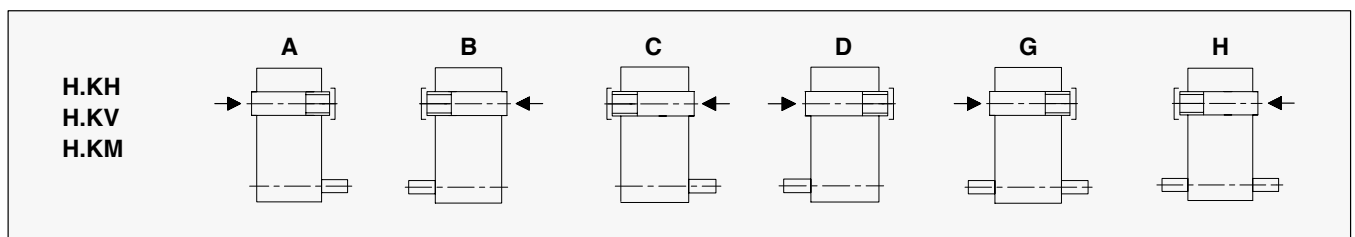
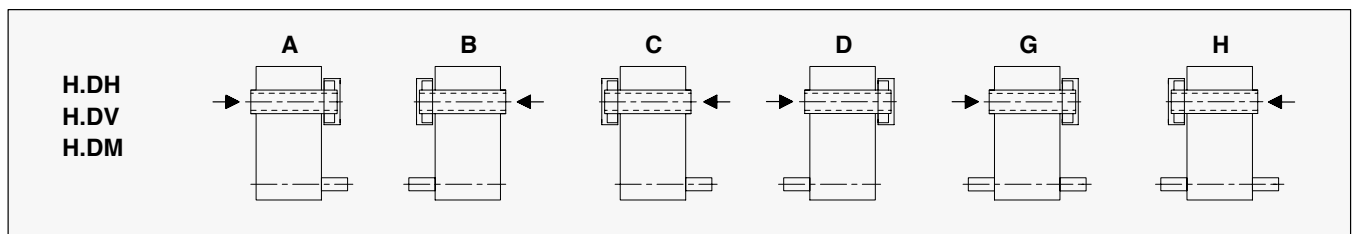
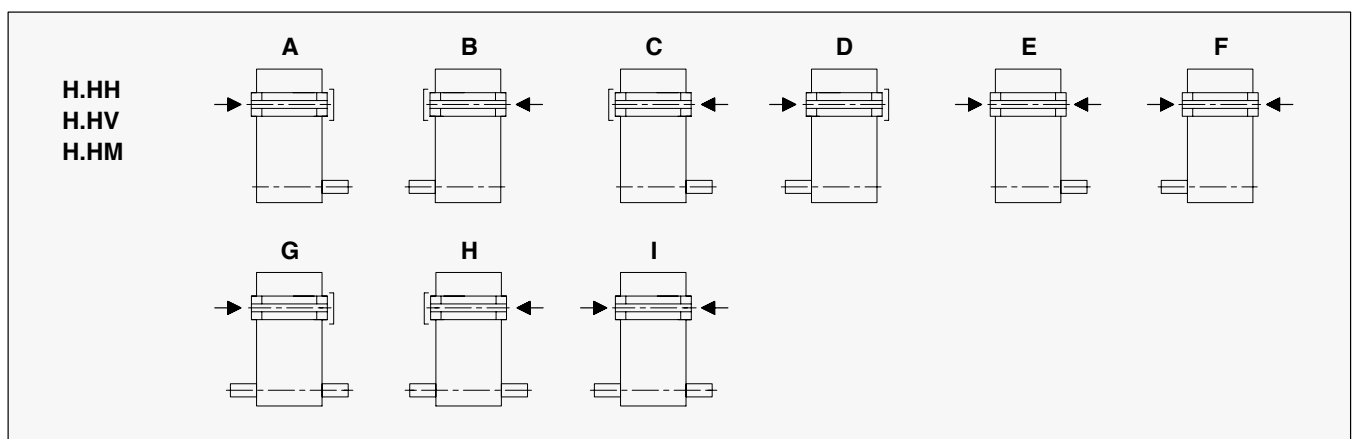
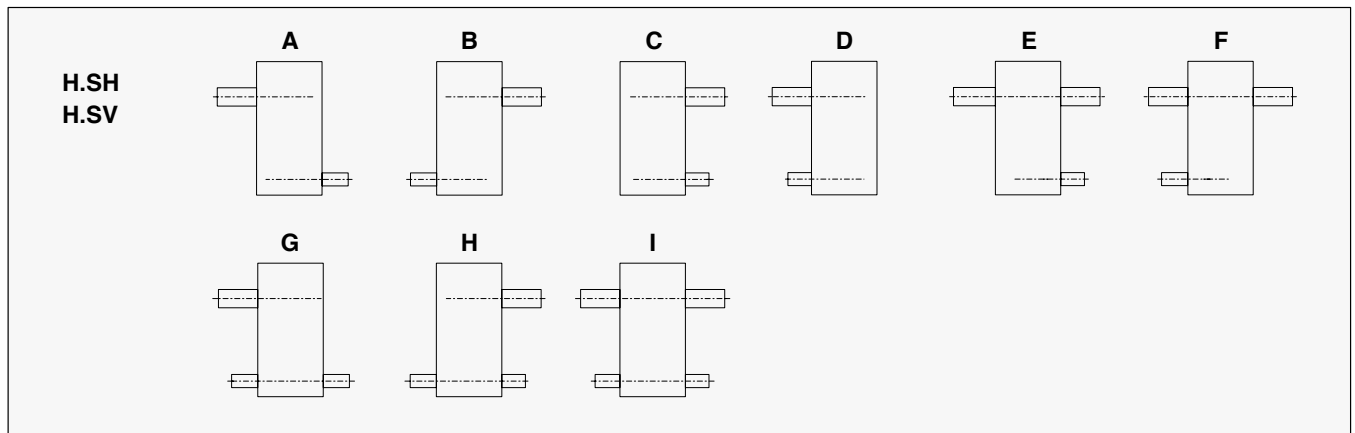

→ Pfeil kennzeichnet die Einführrichtung der Arbeitsmaschinenwelle  
 The arrow indicates the direction of insertion of the driven machine shaft  
 La flèche indique le sens d'insertion de l'arbre machine

# Zahnradgetriebe

# Gear Units

# Réducteurs à engrenages

Ausführungsformen  
Anbauseiten  
Getriebeneigung

Assemblies  
Attachment Side  
Gear Unit Inclination

Exécutions  
Côté du montage  
Inclinaison réducteur

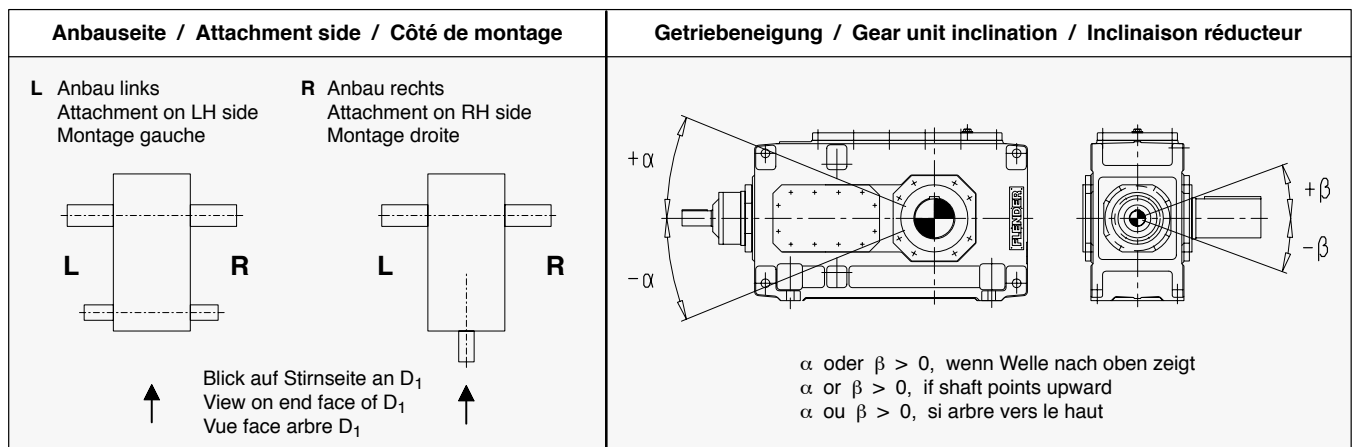
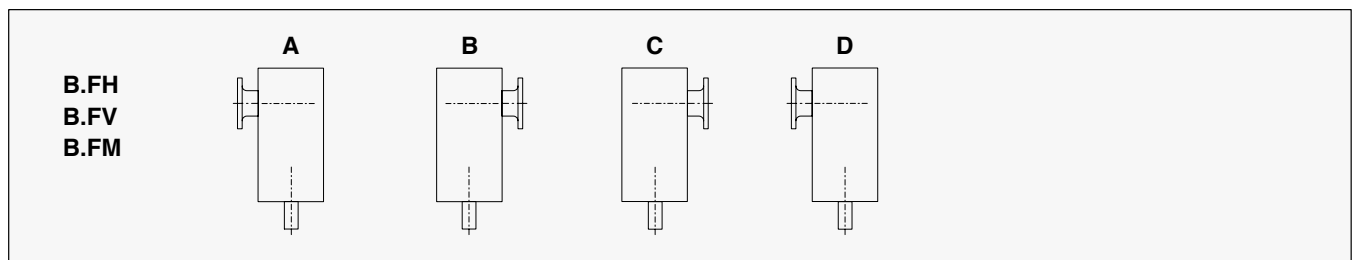
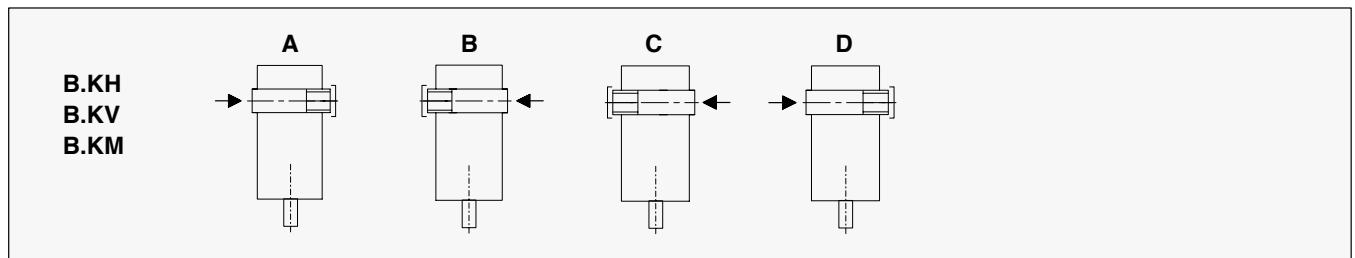
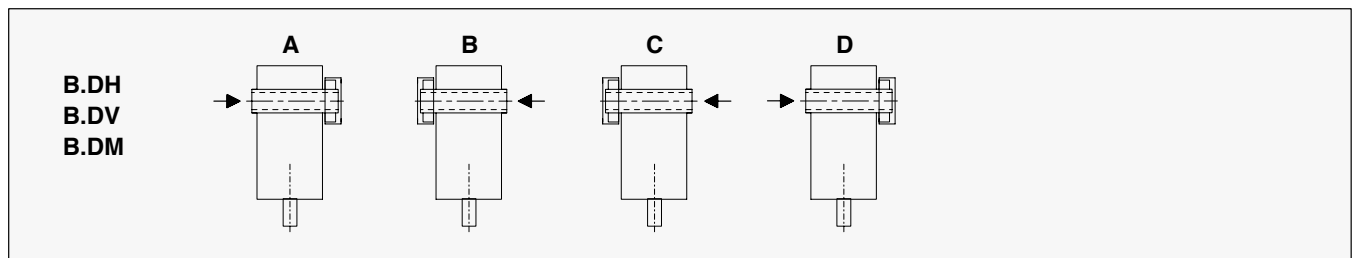
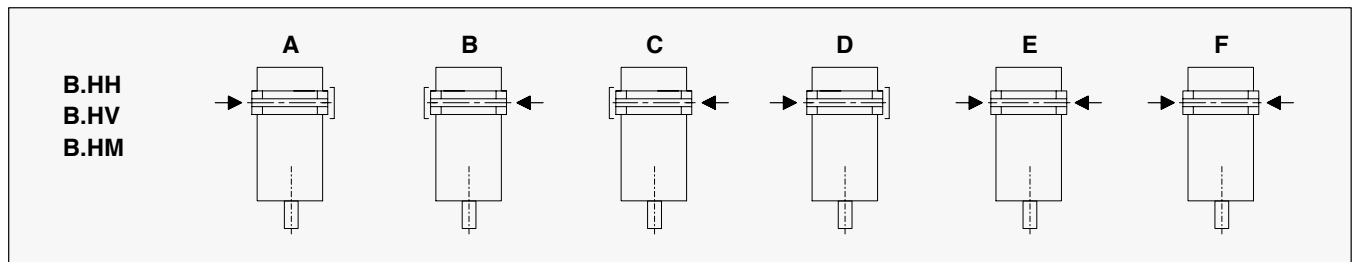
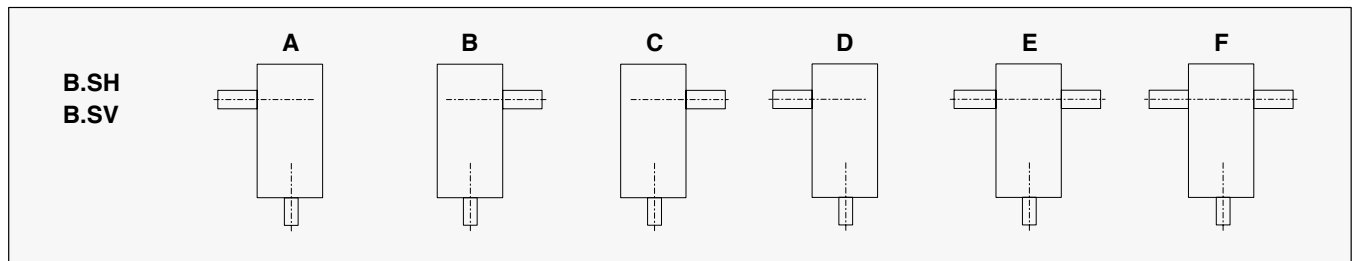

3

# Zahnradgetriebe

Einstufig  
Horizontal  
Bauart H1SH  
Größen 3 - 19

# Gear Units

Single Stage  
Horizontal  
Type H1SH  
Sizes 3 - 19

# Réducteurs à engrenages

à un train  
Horizontal  
Type H1SH  
Tailles 3 - 19

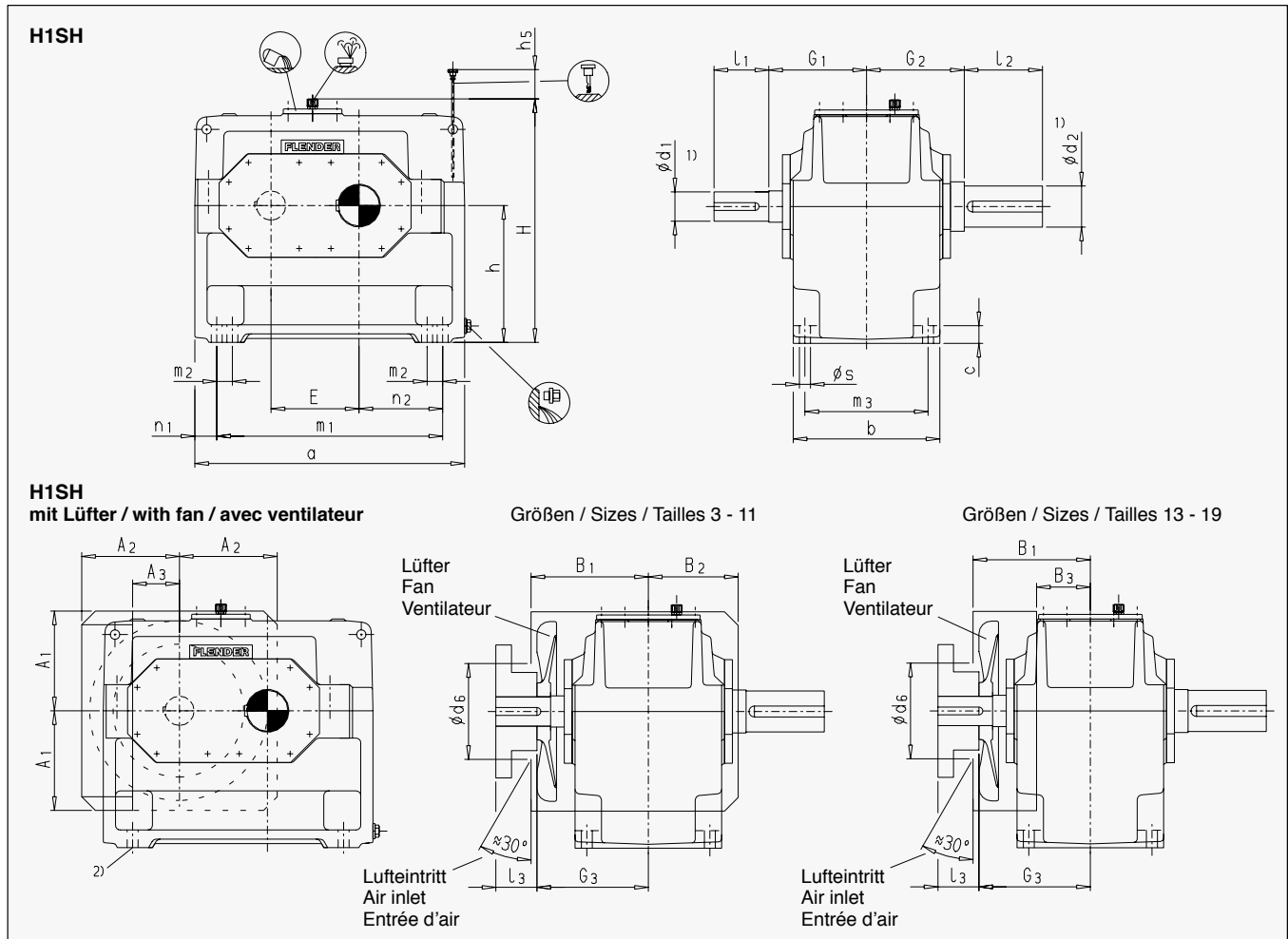

4

Größe Size Taille	Antrieb / Input / Entrée										Lüfter / Fan / Ventilateur							
	$i_N = 1.25 - 2.8$			$i_N = 3.15 - 4$			$i_N = 4.5 - 5.6$											
	$i_N = 1.6 - 2.8^{+)}$									$G_1$	$G_3$	$A_1$	$A_2$	$A_3$	$B_1$	$B_2$	$B_3$	$d_6$
	$d_1$	$l_1$	$l_3$	$d_1$	$l_1$	$l_3$	$d_1$	$l_1$	$l_3$	$G_1$	$G_3$	$A_1$	$A_2$	$A_3$	$B_1$	$B_2$	$B_3$	$d_6$
3	60	125	105	45	100	80	32	80	60	170	190	150	145	80	205	130	-	130
5	85	160	130	60	135	105	50	110	80	210	240	225	215	115	255	185	-	190
7	100	200	165	75	140	105	60	140	105	250	285	255	250	120	300	230	-	245
9	110	200	165	90	165	130	75	140	105	280	315	300	265	140	330	265	-	280
11 <sup>+) </sup>	130	240	205	110	205	170	90	170	135	325	360	360	330	190	375	320	-	350
13 <sup>+) </sup>	150	245	200	130	245	200	100	210	165	365	410	415	350	-	430	-	150	350
15 <sup>++) </sup>	180	290	240	150	250	200	125	250	200	360	410	500	430	-	430	-	120	450
17 <sup>++) </sup>	200	330	280	170	290	240	140	250	200	400	450	550	430	-	470	-	150	445
19 <sup>++) </sup>	220	340	290	190	340	290	160	300	250	440	490	630	475	-	510	-	190	445

Größe Size Taille	Zahnradgetriebe / Gear units / Réducteurs à engrenages												
	a	b	c	E	$h_{-1}$	$h_5$	H	$m_1$	$m_2$	$m_3$	$n_1$	$n_2$	s
3	420	200	28	130	200	85	375	310	-	160	55	110	19
5	580	285	35	185	290	100	525	440	-	240	70	160	24
7	690	375	45	225	350	75	625	540	-	315	75	195	28
9	805	425	50	265	420	50	735	625	-	350	90	225	35
11	960	515	60	320	500	40	875	770	-	440	95	280	35
13	1100	580	70	370	580	40	1020	870	-	490	115	315	42
15	1295	545	80	442	600	10	1115	1025	-	450	135	370	48
17	1410	615	80	490	670	-	1235	1170	130	530	120	425	42
19	1590	690	90	555	760	-	1395	1290	150	590	150	465	48

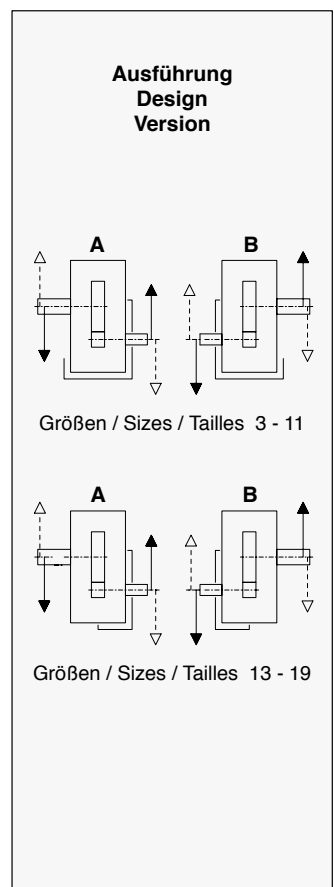

# Zahnradgetriebe

Einstufig  
Horizontal  
Bauart H1SH  
Größen 3 - 19

# Gear Units

Single Stage  
Horizontal  
Type H1SH  
Sizes 3 - 19

# Réducteurs à engrenages

à un train  
Horizontal  
Type H1SH  
Tailles 3 - 19

## Abtrieb / Output / Sortie

**H1SH**  
Vollwelle  
Solid shaft  
Arbre plein

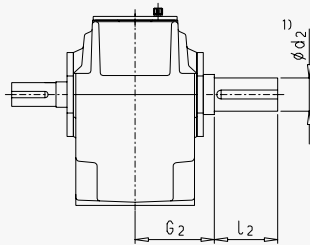

Größe Size Taille	H1SH		
	d <sub>2</sub>	l <sub>2</sub>	G <sub>2</sub>
3	60	125	170
5	85	160	210
7	105	200	250
9	125	210	270
11	150	240	320
13	180	310	360
15	220	350	360
17	240	400	400
19	270	450	440

Größe Size Taille	Ölmenge / Oil quantity Quantité de huile (l) *)		Gewicht Weight Poids (kg) *) **)	Kühlschlange / Cooling coil Serpentin de refroidissement		Abtrieb / Output / Sortie	Größe Size Taille				
	Wellen- dichtung Shaft seal Joint à lèvres	Labyrinth- dichtung Labyrinth seal Etanchéité à labyrinthe		b <sub>10</sub>	e <sub>10</sub>		h <sub>10</sub>	l/min x)			
3	7	5.2	128				3	48	205	74	4
5	22	18	302				5	88	270	90	4
7	42	34	547				7	124	310	135	4
9	68	57	862				9	116	365	110	8
11	120	100	1515				11	146	425	130	8
13	175	155	2395				13	152	480	150	8
15	190	156	3200				15	172	560	130	8
17	270	225	4250				17	202	600	145	8
19	390	330	5800				19	Auf Anfrage / On request Sur demande			

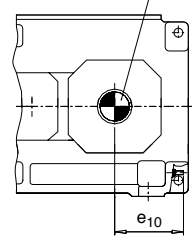
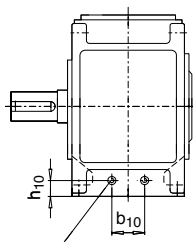

Wasseranschluß für Kühl-  
schlange G1/2"  
Water connection for cool-  
ing coil G1/2"  
Adduction pour serpent  
de refroidissement G1/2"

Kühlschlange geeignet für Süß-, See- und Brackwasser  
Cooling coil suitable for fresh, sea and brackish water  
Serpentin de refroidissement adapté à l'eau douce, de  
mer et saumâtre

x) Erforderliche Kühlwassermenge, max. Kühlwasserdruck: 8 bar / Cooling water  
quantity required, max. cooling water pressure: 8 bar / Quantité d'eau de re-  
froidissement nécessaire, pression maxi de l'eau de refroidissement: 8 bar

### Abmessungen in mm

#### 1) Wellen:

- m<sub>6</sub> ≤ Ø 100; n<sub>6</sub> > Ø 100
- Paßfedernut nach DIN 6885/1, Nabennutbreite nach ISO JS9
- Paßfeder nach DIN 6885/1 Form B
- Einzelheiten siehe Seiten 126 - 135

2) Vor dem Befestigen der Fußschrauben ist die Luftleithaube zu entfernen.

\*) Richtwerte; genaue Angaben nach auftrags-  
bezogener Dokumentation.  
Wellenabdichtungen siehe Seiten 158 - 160

\*\*) ohne Ölfüllung

### Dimensions in mm

#### 1) Shafts:

- m<sub>6</sub> ≤ Ø 100; n<sub>6</sub> > Ø 100
- Keyway acc. to DIN 6885/1, Hub keyway width acc. to ISO JS9
- Parallel key acc. to DIN 6885/1 form B
- For details, see pages 126 - 135

2) Remove air guide cover before fitting the foundation bolts.

\*) Approximate values; exact data acc. to order-  
related documentation.  
For shaft seals, see pages 158 - 160

\*\*) Without oil filling

### Dimensions en mm

#### 1) Arbres:

- m<sub>6</sub> ≤ Ø 100; n<sub>6</sub> > Ø 100
- Rainure de clavette selon DIN 6885/1, Tolérance dans le moyeu selon ISO JS9
- Clavette selon DIN 6885/1 forme B
- Détails voir pages 126 - 135

2) Pour la mise en place des vis / écrous, enlever le capot du ventilateur

\*) Valeurs approximatives; données exactes  
selon documentation relative à la commande.  
Etanchéités par labyrinthes voir pages 158 - 160

\*\*) sans huile



# Zahnradgetriebe

Zweistufig  
Horizontal  
Bauart H2.H  
Größen 4 - 12

# Gear Units

Two Stage  
Horizontal  
Type H2.H  
Sizes 4 - 12

# Réducteurs à engrenages

à deux trains  
Horizontal  
Type H2.H  
Tailles 4 - 12

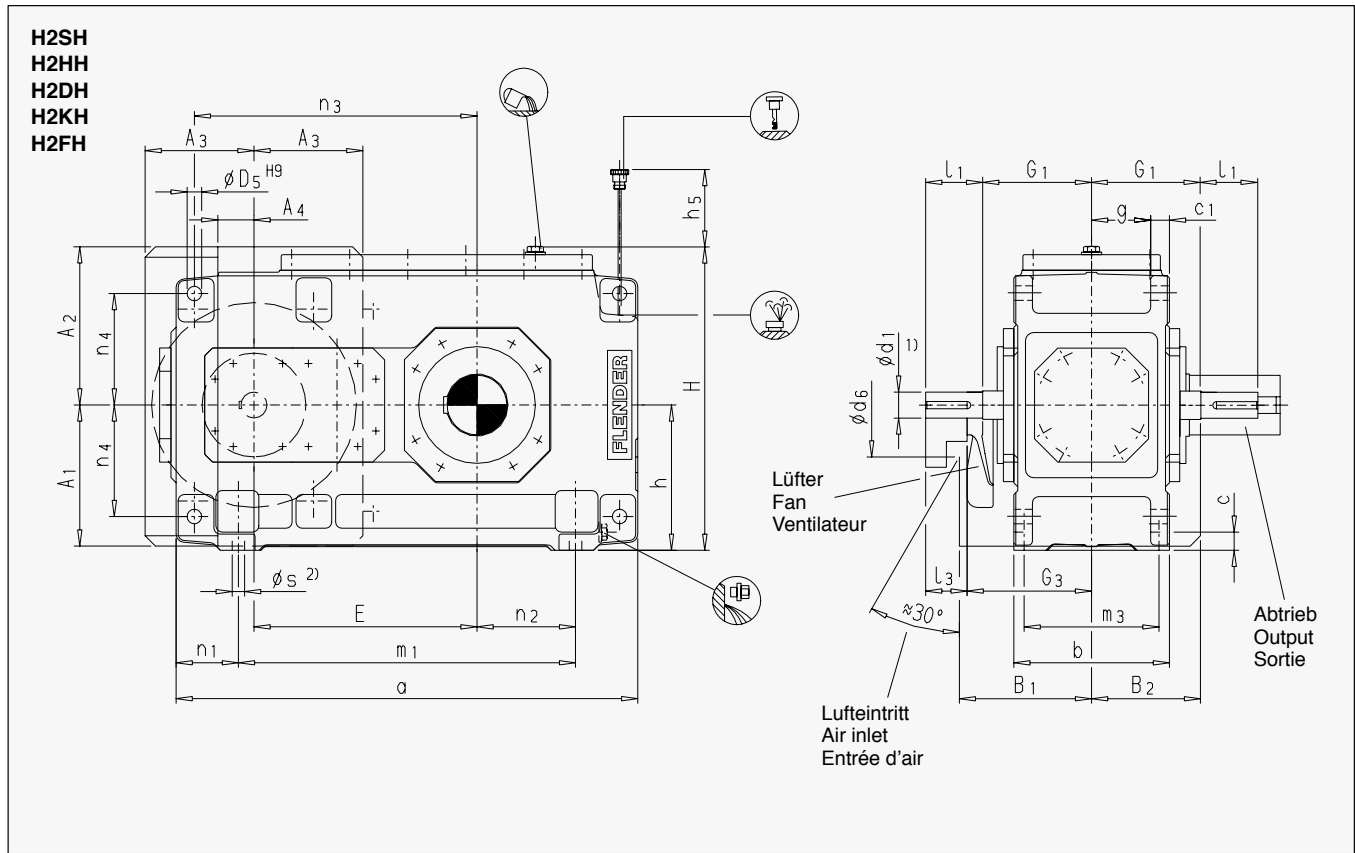

Größe Size Taille	Antrieb / Input / Entrée						Ausführung / Design Version G, H, I nur für / only for seulement pour $i_N =$		Lüfter / Fan / Ventilateur								
	$i_N = 6.3 - 11.2$			$i_N = 12.5 - 22.4$					$G_1$	$G_3$	$A_1$	$A_2$	$A_3$	$A_4$	$B_1$	$B_2$	$d_6$
	$d_1$	$l_1$	$l_3$	$d_1$	$l_1$	$l_3$											
4	45	100	80	32	80	60	170	190	6.3 - 18		195	225	150	30	205	158	136
5 + 6	50	100	80	38	80	60	195	215	6.3 - 18	8 - 22.4	225	260	175	55	230	178	150
7 + 8	60	135	105	50	110	80	210	240	6.3 - 16	8 - 20	272	305	210	70	255	210	200
9 + 10	75	140	110	60	140	110	240	270	6.3 - 16	8 - 20	312	355	240	100	285	245	200
11 + 12	90	165	130	70	140	105	275	310	6.3 - 18	8 - 22.4	372	420	285	135	325	285	210

Größe Size Taille	Zahnradgetriebe / Gear units / Réducteurs à engrenages									
	b	c	$c_1$	$D_5$	g	$h_{-1}$	$m_3$	$n_1$	$n_4$	s
4	215	28	$30 \pm 1$	24	77.5	200	180	105	150	19
5 + 6	255	28	$30 \pm 1$	24	97.5	230	220	105	180	19
7 + 8	300	35	$36 \pm 1$	28	114	280	260	120	215	24
9 + 10	370	40	$45 \pm 1.5$	36	140	320	320	145	245	28
11 + 12	430	50	$54 \pm 1.5$	40	161	380	370	165	300	35

Größe Size Taille	Zahnradgetriebe / Gear units / Réducteurs à engrenages								Rücklaufsperre Backstop / Anti-dévi- vireur $G_8^{+}$
	a	E	$h_5$	H	$m_1$	$n_2$	$n_3$		
4	565	270	110	415	355	85	345	207	
5	640	315	150	482	430	100	405	253	
6	720	350	150	482	510	145	440	253	
7	785	385	190	572	545	130	500	280	
8	890	430	190	582	650	190	545	280	
9	925	450	205	662	635	155	585	331	
10	1025	500	215	662	735	205	635	331	
11	1105	545	250	782	775	180	710	392	
12	1260	615	250	790	930	265	780	392	

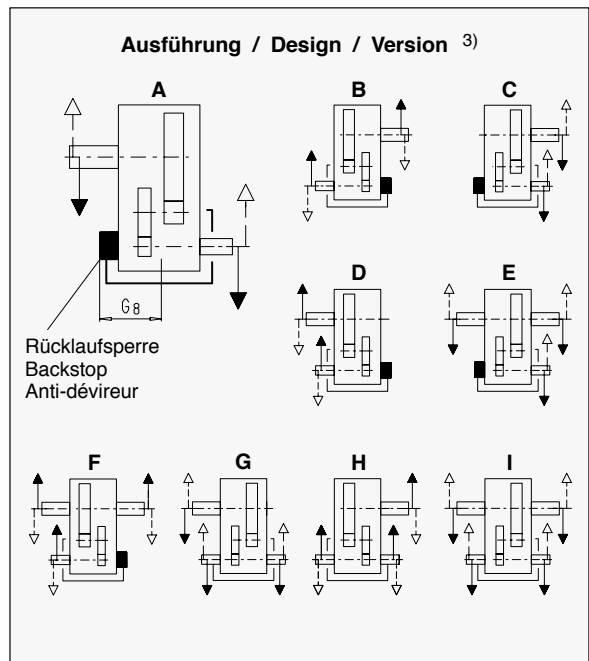

+) max. Abmessungen; Einzelheiten nach auftragsbezogener Dokumentation.

+) Max. dimensions; details acc. to order-related documentation.

+) Dimensions maximales; détails selon documentation relative à la commande.



# Zahnradgetriebe

Zweistufig  
Horizontal  
Bauart H2.H  
Größen 4 - 12

# Gear Units

Two Stage  
Horizontal  
Type H2.H  
Sizes 4 - 12

# Réducteurs à engrenages

à deux trains  
Horizontal  
Type H2.H  
Tailles 4 - 12

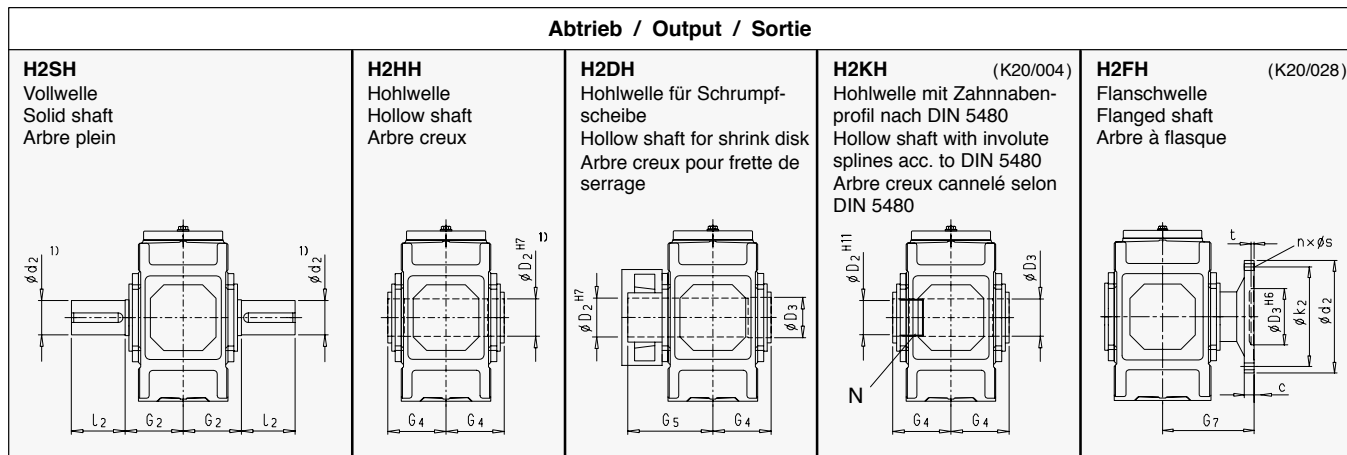

Größe Size Taille	H2SH			H2HH		H2DH				H2KH				H2FH										
	d <sub>2</sub>	l <sub>2</sub>	G <sub>2</sub>	D <sub>2</sub>	G <sub>4</sub>	D <sub>2</sub>	D <sub>3</sub>	G <sub>4</sub>	G <sub>5</sub>	N / DIN 5480				D <sub>2</sub>	D <sub>3</sub>	G <sub>4</sub>	c	d <sub>2</sub>	D <sub>3</sub>	k <sub>2</sub>	n x s	t	G <sub>7</sub>	
4	80	170	140	80	140	85	85	140	205	-				-	-	-	-	-	-	-	-	-	-	-
5	100	210	165	95	165	100	100	165	240	N 95x3x30x30x9H				89	100	165	25	300	150	260	16 x 22	10	255	
6	110	210	165	105	165	110	110	165	240	N 95x3x30x30x9H				89	110	165	25	320	160	280	18 x 22	10	255	
7	120	210	195	115	195	120	120	195	280	N 120x3x30x38x9H				114	120	195	30	370	180	320	16 x 26	10	300	
8	130	250	195	125	195	130	130	195	285	N 120x3x30x38x9H				114	130	195	30	390	190	340	18 x 26	10	300	
9	140	250	235	135	235	140	145	235	330	N 140x3x30x45x9H				134	145	235	38	430	220	380	20 x 26	12	350	
10	160	300	235	150	235	150	155	235	350	N 140x3x30x45x9H				134	155	235	38	470	240	420	22 x 26	12	350	
11	170	300	270	165	270	165	170	270	400	N 170x5x30x32x9H				160	170	270	42	510	260	450	18 x 33	12	400	
12	180	300	270	180	270	180	185	270	405	N 170x5x30x32x9H				160	185	270	42	540	280	480	22 x 33	12	400	

Größe Size Taille	Ölmenge / Oil quantity Quantité de huile (l) *)		Gewicht / Weight Poids (kg) **) **)		Kühlschlange / Cooling coil Serpentin de refroidissement		Abtrieb / Output / Sortie	Größe Size Taille			
	Wellen- dichtung Shaft seal Joint à lèvre	Labyrinth- dichtung Labyrinth seal Etanchéité à labyrinthe	H2SH H2HH H2DH H2KH	H2FH	Wasseranschluß für Kühl- schlange G1/2" Water connection for cool- ing coil G1/2" Adduction pour serpentin de refroidissement G1/2"	Kühlschlange geeignet für Süß-, See- und Brack- wasser / Cooling coil suitable for fresh, sea and brackish water / Serpentin de refroi- dissement adapté à l'eau douce, de mer et saumâtre		b <sub>10</sub>	e <sub>10</sub>	h <sub>10</sub>	l/(min x)
4	10	7	190	-							
5	15	11	300	335							
6	16	12	355	395							
7	27	21	505	555							
8	30	23	590	645							
9	42	33	830	915							
10	45	34	960	1050							
11	71	58	1335	1465							
12	76	60	1615	1755							

Abmessungen in mm

1) **Wellen:**

- m<sub>6</sub> <= Ø 100; n<sub>6</sub> > Ø 100
- Paßfedernut nach DIN 6885/1, Nabennutbreite nach ISO JS9
- Paßfeder nach DIN 6885/1 Form B
- Einzelheiten siehe Seiten 126 - 135

2) Vor dem Befestigen der Fußschrauben ist die Luftleithaube zu entfernen.

3) **Varianten:**

- Rücklaufsperrung nicht in Verbindung mit Ausführung G, H und I.

\*) Richtwerte; genaue Angaben nach auftragsbezogener Dokumentation. Wellenabdichtungen siehe Seiten 158 - 160

\*\*) ohne Ölfüllung

Dimensions in mm

1) **Shafts:**

- m<sub>6</sub> <= Ø 100; n<sub>6</sub> > Ø 100
- Keyway acc. to DIN 6885/1, Hub keyway width acc. to ISO JS9
- Parallel key acc. to DIN 6885/1 form B
- For details, see pages 126 - 135

2) Remove air guide cover before fitting the foundation bolts.

3) **Variants:**

- Backstop not possible with G, H and I designs.

\*) Approximate values; exact data acc. to order-related documentation. For shaft seals, see pages 158 - 160

\*\*) Without oil filling

Dimensions en mm

1) **Arbres:**

- m<sub>6</sub> <= Ø 100; n<sub>6</sub> > Ø 100
- Rainure de clavette selon DIN 6885/1, Tolérance dans le moyeu selon ISO JS9
- Clavette selon DIN 6885/1 forme B
- Détails voir pages 126 - 135

2) Pour la mise en place des vis / écrous, enlever le capot du ventilateur

3) **Variantes:**

- Impossibilité de monter un anti-dévireur avec les exécutions G, H et I.

\*) Valeurs approximatives; données exactes selon documentation relative à la commande. Etanchéités par labyrinthes voir pages 158 - 160

\*\*) sans huile



# Zahnradgetriebe

Zweistufig  
Horizontal  
Bauarten H2.H, H2.M  
Größen 13 - 22

# Gear Units

Two Stage  
Horizontal  
Types H2.H, H2.M  
Sizes 13 - 22

# Réducteurs à engrenages

à deux trains  
Horizontal  
Types H2.H, H2.M  
Tailles 13 - 22

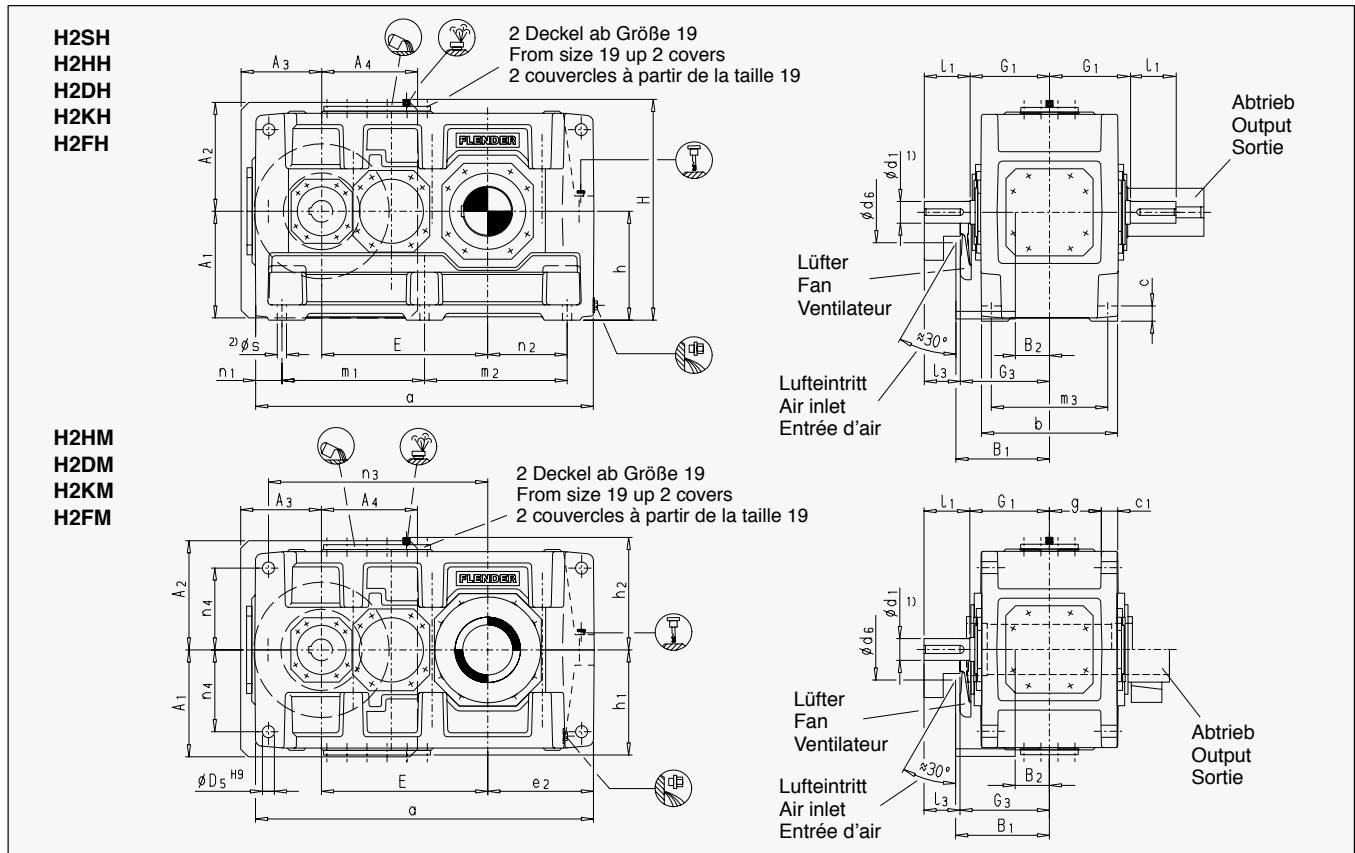

Größe Size Taille	Antrieb / Input / Entrée						Ausführung / Design Version G, H, I nur für / only for seulement pour i <sub>N</sub> =		Lüfter / Fan / Ventilateur								
	i <sub>N</sub> = 6.3 - 11.2			i <sub>N</sub> = 12.5 - 20					G <sub>1</sub>	G <sub>3</sub>	A <sub>1</sub>	A <sub>2</sub>	A <sub>3</sub>	A <sub>4</sub>	B <sub>1</sub>	B <sub>2</sub>	d <sub>6</sub>
	d <sub>1</sub>	l <sub>1</sub>	l <sub>3</sub>	d <sub>1</sub>	l <sub>1</sub>	l <sub>3</sub>											
13 + 14	100	205	170	85	170	135	330	365	6.3 - 16	8 - 20	430	460	330	365	385	135	250
15 + 16	120	210	165	100	210	165	365	410	6.3 - 16	7.1 - 18	490	500	370	440	430	155	280
17 + 18	125	245	200	110	210	165	420	465	6.3 - 16	7.1 - 18	540	565	435	505	485	140	280
19 + 20	150	245	200	120	210	165	475	520	Auf Anfrage / On request / Sur demande		600	600	500	450	540	190	310
21 + 22	170	290	240	140	250	200	495	545			680	680	500	610	565	200	450

Größe Size Taille	Zahnradgetriebe / Gear units / Réducteurs à engrenages											
	b	c	c <sub>1</sub>	D <sub>5</sub>	g	h <sub>-1</sub>	h <sub>1</sub>	h <sub>2</sub>	m <sub>3</sub>	n <sub>1</sub>	n <sub>4</sub>	s
13 + 14	550	60	61 ± 2	48	211.5	440	450	460	475	100	340	35
15 + 16	625	70	72 ± 2	55	238	500	490	500	535	120	375	42
17 + 18	690	80	81 ± 2	55	259	550	555	560	600	135	425	42
19 + 20	790	90	91 ± 2	65	299	620	615	620	690	155	475	48
21 + 22	830	100	100 ± 2	75	310	700	685	690	720	170	520	56

Größe Size Taille	Zahnradgetriebe / Gear units / Réducteurs à engrenages								
	a	e <sub>2</sub>	E	H	m <sub>1</sub>	m <sub>2</sub>	n <sub>2</sub>	n <sub>3</sub>	Rücklaufsperre Backstop / Anti-dévi- reurs (G <sub>8</sub> +)
13	1290	405	635	900	545	545	305	835	448
14	1430	475	705	900	545	685	375	905	448
15	1550	485	762	1000	655	655	365	1005	527
16	1640	530	808	1000	655	745	410	1050	527
17	1740	525	860	1110	735	735	390	1145	576
18	1860	585	920	1110	735	855	450	1205	576
19	2010	590	997	1240	850	850	435	1345	670
20	2130	650	1057	1240	850	970	495	1405	670
21	2140	655	1067	1390	900	900	485	1400	690
22	2250	710	1122	1390	900	1010	540	1455	690

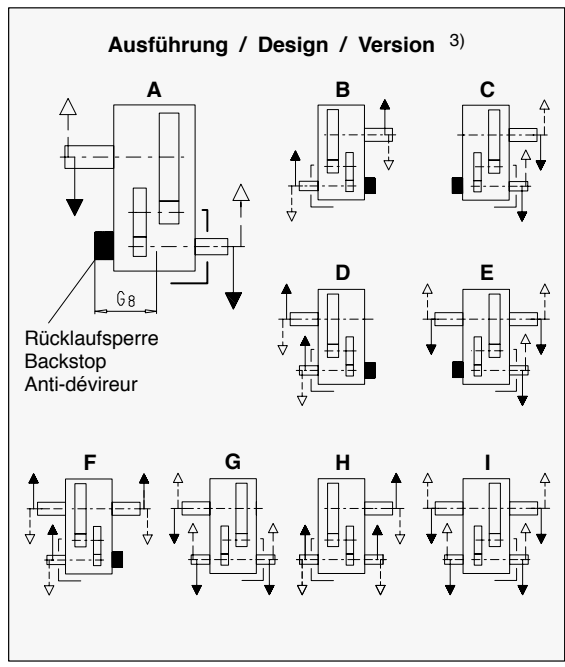

+) max. Abmessungen; Einzelheiten nach auftragsbezogener Dokumentation.

+) Max. dimensions; details acc. to order-related documentation.

+) Dimensions maximales; détails selon documentation relative à la commande.

# Zahnradgetriebe

Zweistufig  
Horizontal  
Bauarten H2.H, H2.M  
Größen 13 - 22

# Gear Units

Two Stage  
Horizontal  
Types H2.H, H2.M  
Sizes 13 - 22

# Réducteurs à engrenages

à deux trains  
Horizontal  
Types H2.H, H2.M  
Tailles 13 - 22

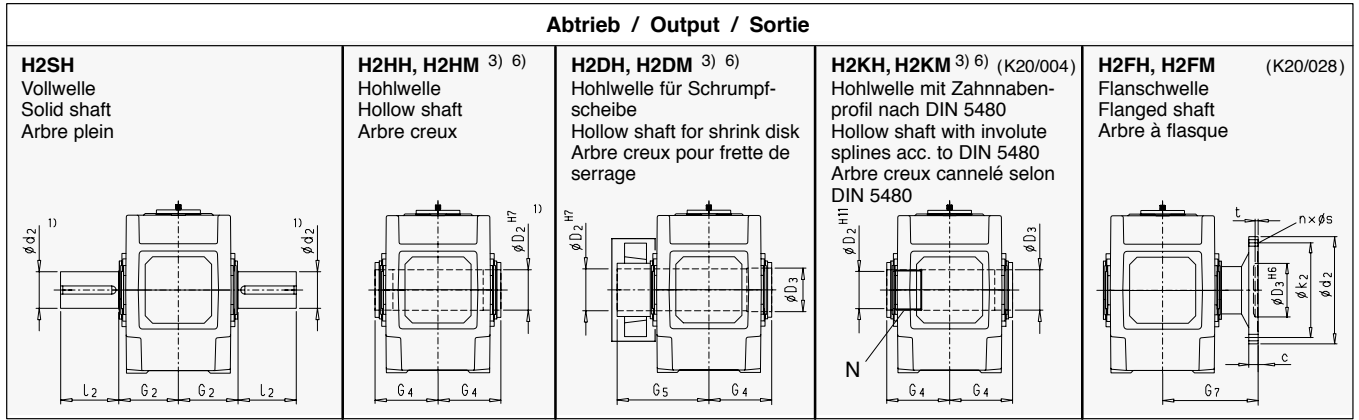

Größe Size Taille	H2SH			H2HH, H2HM		H2DH, H2DM				H2KH, H2KM				H2FH, H2FM						
	d <sub>2</sub>	l <sub>2</sub>	G <sub>2</sub>	D <sub>2</sub>	G <sub>4</sub>	D <sub>2</sub>	D <sub>3</sub>	G <sub>4</sub>	G <sub>5</sub>	N / DIN 5480	D <sub>2</sub>	D <sub>3</sub>	G <sub>4</sub>	c	d <sub>2</sub>	D <sub>3</sub>	k <sub>2</sub>	n x s	t	G <sub>7</sub>
13	200	350	335	190	335	190	195	335	480	N 190x5x30x36x9H	180	195	335	48	580	310	500	20 x 33	14	480
14	210	350	335	210	335	210	215	335	480	N 190x5x30x36x9H	180	215	335	48	620	310	540	24 x 33	14	480
15	230	410	380	230	380	230	235	380	550	N 220x5x30x42x9H	210	235	380	55	710	360	630	28 x 33	17	550
16	240	410	380	240	380	240	245	380	550	N 220x5x30x42x9H	210	245	380	55	740	360	660	30 x 33	17	550
17	250	410	415	250	415	250	260	415	600	N 250x5x30x48x9H	240	260	415	60	750	410	660	24 x 39	18	600
18	270	470	415	275	415	280	285	415	600	N 250x5x30x48x9H	240	285	415	60	800	410	710	26 x 39	18	600
19	290	470	465	-	-	285	295	465	670	Auf Anfrage On request Sur demande										
20	300	500	465	-	-	310	315	465	670		65	860	460	770	30 x 39	18	670			
21	320	500	490	-	-	330	335	490	715		65	930	460	830	32 x 39	18	670			
22	340	550	490	-	-	340	345	490	725		75	950	520	850	28 x 45	20	710			
											75	1040	520	940	28 x 45	20	710			

Größe Size Taille	Ölmenge / Oil quantity Quantité de huile (l) *)		Gewicht / Weight / Poids (kg) **) **)				
	H2.H	H2.M	H2SH H2HH H2DH H2KH	H2HM H2KM H2DM	H2FH	H2FM	
13	135	120	110	2000	1880	2160	2040
14	140	130	115	2570	2430	2740	2600
15	210	190	160	3430	3240	3670	3480
16	215	200	165	3655	3465	3910	3720
17	290	260	230	4650	4420	4950	4720
18	300	270	240	5125	4870	5475	5220
19	320	-	300	6600	6300	Auf Anfrage On request Sur demande	
20	340	-	320	7500	7200		
21	320	-	350	8900	8400		
22	340	-	370	9600	9200		

**Kühlschlange / Cooling coil  
Serpentin de refroidissement**

Größe Size Taille	b <sub>10</sub>	e <sub>10</sub>	e <sub>11</sub>	h <sub>10</sub>	h <sub>11</sub>	l/min x)
13	252	455	335	116	300	8
14	252	525	405	116	300	8
15	290	535	395	119	335	8
16	290	580	440	119	335	8
17	340	575	425	134	380	8
18	340	635	485	134	380	8
19	Auf Anfrage On request Sur demande					
20						
21						
22						

Wasseranschluss für Kühlschlange G1/2"  
Water connection for cooling coil G1/2"  
Adduction pour serpentin de refroidissement G1/2"

Kühlschlange geeignet für Süß-, See- und Brackwasser / Cooling coil suitable for fresh, sea and brackish water  
Serpentin de refroidissement adapté à l'eau douce, de mer et saumâtre

x) Erforderliche Kühlwassermenge, max. Kühlwasserdruck: 8 bar / Cooling water quantity required; max. cooling water pressure: 8 bar / Quantité d'eau de refroidissement nécessaire, pression maxi de l'eau de refroidissement: 8 bar

**Abmessungen in mm**

- Wellen:**
  - m<sub>6</sub> <= Ø 100; n<sub>6</sub> > Ø 100
  - Paßfedernut nach DIN 6885/1, Nabennutbreite nach ISO JS9
  - Paßfeder nach DIN 6885/1 Form B
  - Einzelheiten siehe Seiten 126 - 135
- Vor dem Befestigen der Fußschrauben ist die Luftleithaube zu entfernen.
- Varianten:**
  - Rücklaufsperrung nicht in Verbindung mit Ausführung G, H und I.
  - Aufsteckgetriebe (H2.M) nicht mit Labyrinthdichtung.
- Größen 13 und 15: nur i<sub>N</sub> = 6.3 - 18  
Größen 17 und 19: nur i<sub>N</sub> = 6.3 - 16
- \*) Richtwerte; genaue Angaben nach auftragsbezogener Dokumentation.  
Wellenabdichtungen siehe Seiten 158 - 160
- \*\*) ohne Ölfüllung

**Dimensions in mm**

- Shafts:**
  - m<sub>6</sub> <= Ø 100; n<sub>6</sub> > Ø 100
  - Keyway acc. to DIN 6885/1, Hub keyway width acc. to ISO JS9
  - Parallel key acc. to DIN 6885/1 form B
  - For details, see pages 126 - 135
- Remove air guide cover before fitting the foundation bolts.
- Variants:**
  - Backstop not possible with G, H and I designs.
  - Shaft-mounted gear unit (H2.M) not with labyrinth seal.
- Sizes 13 and 15: only i<sub>N</sub> = 6.3 - 18  
Sizes 17 and 19: only i<sub>N</sub> = 6.3 - 16
- \*) Approximate values; exact data acc. to order-related documentation.  
For shaft seals, see pages 158 - 160
- \*\*) Without oil filling

**Dimensions en mm**

- Arbres:**
  - m<sub>6</sub> <= Ø 100; n<sub>6</sub> > Ø 100
  - Rainure de clavette selon DIN 6885/1, Tolérance dans le moyeu selon ISO JS9
  - Clavette selon DIN 6885/1 forme B
  - Détails voir pages 126 - 135
- Pour la mise en place des vis / écrous, enlever le capot du ventilateur
- Variantes:**
  - Impossibilité de monter un anti-dévireur avec les exécutions G, H et I.
  - Réducteur à arbre creux (H2.M) non livrable avec joint labyrinthe.
- Tailles 13 et 15: uniquement i<sub>N</sub> = 6.3 - 18  
Tailles 17 et 19: uniquement i<sub>N</sub> = 6.3 - 16
- \*) Valeurs approximatives; données exactes selon documentation relative à la commande.  
Etanchéités par labyrinthes voir pages 158 - 160
- \*\*) sans huile

# Zahnradgetriebe

Zweistufig  
Horizontal  
Bauarten H2.H, H2DM  
Größen 23 - 26

# Gear Units

Two Stage  
Horizontal  
Types H2.H, H2DM  
Sizes 23 - 26

# Réducteurs à engrenages

à deux trains  
Horizontal  
Types H2.H, H2DM  
Tailles 23 - 26

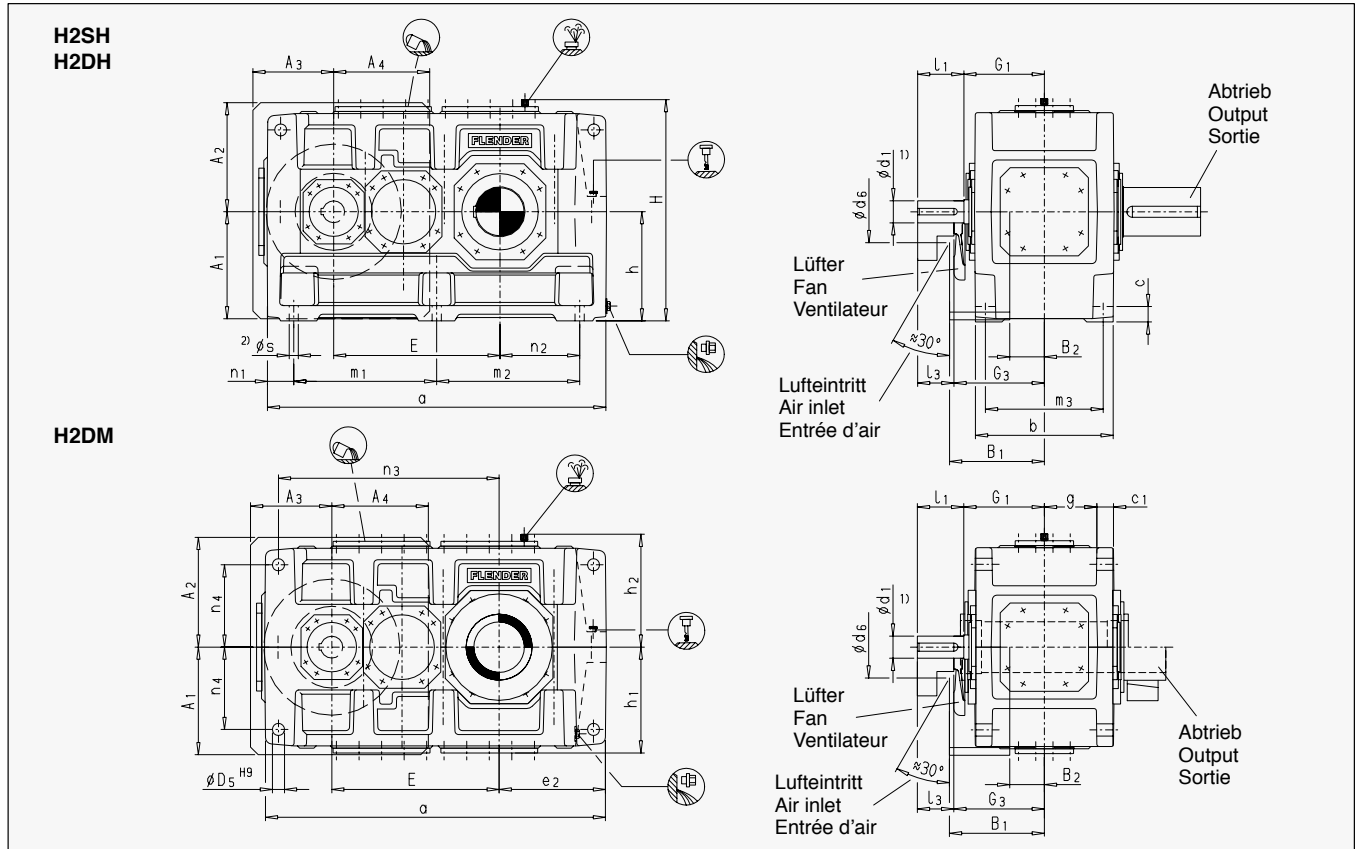

Größe Size Taille	Antrieb / Input / Entrée						3) Ausführung / Design Version G, H, I nur für / only for seulement pour $i_N =$		Lüfter / Fan / Ventilateur								
	$i_N = 6.3 - 11.2$			$i_N = 12.5 - 20$					$G_1$	$G_3$	$A_1$	$A_2$	$A_3$	$A_4$	$B_1$	$B_2$	$d_6$
	$d_1$	$l_1$	$l_3$	$d_1$	$l_1$	$l_3$											
23 + 24	190	330	280	150	250	200	560	610	770	770	550	550	630	220	450		
25 + 26	200	340	290	170	300	250	600	650	845	865	550	550	670	240	450		

Größe Size Taille	Zahnradgetriebe / Gear units / Réducteurs à engrenages											
	b	c	$c_1$	$D_5$	g	$h_{-1}$	$h_1$	$h_2$	$m_3$	$n_1$	$n_4$	s
23 + 24	930	115	$120 \pm 2$	80	342	780	770	770	810	180	580	56
25 + 26	1045	130	$120 \pm 2$	90	400	860	860	860	910	200	660	66

Größe Size Taille	Zahnradgetriebe / Gear units / Réducteurs à engrenages								Rücklauf- sperre Backstop Antidévireur $G_8$
	a	$e_2$	E	H	$m_1$	$m_2$	$n_2$	$n_3$	
23	2380	730	1185	1550	1010	1010	550	1560	Maße auf Anfrage Dimensions on request Dimensions sur demande
24	2510	795	1250	1550	1010	1140	615	1625	
25	2580	790	1325	1720	1090	1090	590	1685	
26	2760	880	1415	1720	1090	1270	680	1775	

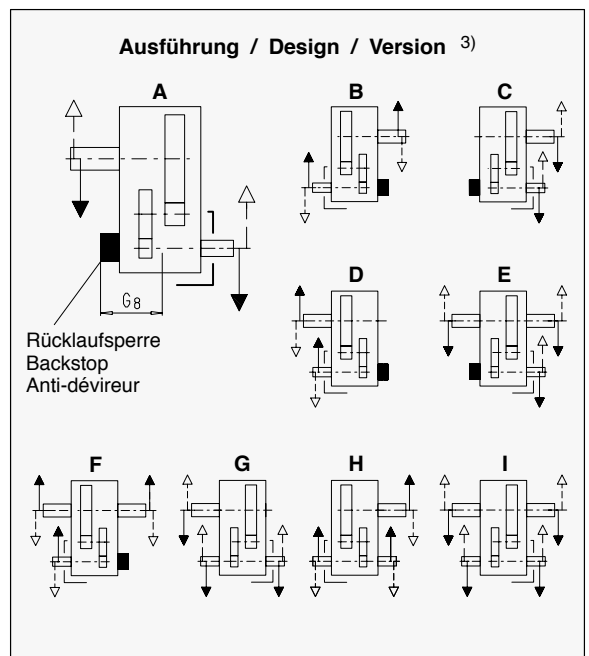

## Zahnradgetriebe

Zweistufig  
Horizontal  
Bauarten H2.H, H2DM  
Größen 23 - 26

## Gear Units

Two Stage  
Horizontal  
Types H2.H, H2DM  
Sizes 23 - 26

## Réducteurs à engrenages

à deux trains  
Horizontal  
Types H2.H, H2DM  
Tailles 23 - 26

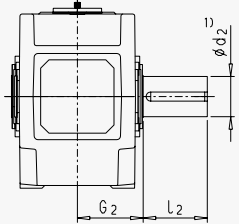
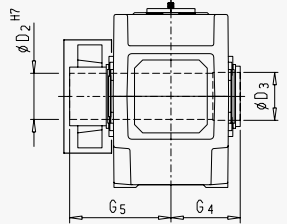
Abtrieb / Output / Sortie		
<b>H2SH</b> Vollwelle Solid shaft Arbre plein 	<b>H2DH, H2DM</b> <sup>3)</sup> Hohlwelle für Schrumpfscheibe Hollow shaft for shrink disk Arbre creux pour frette de serrage 	

Größe Size Taille	H2SH			H2DH, H2DM			
	d <sub>2</sub>	l <sub>2</sub>	G <sub>2</sub>	D <sub>2</sub>	D <sub>3</sub>	G <sub>4</sub>	G <sub>5</sub>
23	360	590	540	360	365	540	785
24	380	590	540	380	385	540	805
25	400	650	605	400	405	605	875
26	420	650	605	430	435	605	900

Größe Size Taille	Ölmenge Oil quantity Quantité de huile (l) <sup>*)</sup>		Gewicht Weight / Poids (kg) <sup>*) **)</sup>		Kühlschlange / Cooling coil Serpentin de refroidissement							
	H2SH	H2DM	H2SH H2DH	H2DM	H2.H	H2DM	b <sub>10</sub>	e <sub>10</sub>	e <sub>11</sub>	h <sub>10</sub>	h <sub>11</sub>	l/min x)
23	430	470	11600	11000								Auf Anfrage On request Sur demande
24	450	500	13000	12300								
25	600	660	15500	14700								
26	640	700	17200	16200								

Abtrieb / Output / Sortie

Abtrieb / Output / Sortie

Wasseranschluß für Kühlschlange G1/2"  
Water connection for cooling coil G1/2"  
Adduction pour serpentin de refroidissement G1/2"

Kühlschlange geeignet für Süß-, See- und Brackwasser  
Cooling coil suitable for fresh, sea and brackish water  
Serpentin de refroidissement adapté à l'eau douce, de mer et saumâtre

x) Erforderliche Kühlwassermenge, max. Kühlwasserdruck: 8 bar  
Cooling water quantity required; max. cooling water pressure: 8 bar  
Quantité d'eau de refroidissement nécessaire, pression maxi de l'eau de refroidissement: 8 bar

Abmessungen in mm

### 1) Wellen:

- n<sub>6</sub> > Ø 100
- Paßfedernut nach DIN 6885/1, Nabennutbreite nach ISO JS9
- Paßfeder nach DIN 6885/1 Form B
- Einzelheiten siehe Seiten 126 - 135

2) Vor dem Befestigen der Fußschrauben ist die Luftleithaube zu entfernen.

### 3) Varianten:

- Rücklaufperre nicht in Verbindung mit Ausführung G, H und I.
- Aufsteckgetriebe (H2DM) nicht mit Labyrinthdichtung.

\*) Richtwerte; genaue Angaben nach auftragsbezogener Dokumentation.

\*\*\*) ohne Ölfüllung

Dimensions in mm

### 1) Shafts:

- n<sub>6</sub> > Ø 100
- Keyway acc. to DIN 6885/1, Hub keyway width acc. to ISO JS9
- Parallel key acc. to DIN 6885/1 form B
- For details, see page 126 - 135

2) Remove air guide cover before fitting the foundation bolts.

### 3) Variants:

- Backstop not possible with G, H and I designs.
- Shaft-mounted gear unit (H2DM) not with labyrinth seal.

\*) Approximate values; exact data acc. to order-related documentation.

\*\*\*) Without oil filling

Dimensions en mm

### 1) Arbres:

- n<sub>6</sub> > Ø 100
- Rainure de clavette selon DIN 6885/1, Tolérance dans le moyeu selon ISO JS9
- Clavette selon DIN 6885/1 forme B
- Détails voir pages 126 - 135

2) Pour la mise en place des vis / écrous, enlever le capot du ventilateur

### 3) Variantes:

- Impossibilité de monter un anti-dévireur avec les exécutions G, H et I.
- Réducteur à arbre creux (H2DM) non livrable avec joint labyrinthe.

\*) Valeurs approximatives; données exactes selon documentation relative à la commande.

\*\*\*) sans huile

# Zahnradgetriebe

Dreistufig  
Horizontal  
Bauart H3.H  
Größen 5 - 12

# Gear Units

Three Stage  
Horizontal  
Type H3.H  
Sizes 5 - 12

# Réducteurs à engrenages

à trois trains  
Horizontal  
Type H3.H  
Tailles 5 - 12

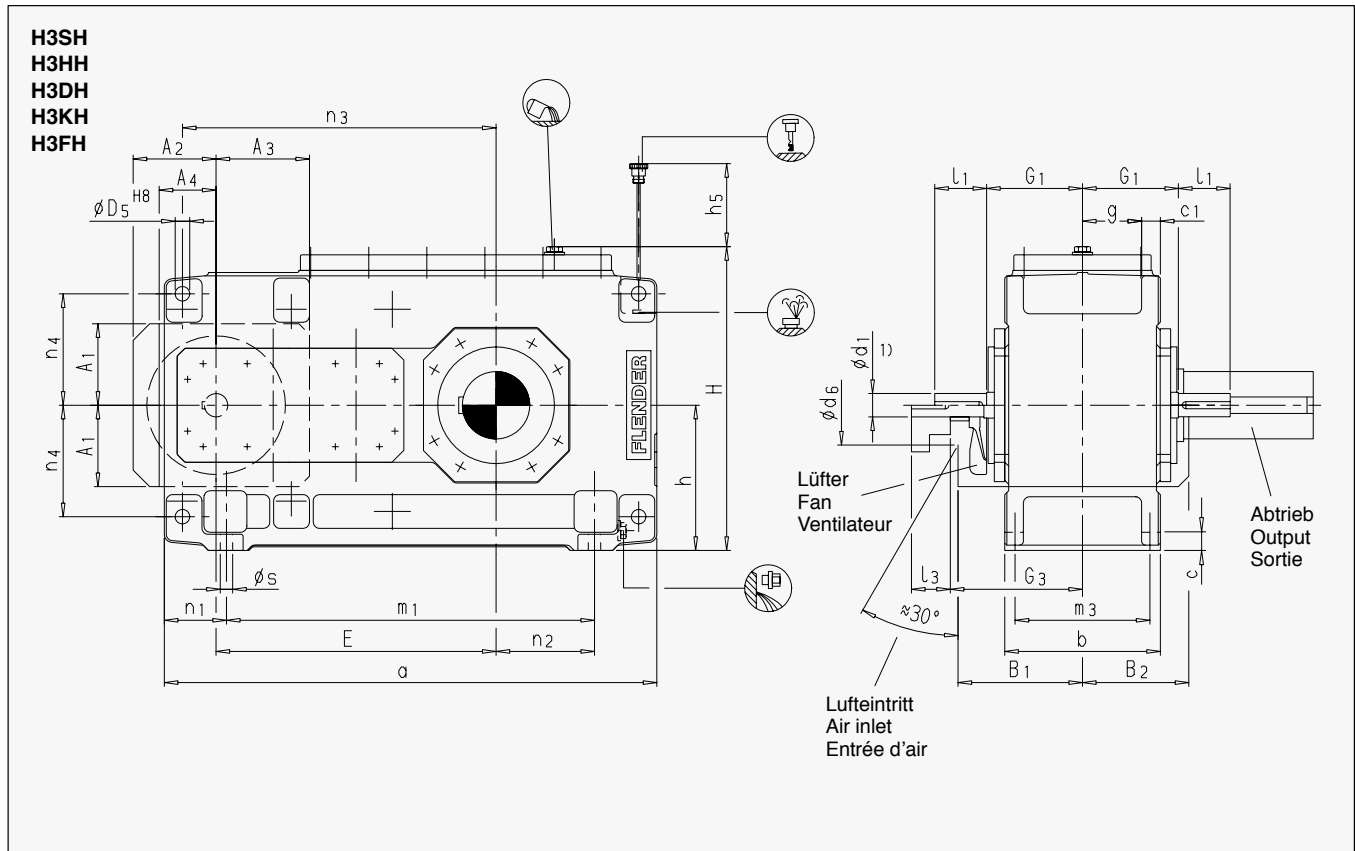

Größe Size Taille	Antrieb / Input / Entrée									Ausführung / Design Version G, H, I nur für / only for seulement pour $i_N =$		Lüfter / Fan / Ventilateur								
	$i_N = 25 - 45$			$i_N = 50 - 63$			$i_N = 71 - 90$					$G_1$	$G_3$	$A_1$	$A_2$	$A_3$	$A_4$	$B_1$	$B_2$	$d_6$
	$i_N = 31.5 - 56$	$i_N = 63 - 80$	$i_N = 90 - 112$	$d_1$	$l_1$	$l_3$	$d_1$	$l_1$	$l_3$											
5 + 6	40	70	70	30	50	50	24	40	40	160	220	25 - 90	31.5 - 112	137	135	140	140	215	175	60
7 + 8	45	80	80	35	60	60	28	50	50	185	250	25 - 90	31.5 - 112	157	160	180	180	245	205	75
9 + 10	60	125	105	45	100	80	32	80	60	230	300	25 - 90	31.5 - 112	182	190	205	205	295	240	90
11 + 12	70	120	120	50	80	80	42	70	70	255	330	25 - 90	31.5 - 112	218	220	255	255	325	280	100

Größe Size Taille	Zahnradgetriebe / Gear units / Réducteurs à engrenages									
	b	c	$c_1$	$D_5$	g	$h_{-1}$	$m_3$	$n_1$	$n_4$	s
5 + 6	255	28	$30 \pm 1$	24	97.5	230	220	105	180	19
7 + 8	300	35	$36 \pm 1$	28	114	280	260	120	215	24
9 + 10	370	40	$45 \pm 1.5$	36	140	320	320	145	245	28
11 + 12	430	50	$54 \pm 1.5$	40	161	380	370	165	300	35

Größe Size Taille	Zahnradgetriebe / Gear units / Réducteurs à engrenages							Rücklaufsperre Backstop / Anti- dévireur $G_8^{+)}$
	a	E	$h_5$	H	$m_1$	$n_2$	$n_3$	
5	690	405	130	482	480	100	455	234
6	770	440	130	482	560	145	490	234
7	845	495	170	572	605	130	560	287
8	950	540	160	582	710	190	605	287
9	1000	580	185	662	710	155	660	317
10	1100	630	185	662	810	205	710	317
11	1200	705	180	782	870	180	805	369
12	1355	775	170	790	1025	265	875	369

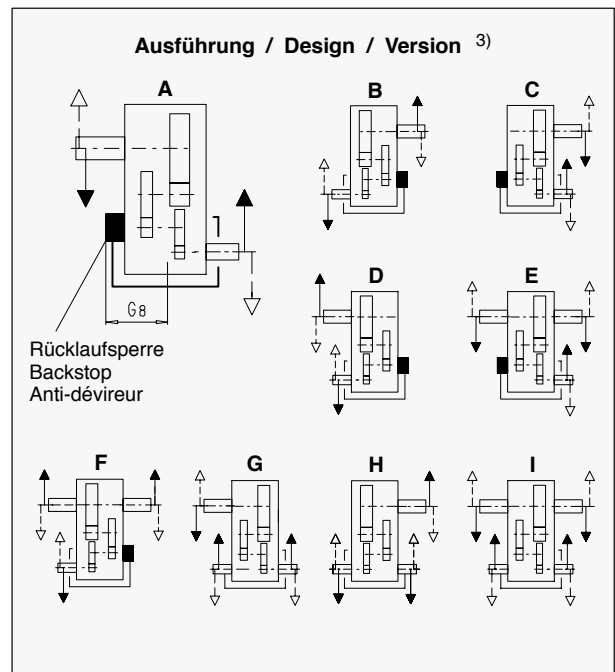

+) max. Abmessungen; Einzelheiten nach auftragsbezogener Dokumentation.

+) Max. dimensions; details acc. to order-related documentation.

+) Dimensions maximales; détails selon documentation relative à la commande.

# Zahnradgetriebe

Dreistufig  
Horizontal  
Bauart H3.H  
Größen 5 - 12

# Gear Units

Three Stage  
Horizontal  
Type H3.H  
Sizes 5 - 12

# Réducteurs à engrenages

à trois trains  
Horizontal  
Type H3.H  
Tailles 5 - 12

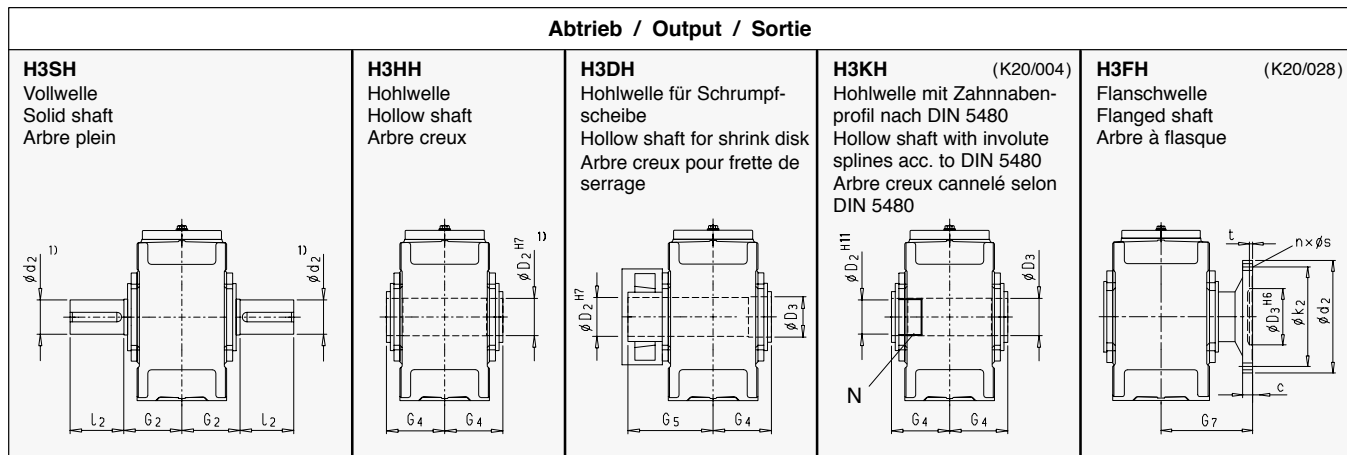

Größe Size Taille	H3SH			H3HH		H3DH				H3KH				H3FH							
	d <sub>2</sub>	l <sub>2</sub>	G <sub>2</sub>	D <sub>2</sub>	G <sub>4</sub>	D <sub>2</sub>	D <sub>3</sub>	G <sub>4</sub>	G <sub>5</sub>	N / DIN 5480		D <sub>2</sub>	D <sub>3</sub>	G <sub>4</sub>	c	d <sub>2</sub>	D <sub>3</sub>	k <sub>2</sub>	n x s	t	G <sub>7</sub>
5	100	210	165	95	165	100	100	165	240	N 95x3x30x30x9H		89	100	165	25	300	150	260	16 x 22	10	255
6	110	210	165	105	165	110	110	165	240	N 95x3x30x30x9H		89	110	165	25	320	160	280	18 x 22	10	255
7	120	210	195	115	195	120	120	195	280	N 120x3x30x38x9H		114	120	195	30	370	180	320	16 x 26	10	300
8	130	250	195	125	195	130	130	195	285	N 120x3x30x38x9H		114	130	195	30	390	190	340	18 x 26	10	300
9	140	250	235	135	235	140	145	235	330	N 140x3x30x45x9H		134	145	235	38	430	220	380	20 x 26	12	350
10	160	300	235	150	235	150	155	235	350	N 140x3x30x45x9H		134	155	235	38	470	240	420	22 x 26	12	350
11	170	300	270	165	270	165	170	270	400	N 170x5x30x32x9H		160	170	270	42	510	260	450	18 x 33	12	400
12	180	300	270	180	270	180	185	270	405	N 170x5x30x32x9H		160	185	270	42	540	280	480	22 x 33	12	400

Größe Size Taille	Ölmenge Oil quantity Quantité de huile (l) *)	Gewicht / Weight Poids (kg) **)		H3SH H3HH H3DH H3KH	H3FH
5	16	320	355		
6	18	365	405		
7	29	540	590		
8	32	625	675		
9	48	875	960		
10	49	1020	1110		
11	85	1400	1530		
12	90	1675	1815		

**Kühlschlange / Cooling coil  
Serpentin de refroidissement**

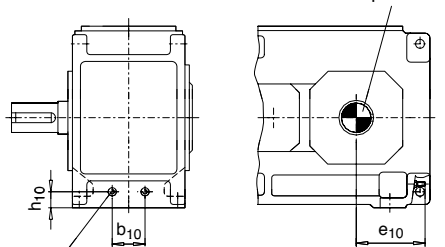

Abtrieb / Output / Sortie

Wasseranschluß für Kühlschlange G1/2"  
Water connection for cooling coil G1/2"  
Adduction pour serpentin de refroidissement G1/2"

Größe Size Taille	b <sub>10</sub>	e <sub>10</sub>	h <sub>10</sub>	l/(min x)
5	70	175	60	4
6	70	220	69	4
7	80	210	83	4
8	80	270	83	4
9	150	245	107	4
10	90	295	95	4
11	200	275	115	8
12	200	360	115	8

Kühlschlange geeignet für Süß-, See- und Brackwasser  
Cooling coil suitable for fresh, sea and brackish water  
Serpentin de refroidissement adapté à l'eau douce, de mer et saumâtre

x) Erforderliche Kühlwassermenge, max. Kühlwasserdruck: 8 bar  
Cooling water quantity required; max. cooling water pressure: 8 bar  
Quantité d'eau de refroidissement nécessaire, pression maxi de l'eau de refroidissement: 8 bar

Abmessungen in mm

**1) Wellen:**

- k<sub>6</sub> = Ø 24; Ø 28 ≥ m<sub>6</sub> ≤ Ø 100; n<sub>6</sub> > Ø 100
- Paßfedernut nach DIN 6885/1, Nabennutbreite nach ISO JS9
- Paßfeder nach DIN 6885/1 Form B
- Einzelheiten siehe Seiten 126 - 135

**3) Varianten:**

- Rücklauf Sperre nicht in Verbindung mit Ausführung G, H und I.

\*) Richtwerte; genaue Angaben nach auftragsbezogener Dokumentation.

\*\*) ohne Ölfüllung

Dimensions in mm

**1) Shafts:**

- k<sub>6</sub> = Ø 24; Ø 28 ≥ m<sub>6</sub> ≤ Ø 100; n<sub>6</sub> > Ø 100
- Keyway acc. to DIN 6885/1, Hub keyway width acc. to ISO JS9
- Parallel key acc. to DIN 6885/1 form B
- For details, see pages 126 - 135

**3) Variants:**

- Backstop not possible with G, H and I designs.

\*) Approximate values; exact data acc. to order-related documentation.

\*\*) Without oil filling

Dimensions en mm

**1) Arbres:**

- k<sub>6</sub> = Ø 24; Ø 28 ≥ m<sub>6</sub> ≤ Ø 100; n<sub>6</sub> > Ø 100
- Rainure de clavette selon DIN 6885/1, Tolérance dans le moyeu selon ISO JS9
- Clavette selon DIN 6885/1 forme B
- Détails voir pages 126 - 135

**3) Variantes:**

- Impossibilité de monter un anti-dévireur avec les exécutions G, H et I.

\*) Valeurs approximatives; données exactes selon documentation relative à la commande.

\*\*) sans huile



# Zahnradgetriebe

Dreistufig  
Horizontal  
Bauarten H3.H, H3.M  
Größen 13 - 22

# Gear Units

Three Stage  
Horizontal  
Types H3.H, H3.M  
Sizes 13 - 22

# Réducteurs à engrenages

à trois trains  
Horizontal  
Types H3.H, H3.M  
Tailles 13 - 22

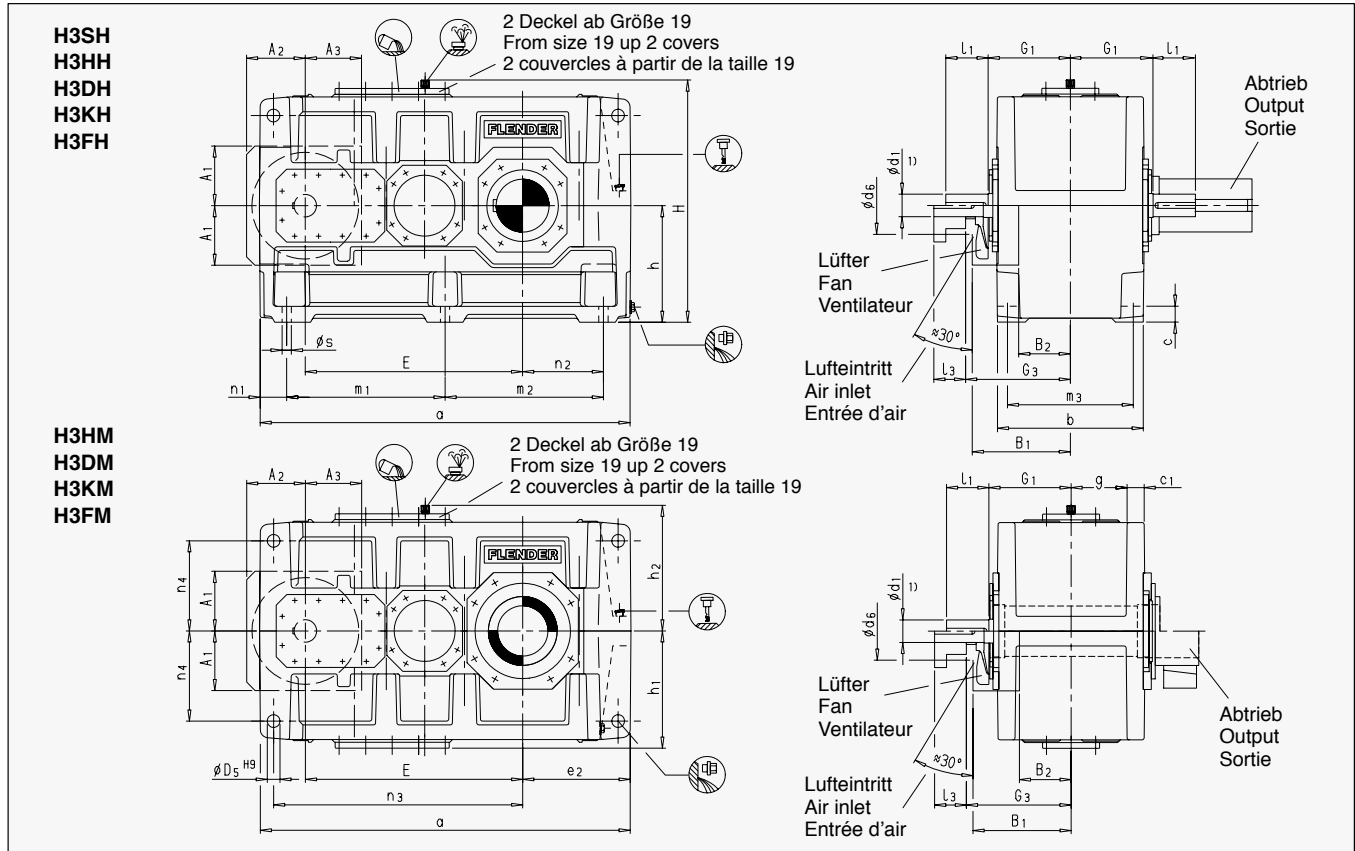

Größe Size Taille	Antrieb / Input / Entrée									Ausführung / Design Version G, H, I nur für / only for seulement pour $i_N =$		Lüfter / Fan / Ventilateur							
	$i_N = 22.4 - 45$			$i_N = 50 - 63$			$i_N = 71 - 90$					G <sub>1</sub>	G <sub>3</sub>	A <sub>1</sub>	A <sub>2</sub>	A <sub>3</sub>	B <sub>1</sub>	B <sub>2</sub>	d <sub>6</sub>
	d <sub>1</sub>	l <sub>1</sub>	l <sub>3</sub>	d <sub>1</sub>	l <sub>1</sub>	l <sub>3</sub>	d <sub>1</sub>	l <sub>1</sub>	l <sub>3</sub>										
13 + 14	85	160	130	60	135	105	50	110	80	310	385	22.4 - 90	28 - 112	225	225	212	380	195	120
15 + 16	100	200	165	75	140	105	60	140	105	350	420	22.4 - 90	25 - 100	270	265	252	415	205	150
17 + 18	100	200	165	75	140	105	60	140	105	380	450	22.4 - 90	25 - 100	270	265	252	455	235	150
19 + 20	110	200	-	90	165	-	75	140	-	430	-	Auf Anfrage / On request / Sur demande							
21 + 22	130	240	-	110	205	-	90	170	-	470	-								

Größe Size Taille	Zahnradgetriebe / Gear units / Réducteurs à engrenages											
	b	c	c <sub>1</sub>	D <sub>5</sub>	g	h <sub>-1</sub>	h <sub>1</sub>	h <sub>2</sub>	m <sub>3</sub>	n <sub>1</sub>	n <sub>4</sub>	s
13 + 14	550	60	61 ± 2	48	211.5	440	450	460	475	100	340	35
15 + 16	625	70	72 ± 2	55	238	500	490	500	535	120	375	42
17 + 18	690	80	81 ± 2	55	259	550	555	560	600	135	425	42
19 + 20	790	90	91 ± 2	65	299	620	615	620	690	155	475	48
21 + 22	830	100	100 ± 2	75	310	700	685	690	720	170	520	56

Größe Size Taille	Zahnradgetriebe / Gear units / Réducteurs à engrenages								
	a	e <sub>2</sub>	E	H	m <sub>1</sub>	m <sub>2</sub>	n <sub>2</sub>	n <sub>3</sub>	Rücklaufsperre Backstop / Anti- dévireur G <sub>8</sub> <sup>+) )</sup>
13	1395	405	820	900	597.5	597.5	305	940	457
14	1535	475	890	900	597.5	737.5	375	1010	457
15	1680	485	987	1000	720	720	365	1135	522
16	1770	530	1033	1000	720	810	410	1180	522
17	1770	525	1035	1110	750	750	390	1175	534
18	1890	585	1095	1110	750	870	450	1235	534
19	2030	590	1190	1240	860	860	435	1365	614
20	2150	650	1250	1240	860	980	495	1425	614
21	2340	655	1387	1390	1000	1000	485	1600	635
22	2450	710	1442	1390	1000	1110	540	1655	635

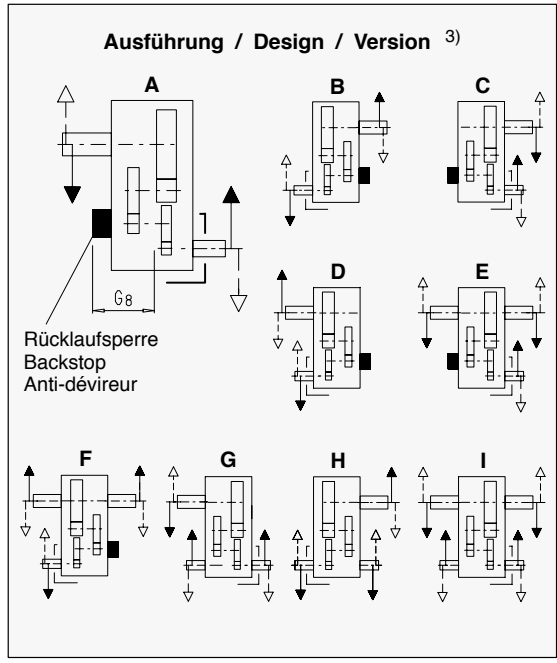

+) max. Abmessungen; Einzelheiten nach auftragsbezogener Dokumentation.

+) Max. dimensions; details acc. to order-related documentation.

+) Dimensions maximales; détails selon documentation relative à la commande.



# Zahnradgetriebe

Dreistufig  
Horizontal  
Bauarten H3.H, H3.M  
Größen 13 - 22

# Gear Units

Three Stage  
Horizontal  
Types H3.H, H3.M  
Sizes 13 - 22

# Réducteurs à engrenages

à trois trains  
Horizontal  
Types H3.H, H3.M  
Tailles 13 - 22

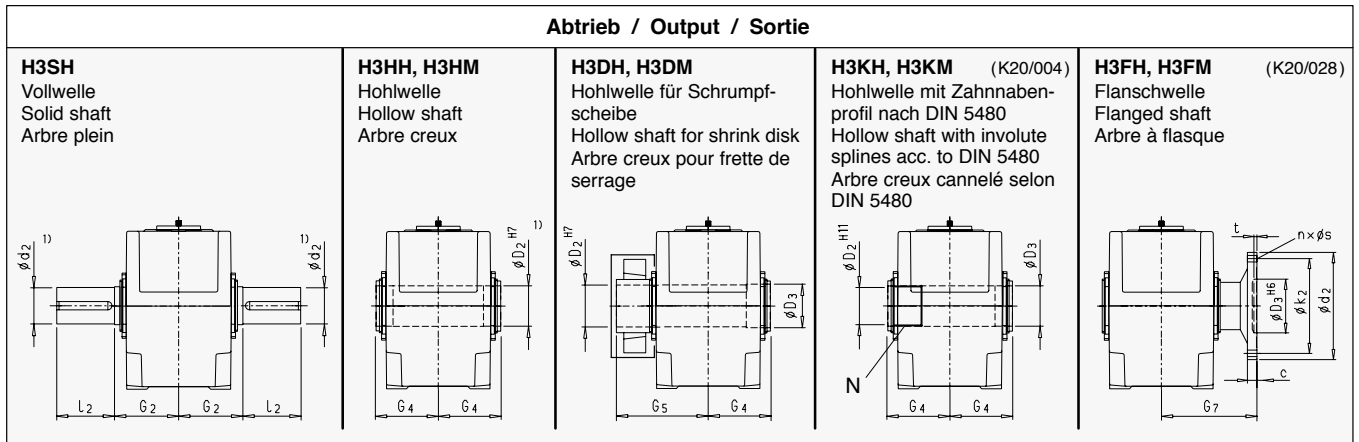

Größe Size Taille	H3SH			H3HH, H3HM		H3DH, H3DM				H3KH, H3KM				H3FH, H3FM								
	d <sub>2</sub>	l <sub>2</sub>	G <sub>2</sub>	D <sub>2</sub>	G <sub>4</sub>	D <sub>2</sub>	D <sub>3</sub>	G <sub>4</sub>	G <sub>5</sub>	N / DIN 5480			D <sub>2</sub>	D <sub>3</sub>	G <sub>4</sub>	c	d <sub>2</sub>	D <sub>3</sub>	k <sub>2</sub>	n x s	t	G <sub>7</sub>
13	200	350	335	190	335	190	195	335	480	N 190x5x30x36x9H			180	195	335	48	580	310	500	20 x 33	14	480
14	210	350	335	210	335	210	215	335	480	N 190x5x30x36x9H			180	215	335	48	620	310	540	24 x 33	14	480
15	230	410	380	230	380	230	235	380	550	N 220x5x30x42x9H			210	235	380	55	710	360	630	28 x 33	17	550
16	240	410	380	240	380	240	245	380	550	N 220x5x30x42x9H			210	245	380	55	740	360	660	30 x 33	17	550
17	250	410	415	250	415	250	260	415	600	N 250x5x30x48x9H			240	260	415	60	750	410	660	24 x 39	18	600
18	270	470	415	275	415	280	285	415	600	N 250x5x30x48x9H			240	285	415	60	800	410	710	26 x 39	18	600
19	290	470	465	-	-	285	295	465	670	Auf Anfrage On request Sur demande			65	860	460	770	30 x 39	18	670			
20	300	500	465	-	-	310	315	465	670				65	930	460	830	32 x 39	18	670			
21	320	500	490	-	-	330	335	490	715				75	950	520	850	28 x 45	20	710			
22	340	550	490	-	-	340	345	490	725				75	1040	520	940	28 x 45	20	710			

Größe Size Taille	Ölmenge / Oil quantity / Quantité de huile (l) *)		Gewicht / Weight / Poids (kg) *) **)			
	H3.H	H3.M	H3SH H3HH H3DH H3KH	H3HM H3KM H3DM	H3FH	H3FM
13	160	125	2295	2155	2455	2305
14	165	130	2625	2490	2795	2660
15	235	190	3475	3260	3715	3500
16	245	195	3875	3625	4130	3880
17	305	240	4560	4250	4860	4550
18	315	250	5030	4740	5380	5090
19	420	390	6700	6200	Auf Anfrage On request Sur demande	
20	450	415	8100	7600		
21	470	515	9100	8500		
22	490	540	9800	9300		

**Kühlschlange / Cooling coil  
Serpentin de refroidissement**

Größe Size Taille	b <sub>10</sub>	e <sub>10</sub>	e <sub>11</sub>	h <sub>10</sub>	h <sub>11</sub>	l/(min x)
13	252	460	335	116	300	8
14	252	530	405	116	300	8
15	290	540	395	119	335	8
16	290	585	440	119	335	8
17	300	580	425	134	380	8
18	300	640	485	134	380	8
19	Auf Anfrage On request Sur demande					
20						
21						
22						

Wasseranschluß für Kühlschlange G1/2"  
Water connection for cooling coil G1/2"  
Adduction pour serpentin de refroidissement G1/2"

x) Erforderliche Kühlwassermenge, max. Kühlwasserdruck: 8 bar / Cooling water quantity required; max. cooling water pressure: 8 bar / Quantité d'eau de refroidissement nécessaire, pression maxi de l'eau de refroidissement: 8 bar

Kühlschlange geeignet für Süß-, See- und Brackwasser / Cooling coil suitable for fresh, sea and brackish water / Serpentin de refroidissement adapté à l'eau douce, de mer et saumâtre

**Abmessungen in mm**

- Wellen:**
    - m<sub>6</sub> <= Ø 100; n<sub>6</sub> > Ø 100
    - Paßfedernut nach DIN 6885/1, Nabennutbreite nach ISO JS9
    - Paßfeder nach DIN 6885/1 Form B
    - Einzelheiten siehe Seiten 126 - 135
  - Varianten:**
    - Rücklaufsperre nicht in Verbindung mit Ausführung G, H und I.
- \*) Richtwerte; genaue Angaben nach auftragsbezogener Dokumentation.  
\*\*) ohne Ölfüllung

**Dimensions in mm**

- Shafts:**
    - m<sub>6</sub> <= Ø 100; n<sub>6</sub> > Ø 100
    - Keyway acc. to DIN 6885/1, Hub keyway width acc. to ISO JS9
    - Parallel key acc. to DIN 6885/1 form B
    - For details, see pages 126 - 135
  - Variants:**
    - Backstop not possible with G, H and I designs.
- \*) Approximate values; exact data acc. to order-related documentation.  
\*\*) Without oil filling

**Dimensions en mm**

- Arbres:**
    - m<sub>6</sub> <= Ø 100; n<sub>6</sub> > Ø 100
    - Rainure de clavette selon DIN 6885/1, Tolérance dans le moyeu selon ISO JS9
    - Clavette selon DIN 6885/1 forme B
    - Détails voir pages 126 - 135
  - Variantes:**
    - Impossibilité de monter un anti-dévireur avec les exécutions G, H et I.
- \*) Valeurs approximatives; données exactes selon documentation relative à la commande.  
\*\*) sans huile



# Zahnradgetriebe

Dreistufig  
Horizontal  
Bauarten H3.H, H3DM  
Größen 23 - 26

# Gear Units

Three Stage  
Horizontal  
Types H3.H, H3DM  
Sizes 23 - 26

# Réducteurs à engrenages

à trois trains  
Horizontal  
Types H3.H, H3DM  
Tailles 23 - 26

H3SH  
H3DH

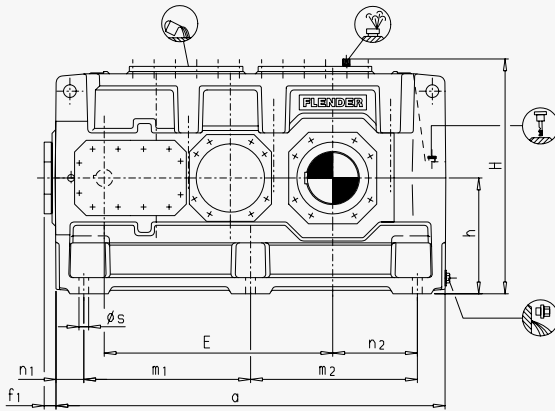

H3DM

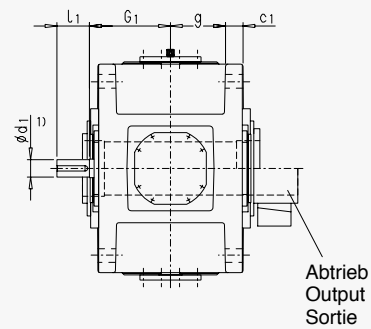
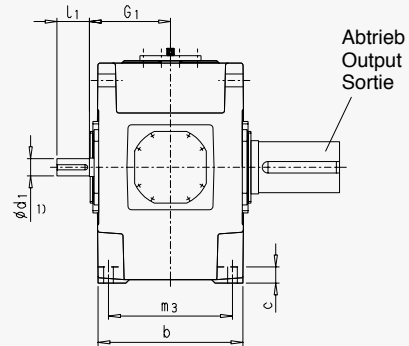
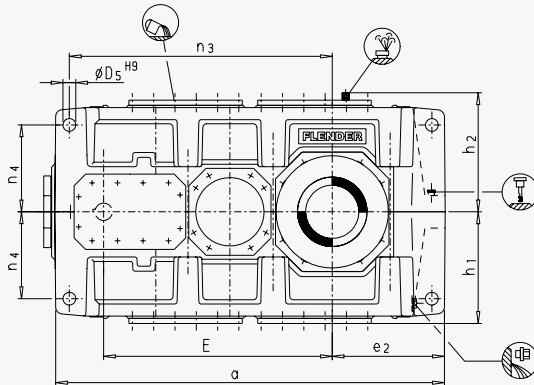

4

Größe Size Taille	Antrieb / Input / Entrée						G <sub>1</sub>	3) Ausführung / Design Version <b>G, H, I</b> nur für / only for seulement pour i <sub>N</sub> =
	i <sub>N</sub> = 22.4 - 45		i <sub>N</sub> = 50 - 63		i <sub>N</sub> = 71 - 90			
	d <sub>1</sub>	l <sub>1</sub>	d <sub>1</sub>	l <sub>1</sub>	d <sub>1</sub>	l <sub>1</sub>		
23 + 24	130	240	110	205	90	170	510	Auf Anfrage On request Sur demande
25 + 26	150	245	130	245	100	210	570	

Größe Size Taille	Zahnradgetriebe / Gear units / Réducteurs à engrenages											
	b	c	c <sub>1</sub>	D <sub>5</sub>	g	h <sub>-1</sub>	h <sub>1</sub>	h <sub>2</sub>	m <sub>3</sub>	n <sub>1</sub>	n <sub>4</sub>	s
23 + 24	930	115	120 ± 2	80	342	780	770	790	810	180	580	56
25 + 26	1045	130	120 ± 2	90	400	860	860	860	910	200	660	66

Größe Size Taille	Zahnradgetriebe / Gear units / Réducteurs à engrenages									Rücklauf- sperre Backstop Antidévireur G <sub>8</sub>
	a	e <sub>2</sub>	E	f <sub>1</sub>	H	m <sub>1</sub>	m <sub>2</sub>	n <sub>2</sub>	n <sub>3</sub>	
23	2530	730	1505	35	1570	1085	1085	550	1725	Maße auf Anfrage Dimensions on request Dimensions sur demande
24	2660	795	1570	35	1570	1085	1215	615	1790	
25	2830	790	1695	65	1720	1215	1215	590	1965	
26	3010	880	1785	65	1720	1215	1395	680	2055	

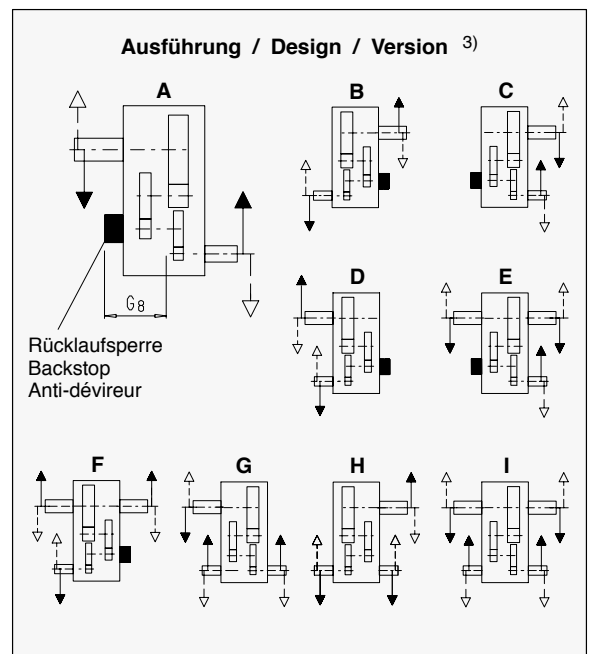

## Zahnradgetriebe

Dreistufig  
Horizontal  
Bauarten H3.H, H3DM  
Größen 23 - 26

## Gear Units

Three Stage  
Horizontal  
Types H3.H, H3DM  
Sizes 23 - 26

## Réducteurs à engrenages

à trois trains  
Horizontal  
Types H3.H, H3DM  
Tailles 23 - 26

### Abtrieb / Output / Sortie

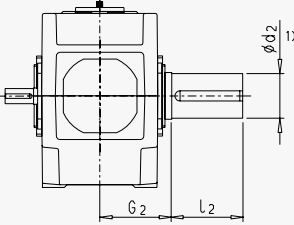
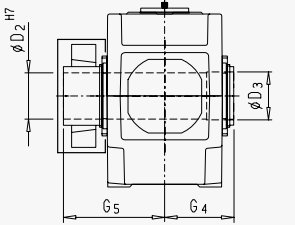
<b>H3SH</b> Vollwelle Solid shaft Arbre plein  	<b>H3DH, H3DM</b> Hohlwelle für Schrumpfscheibe Hollow shaft for shrink disk Arbre creux pour frette de serrage  
---	---

Größe Size Taille	H3SH			H3DH, H3DM			
	d <sub>2</sub>	l <sub>2</sub>	G <sub>2</sub>	D <sub>2</sub>	D <sub>3</sub>	G <sub>4</sub>	G <sub>5</sub>
23	360	590	540	360	365	540	785
24	380	590	540	380	385	540	805
25	400	650	605	400	405	605	875
26	420	650	605	430	435	605	900

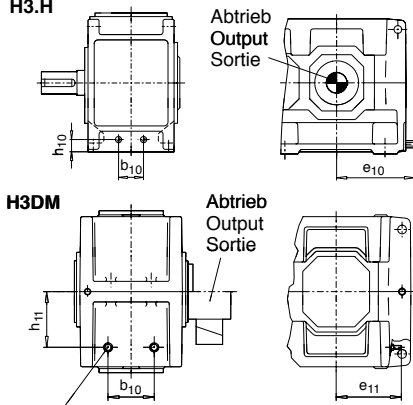
Größe Size Taille	Ölmenge Oil quantity Quantité de huile (l) *)		Gewicht Weight / Poids (kg) **) **)		Kühlschlange / Cooling coil Serpentin de refroidissement					
	H3SH	H3DM	H3SH H3DH	H3DM	b <sub>10</sub>	e <sub>10</sub>	e <sub>11</sub>	h <sub>10</sub>	h <sub>11</sub>	l/(min x)
23	620	690	11500	10600	 <p>Abtrieb Output Sortie</p> <p>Abtrieb Output Sortie</p> <p>Wasseranschluß für Kühlschlange G1/2" Water connection for cooling coil G1/2" Adduction pour serpentin de refroidissement G1/2"</p>					
24	650	725	13400	12500						
25	880	970	16100	15200						
26	935	1030	17600	16500						
					23	Auf Anfrage On request Sur demande				
					24					
					25					
					26					

Abmessungen in mm

#### 1) Wellen:

- m<sub>6</sub> <= Ø 100; n<sub>6</sub> > Ø 100
- Paßfedernut nach DIN 6885/1, Nabennutbreite nach ISO JS9
- Paßfeder nach DIN 6885/1 Form B
- Einzelheiten siehe Seiten 126 - 135

#### 3) Varianten:

- Rücklaufperre nicht in Verbindung mit Ausführung G, H, I.

\*) Richtwerte; genaue Angaben nach auftragsbezogener Dokumentation.

\*\*) ohne Ölfüllung

Dimensions in mm

#### 1) Shafts:

- m<sub>6</sub> <= Ø 100; n<sub>6</sub> > Ø 100
- Keyway acc. to DIN 6885/1, Hub keyway width acc. to ISO JS9
- Parallel key acc. to DIN 6885/1 form B
- For details, see pages 126 - 135

#### 3) Variants:

- Backstop not possible with G, H and I designs.

\*) Approximate values; exact data acc. to order-related documentation.

\*\*) Without oil filling

Dimensions en mm

#### 1) Arbres:

- m<sub>6</sub> <= Ø 100; n<sub>6</sub> > Ø 100
- Rainure de clavette selon DIN 6885/1, Tolérance dans le moyeu selon ISO JS9
- Clavette selon DIN 6885/1 forme B
- Détails voir pages 126 - 135

#### 3) Variantes:

- Impossibilité de monter un anti-dévireur avec les exécutions G, H et I.

\*) Valeurs approximatives; données exactes selon documentation relative à la commande.

\*\*) sans huile

# Zahnradgetriebe

Vierstufig  
Horizontal  
Bauart H4.H  
Größen 7 - 12

# Gear Units

Four Stage  
Horizontal  
Type H4.H  
Sizes 7 - 12

# Réducteurs à engrenages

à quatre trains  
Horizontal  
Type H4.H  
Tailles 7 - 12

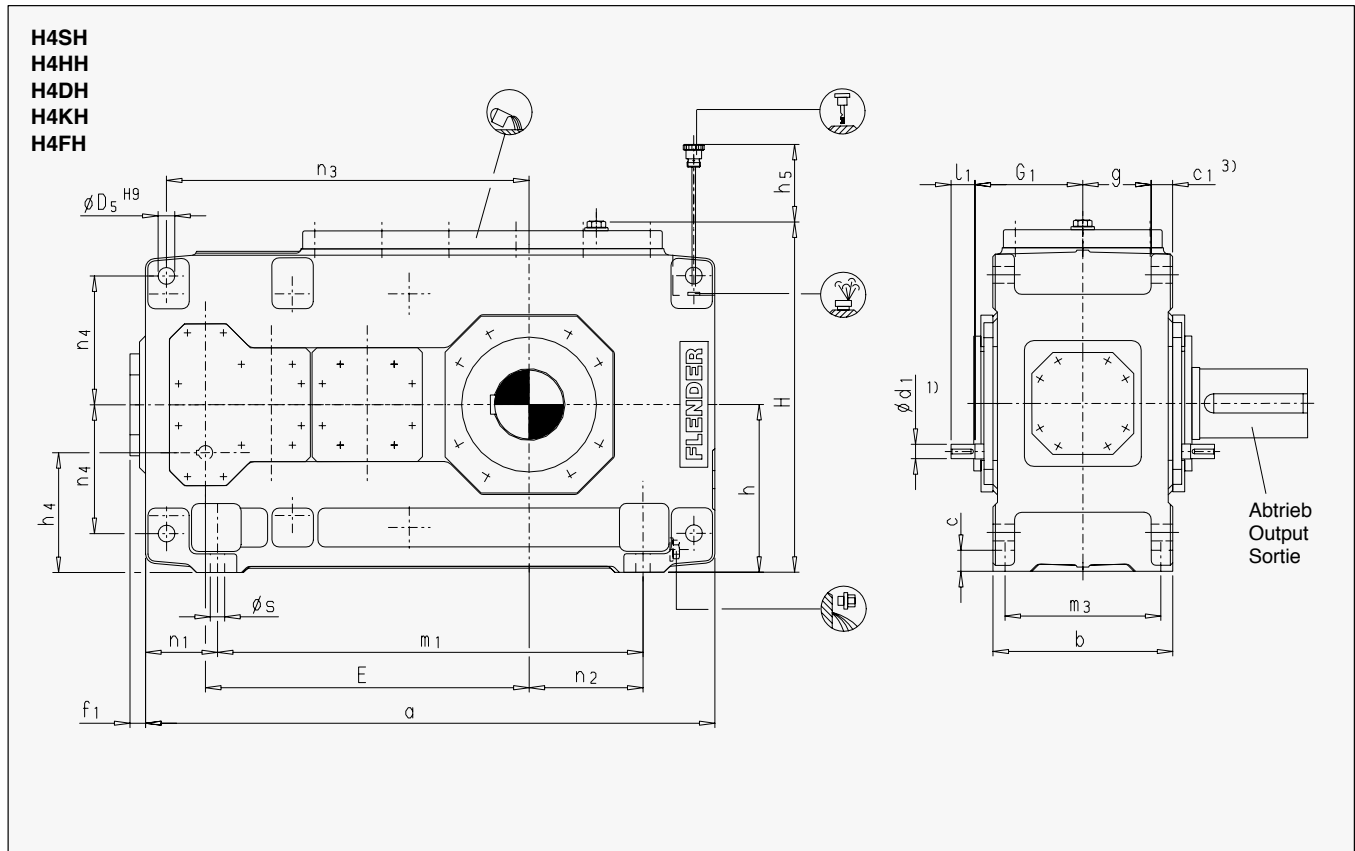

4

Größe Size Taille	Antrieb / Input / Entrée					3) Ausführung / Design Version <b>G, H, I</b> nur für / only for / seulement pour $i_N =$	
	$i_N = 100 - 180$		$i_N = 200 - 355$		$G_1$	100 - 224	125 - 280
	$d_1$	$l_1$	$d_1$	$l_1$			
7 + 8	30	50	24	40	180	100 - 224	125 - 280
9 + 10	35	60	28	50	215	100 - 250	125 - 315
11 + 12	45	100	32	80	250	100 - 250	125 - 315

Größe Size Taille	Zahnradgetriebe / Gear units / Réducteurs à engrenages										
	b	c	$c_1$	$D_5$	g	$h_{-1}$	$h_4$	$m_3$	$n_1$	$n_4$	s
7 + 8	300	35	$36 \pm 1$	28	114	280	200	260	120	215	24
9 + 10	370	40	$45 \pm 1.5$	36	140	320	230	320	145	245	28
11 + 12	430	50	$54 \pm 1.5$	40	161	380	270	370	165	300	35

Größe Size Taille	Zahnradgetriebe / Gear units / Réducteurs à engrenages								Rücklauf- sperre Backstop Anti-dévi- reur $G_8^{+})$
	a	E	$f_1$	$h_5$	H	$m_1$	$n_2$	$n_3$	
7	845	495	37	140	572	605	130	560	286
8	950	540	37	140	582	710	190	605	286
9	1000	580	43	150	662	710	155	660	317
10	1100	630	43	150	662	810	205	710	317
11	1200	705	47	165	782	870	180	805	333
12	1355	775	47	165	790	1025	265	875	333

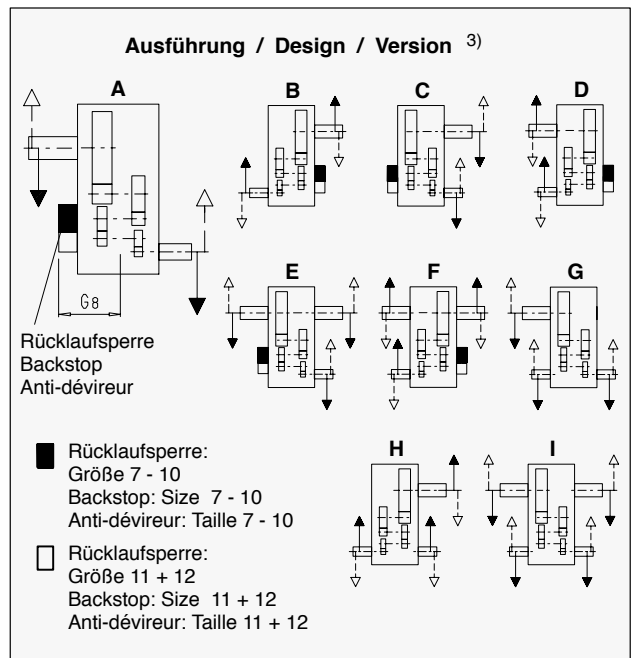

+) max. Abmessungen; Einzelheiten nach auf-  
tragsbezogener Dokumentation.

+) Max. dimensions; details acc. to order-related  
documentation.

+) Dimensions maximales; détails selon docu-  
mentation relative à la commande.

# Zahnradgetriebe

Vierstufig  
Horizontal  
Bauart H4.H  
Größen 7 - 12

# Gear Units

Four Stage  
Horizontal  
Type H4.H  
Sizes 7 - 12

# Réducteurs à engrenages

à quatre trains  
Horizontal  
Type H4.H  
Tailles 7 - 12

## Abtrieb / Output / Sortie

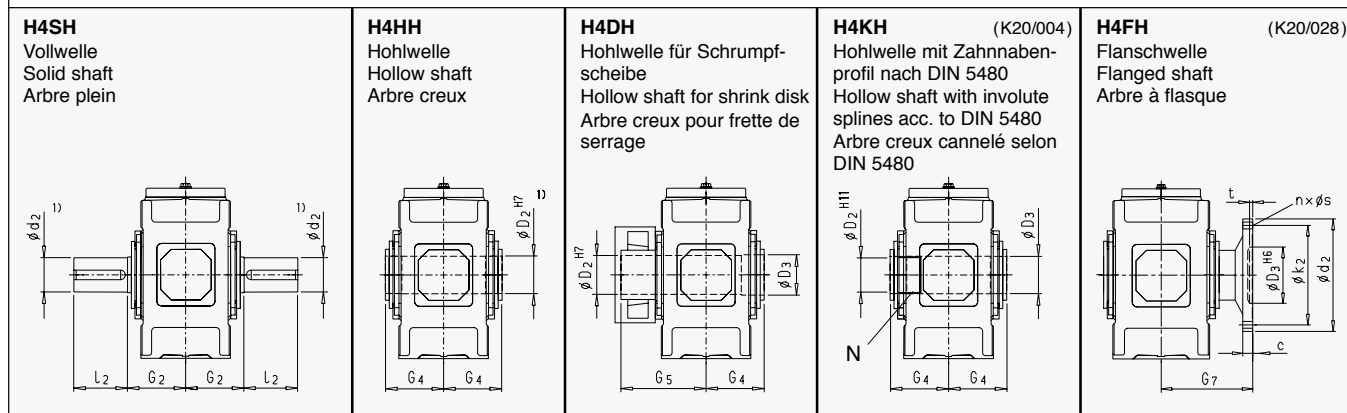

Größe Size Taille	H4SH			H4HH		H4DH				H4KH				H4FH							
	d <sub>2</sub>	l <sub>2</sub>	G <sub>2</sub>	D <sub>2</sub>	G <sub>4</sub>	D <sub>2</sub>	D <sub>3</sub>	G <sub>4</sub>	G <sub>5</sub>	N / DIN 5480		D <sub>2</sub>	D <sub>3</sub>	G <sub>4</sub>	c	d <sub>2</sub>	D <sub>3</sub>	k <sub>2</sub>	n x s	t	G <sub>7</sub>
7	120	210	195	115	195	120	120	195	280	N 120x3x30x38x9H		114	120	195	30	370	180	320	16 x 26	10	300
8	130	250	195	125	195	130	130	195	285	N 120x3x30x38x9H		114	130	195	30	390	190	340	18 x 26	10	300
9	140	250	235	135	235	140	145	235	330	N 140x3x30x45x9H		134	145	235	38	430	220	380	20 x 26	12	350
10	160	300	235	150	235	150	155	235	350	N 140x3x30x45x9H		134	155	235	38	470	240	420	22 x 26	12	350
11	170	300	270	165	270	165	170	270	400	N 170x5x30x32x9H		160	170	270	42	510	260	450	18 x 33	12	400
12	180	300	270	180	270	180	185	270	405	N 170x5x30x32x9H		160	185	270	42	540	280	480	22 x 33	12	400

Größe Size Taille	Ölmenge Oil quantity Quantité de huile (l) *)	Gewicht Weight / Poids (kg) *) **)	
		H4SH H4HH H4DH H4KH	H4FH
7	25	550	600
8	27	645	700
9	48	875	960
10	50	1010	1100
11	80	1460	1590
12	87	1725	1865

### Abmessungen in mm

#### 1) Wellen:

- $k_6 = \varnothing 24$ ;  $\varnothing 28 \geq m_6 \leq \varnothing 100$ ;  $n_6 > \varnothing 100$
- Paßfedernut nach DIN 6885/1, Nabennutbreite nach ISO JS9
- Paßfeder nach DIN 6885/1 Form B
- Einzelheiten siehe Seiten 126 - 135

#### 3) Varianten:

- Rücklaufsperrung nicht in Verbindung mit Ausführung G, H, I.

\*) Richtwerte; genaue Angaben nach auftragsbezogener Dokumentation.

\*\*\*) ohne Ölfüllung

### Dimensions in mm

#### 1) Shafts:

- $k_6 = \varnothing 24$ ;  $\varnothing 28 \geq m_6 \leq \varnothing 100$ ;  $n_6 > \varnothing 100$
- Keyway acc. to DIN 6885/1, Hub keyway width acc. to ISO JS9
- Parallel key acc. to DIN 6885/1 form B
- For details, see pages 126 - 135

#### 3) Variants:

- Backstop not possible with G, H and I designs.

\*) Approximate values; exact data acc. to order-related documentation.

\*\*\*) Without oil filling

### Dimensions en mm

#### 1) Arbres:

- $k_6 = \varnothing 24$ ;  $\varnothing 28 \geq m_6 \leq \varnothing 100$ ;  $n_6 > \varnothing 100$
- Rainure de clavette selon DIN 6885/1, Tolérance dans le moyeu selon ISO JS9
- Clavette selon DIN 6885/1 forme B
- Détails voir pages 126 - 135

#### 3) Variantes:

- Impossibilité de monter un anti-dévireur avec les exécutions G, H et I.

\*) Valeurs approximatives; données exactes selon documentation relative à la commande.

\*\*\*) sans huile



# Zahnradgetriebe

Vierstufig  
Horizontal  
Bauarten H4.H, H4.M  
Größen 13 - 22

# Gear Units

Four Stage  
Horizontal  
Types H4.H, H4.M  
Sizes 13 - 22

# Réducteurs à engrenages

à quatre trains  
Horizontal  
Types H4.H, H4.M  
Tailles 13 - 22

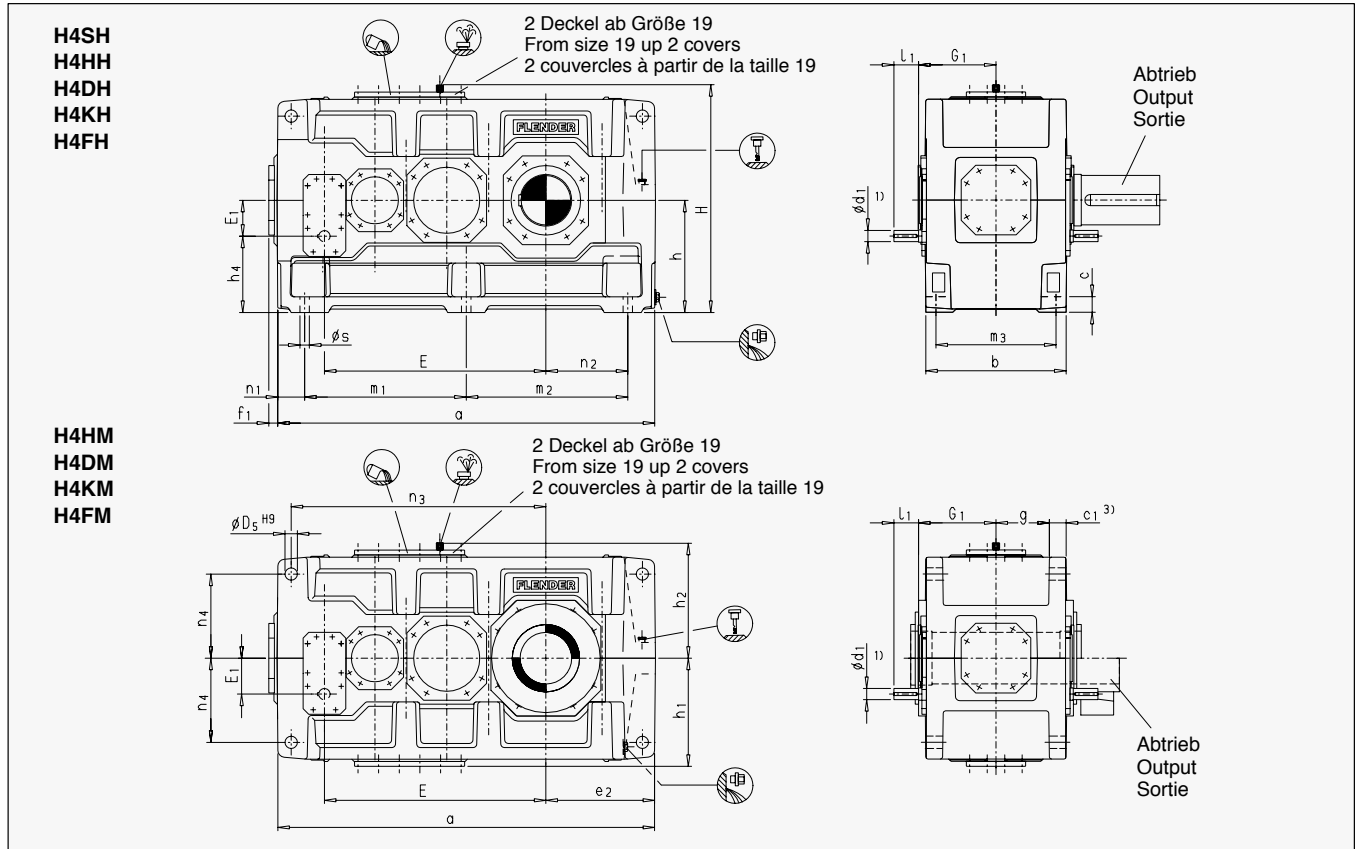

Größe Size Taille	Antrieb / Input / Entrée				G <sub>1</sub>	3) Ausführung / Design Version G, H, I nur für / only for / seulement pour i <sub>N</sub> =	
	i <sub>N</sub> = 100 - 180		i <sub>N</sub> = 200 - 355			100 - 250	125 - 315
	i <sub>N</sub> = 112 - 200		i <sub>N</sub> = 224 - 400				
	i <sub>N</sub> = 125 - 224		i <sub>N</sub> = 250 - 450				
	d <sub>1</sub>	l <sub>1</sub>	d <sub>1</sub>	l <sub>1</sub>			
13 + 14	50	100	38	80	305		
15 + 16	60	135	50	110	345		
17 + 18	60	105	50	80	380		
19 + 20	75	105	60	105	440		
21 + 22	90	165	70	140	460		

Größe Size Taille	Zahnradgetriebe / Gear units / Réducteurs à engrenages												
	b	c	c <sub>1</sub>	D <sub>5</sub>	g	h <sub>-1</sub>	h <sub>1</sub>	h <sub>4</sub>	h <sub>2</sub>	m <sub>3</sub>	n <sub>1</sub>	n <sub>4</sub>	s
13 + 14	550	60	61 ± 2	48	211.5	440	450	310	460	475	100	340	35
15 + 16	625	70	72 ± 2	55	238	500	490	340	500	535	120	375	42
17 + 18	690	80	81 ± 2	55	259	550	555	390	560	600	135	425	42
19 + 20	790	90	91 ± 2	65	299	620	615	435	620	690	155	475	48
21 + 22	830	100	100 ± 2	75	310	700	685	475	690	720	170	520	56

Größe Size Taille	Zahnradgetriebe / Gear units / Réducteurs à engrenages										
	a	e <sub>2</sub>	E	E <sub>1</sub>	f <sub>1</sub>	H	m <sub>1</sub>	m <sub>2</sub>	n <sub>2</sub>	n <sub>3</sub>	Rücklaufsperre Backstop / Anti- dévireur G <sub>8</sub> <sup>+) </sup>
13	1395	405	820	130	47	900	597.5	597.5	305	940	391
14	1535	475	890	130	47	900	597.5	737.5	375	1010	391
15	1680	485	987	160	56	1000	720	720	365	1135	487
16	1770	530	1033	160	56	1000	720	810	410	1180	487
17	1770	525	1035	160	53	1110	750	750	390	1175	487
18	1890	585	1095	160	53	1110	750	870	450	1235	487
19	2030	590	1190	185	53	1240	860	860	435	1365	590
20	2150	650	1250	185	53	1240	860	980	495	1425	590
21	2340	655	1387	225	62	1390	1000	1000	485	1600	610
22	2450	710	1442	225	62	1390	1000	1110	540	1655	610

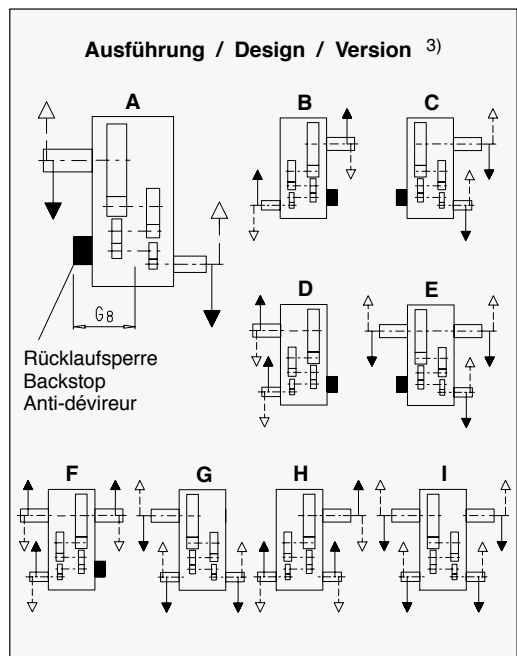

+) max. Abmessungen; Einzelheiten nach auftragsbezogener Dokumentation.

+) Max. dimensions; details acc. to order-related documentation.

+) Dimensions maximales; détails selon documentation relative à la commande.

# Zahnradgetriebe

Vierstufig  
Horizontal  
Bauarten H4.H, H4.M  
Größen 13 - 22

# Gear Units

Four Stage  
Horizontal  
Types H4.H, H4.M  
Sizes 13 - 22

# Réducteurs à engrenages

à quatre trains  
Horizontal  
Types H4.H, H4.M  
Tailles 13 - 22

## Abtrieb / Output / Sortie

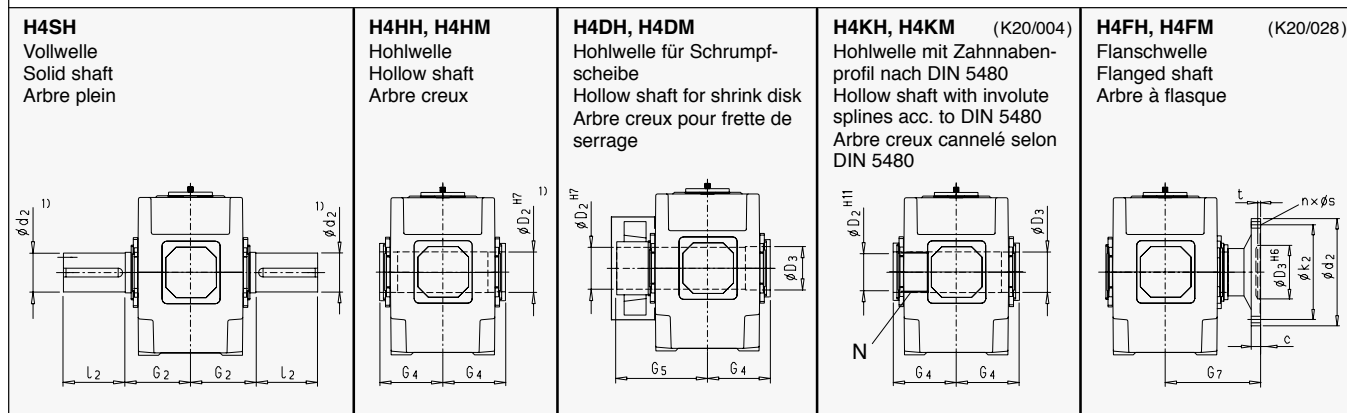

Größe Size Taille	H4SH			H4HH, H4HM		H4DH, H4DM				H4KH, H4KM				H4FH, H4FM									
	d <sub>2</sub>	l <sub>2</sub>	G <sub>2</sub>	D <sub>2</sub>	G <sub>4</sub>	D <sub>2</sub>	D <sub>3</sub>	G <sub>4</sub>	G <sub>5</sub>	N / DIN 5480				c	d <sub>2</sub>	D <sub>3</sub>	k <sub>2</sub>	n x s	t	G <sub>7</sub>			
13	200	350	335	190	335	190	195	335	480	N 190x5x30x36x9H				180	195	335	48	580	310	500	20 x 33	14	480
14	210	350	335	210	335	210	215	335	480	N 190x5x30x36x9H				180	215	335	48	620	310	540	24 x 33	14	480
15	230	410	380	230	380	230	235	380	550	N 220x5x30x42x9H				210	235	380	55	710	360	630	28 x 33	17	550
16	240	410	380	240	380	240	245	380	550	N 220x5x30x42x9H				210	245	380	55	740	360	660	30 x 33	17	550
17	250	410	415	250	415	250	260	415	600	N 250x5x30x48x9H				240	260	415	60	750	410	660	24 x 39	18	600
18	270	470	415	275	415	280	285	415	600	N 250x5x30x48x9H				240	285	415	60	800	410	710	26 x 39	18	600
19	290	470	465	-	-	285	295	465	670	Auf Anfrage On request Sur demande				65	860	460	770	30 x 39	18	670			
20	300	500	465	-	-	310	315	465	670					65	930	460	830	32 x 39	18	670			
21	320	500	490	-	-	330	335	490	715					75	950	520	850	28 x 45	20	710			
22	340	550	490	-	-	340	345	490	725					75	1040	520	940	28 x 45	20	710			

Größe Size Taille	Ölmenge Oil quantity Quantité de huile (l) *)		Gewicht Weight / Poids (kg) **)			
	H4.H	H4.M	H4SH H4HH H4DH H4KH	H4HM H4KM H4DM	H4FH	H4FM
13	130	120	2390	2270	2550	2430
14	140	125	2730	2600	2900	2770
15	230	170	3635	3440	3875	3680
16	235	175	3965	3740	4220	3995
17	290	225	4680	4445	4980	4745
18	305	230	5185	4915	5535	5265
19	430	310	6800	6300	Auf Anfrage On request Sur demande	
20	380	330	8200	7700		
21	395	430	9200	8600		
22	420	450	9900	9400		

### Abmessungen in mm

#### 1) Wellen:

- $m_6 \leq \varnothing 100$ ;  $n_6 > \varnothing 100$
- Paßfedernut nach DIN 6885/1, Nabennutbreite nach ISO JS9
- Paßfeder nach DIN 6885/1 Form B
- Einzelheiten siehe Seiten 126 - 135

#### 3) Varianten:

- Rücklaufsperre nicht in Verbindung mit Ausführung G, H, I.

\*) Richtwerte; genaue Angaben nach auftragsbezogener Dokumentation.

\*\*) ohne Ölfüllung

### Dimensions in mm

#### 1) Shafts:

- $m_6 \leq \varnothing 100$ ;  $n_6 > \varnothing 100$
- Keyway acc. to DIN 6885/1, Hub keyway width acc. to ISO JS9
- Parallel key acc. to DIN 6885/1 form B
- For details, see pages 126 - 135

#### 3) Variants:

- Backstop not possible with G, H and I designs.

\*) Approximate values; exact data acc. to order-related documentation.

\*\*) Without oil filling

### Dimensions en mm

#### 1) Arbres:

- $m_6 \leq \varnothing 100$ ;  $n_6 > \varnothing 100$
- Rainure de clavette selon DIN 6885/1, Tolérance dans le moyeu selon ISO JS9
- Clavette selon DIN 6885/1 forme B
- Détails voir pages 126 - 135

#### 3) Variantes:

- Impossibilité de monter un anti-dévireur avec les exécutions G, H et I.

\*) Valeurs approximatives; données exactes selon documentation relative à la commande.

\*\*) sans huile



# Zahnradgetriebe

Vierstufig  
Horizontal  
Bauarten H4.H, H4DM  
Größen 23 - 26

# Gear Units

Four Stage  
Horizontal  
Types H4.H, H4DM  
Sizes 23 - 26

# Réducteurs à engrenages

à quatre trains  
Horizontal  
Types H4.H, H4DM  
Tailles 23 - 26

H4SH  
H4DH

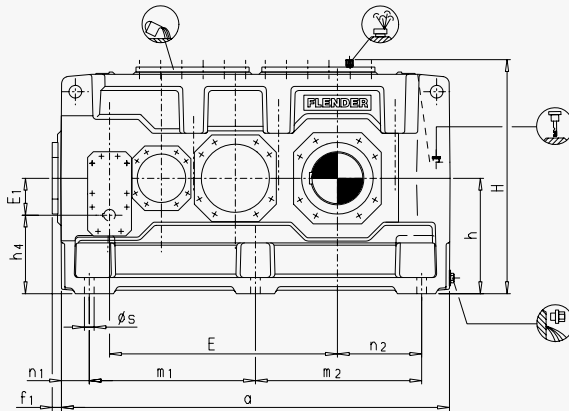

H4DM

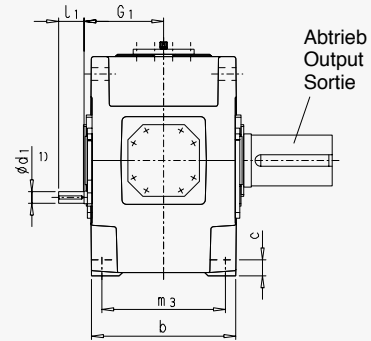
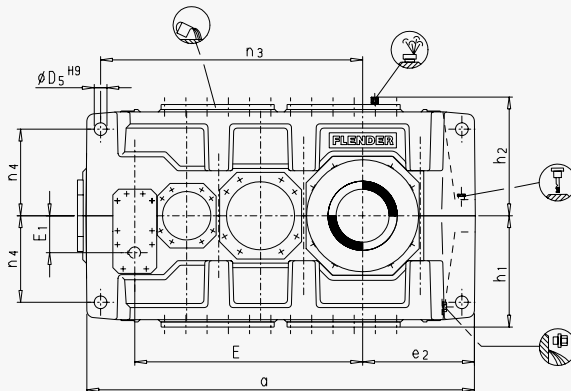

Abtrieb  
Output  
Sortie

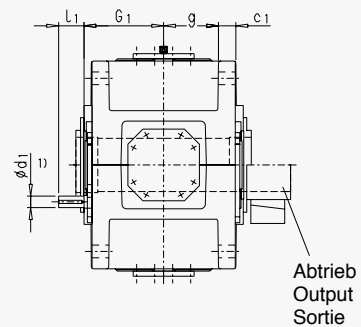

Abtrieb  
Output  
Sortie

Größe Size Taille	Antrieb / Input / Entrée				
	$i_N = 100 - 180$		$i_N = 200 - 355$		$G_1$
	$d_1$	$l_1$	$d_1$	$l_1$	
23 + 24	90	130	70	105	505
25 + 26	100	205	85	170	565

Größe Size Taille	Zahnradgetriebe / Gear units / Réducteurs à engrenages												
	b	c	$c_1$	$D_5$	g	$h_{-1}$	$h_1$	$h_2$	$h_4$	$m_3$	$n_1$	$n_4$	s
23 + 24	930	115	$120 \pm 2$	80	342	780	770	790	555	810	180	580	56
25 + 26	1045	130	$120 \pm 2$	90	400	860	860	860	595	910	200	660	66

Größe Size Taille	Zahnradgetriebe / Gear units / Réducteurs à engrenages										Rücklauf- sperre Backstop Antidévireur $G_8$
	a	$e_2$	E	$E_1$	$f_1$	H	$m_1$	$m_2$	$n_2$	$n_3$	
23	2530	730	1505	225	35	1570	1085	1085	550	1725	Maße auf Anfrage Dimensions on request Dimensions sur demande
24	2660	795	1570	225	35	1570	1085	1215	615	1790	
25	2830	790	1695	265	65	1720	1215	1215	590	1965	
26	3010	880	1785	265	65	1720	1215	1395	680	2055	

## Ausführung / Design / Version

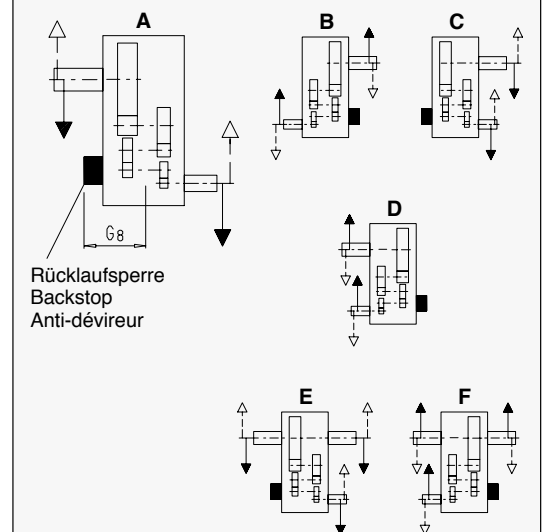

Rücklaufsperre  
Backstop  
Anti-dévireur



## Zahnradgetriebe

Vierstufig  
Horizontal  
Bauarten H4.H, H4DM  
Größen 23 - 26

## Gear Units

Four Stage  
Horizontal  
Types H4.H, H4DM  
Sizes 23 - 26

## Réducteurs à engrenages

à quatre trains  
Horizontal  
Types H4.H, H4DM  
Tailles 23 - 26

### Abtrieb / Output / Sortie

#### H4SH

Vollwelle  
Solid shaft  
Arbre plein

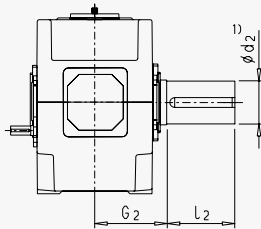

#### H4DH, H4DM

Hohlwelle für Schrumpfscheibe  
Hollow shaft for shrink disk  
Arbre creux pour frette de serrage

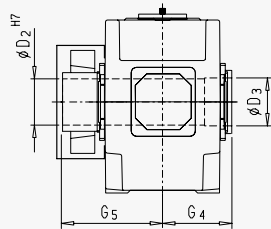

Größe Size Taille	H4SH			H4DH, H4DM			
	$d_2$	$l_2$	$G_2$	$D_2$	$D_3$	$G_4$	$G_5$
23	360	590	540	360	365	540	785
24	380	590	540	380	385	540	805
25	400	650	605	400	405	605	875
26	420	650	605	430	435	605	900

Größe Size Taille	Ölmenge Oil quantity Quantité de huile (l) *)		Gewicht Weight / Poids (kg) *) **)	
	H4SH	H4DM	H4SH H4DH	H4DM
23	520	500	11600	10700
24	550	600	13500	12600
25	735	800	16100	15200
26	780	850	17600	16500

Abmessungen in mm

#### 1) Wellen:

- $m_6 \leq \phi 100$ ;  $n_6 > \phi 100$
- Paßfedernut nach DIN 6885/1, Nabennutbreite nach ISO JS9
- Paßfeder nach DIN 6885/1 Form B
- Einzelheiten siehe Seiten 126 - 135

\*) Richtwerte; genaue Angaben nach auftragsbezogener Dokumentation.

\*\*) ohne Ölfüllung

Dimensions in mm

#### 1) Shafts:

- $m_6 \leq \phi 100$ ;  $n_6 > \phi 100$
- Keyway acc. to DIN 6885/1, Hub keyway width acc. to ISO JS9
- Parallel key acc. to DIN 6885/1 form B
- For details, see pages 126 - 135

\*) Approximate values; exact data acc. to order-related documentation.

\*\*) Without oil filling

Dimensions en mm

#### 1) Arbres:

- $m_6 \leq \phi 100$ ;  $n_6 > \phi 100$
- Rainure de clavette selon DIN 6885/1, Tolérance dans le moyeu selon ISO JS9
- Clavette selon DIN 6885/1 forme B
- Détails voir pages 126 - 135

\*) Valeurs approximatives; données exactes selon documentation relative à la commande.

\*\*) sans huile

# Zahnradgetriebe

Zweistufig  
Horizontal  
Bauart B2.H  
Größen 4 - 12

# Gear Units

Two Stage  
Horizontal  
Type B2.H  
Sizes 4 - 12

# Réducteurs à engrenages

à deux trains  
Horizontal  
Type B2.H  
Tailles 4 - 12

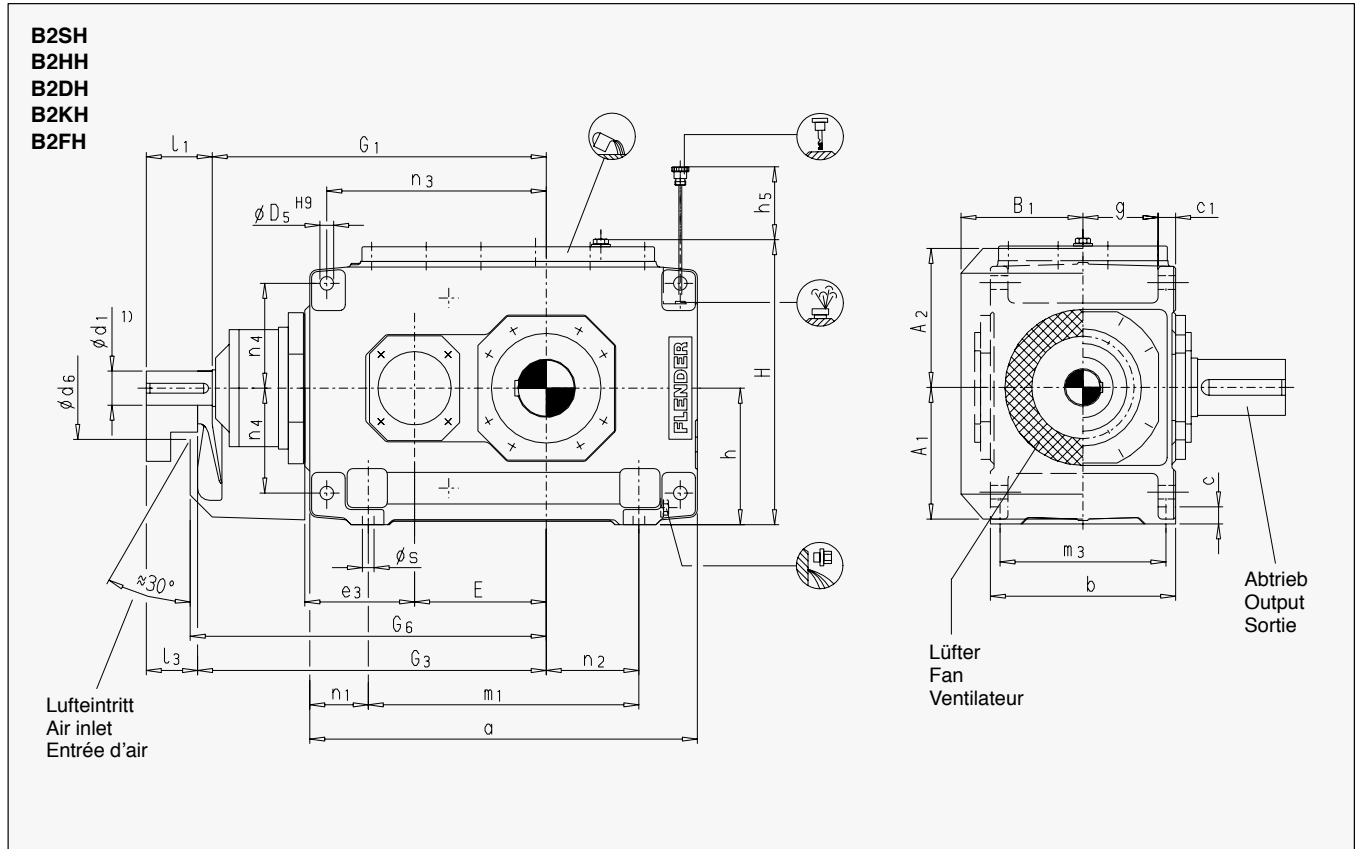

Größe Size Taille	Antrieb / Input Entrée			Lüfter / Fan / Ventilateur							
	$i_N = 5 - 11.2$			$G_1$	$G_3$	$G_1$	$G_3$	$A_1$	$A_2$	$B_1$	$d_6$
	$d_1$	$l_1$	$l_3$								
4	45	100	80	465	485	-	-	195	200	188	150
5 + 6	55	110	80	535	565	570	600	220	235	215	160
7 + 8	70	135	105	640	670	685	715	270	285	250	210
9 + 10	80	165	130	755	790	805	840	310	325	270	195
11 + 12	90	165	130	925	960	995	1030	370	385	328	210

Größe Size Taille	Zahnradgetriebe / Gear units / Réducteurs à engrenages										
	$b$	$c$	$c_1$	$D_5$	$e_3$	$g$	$h_{-1}$	$m_3$	$n_1$	$n_4$	$s$
4	270	28	$30 \pm 1$	24	160	105	200	235	105	150	19
5 + 6	320	28	$30 \pm 1$	24	185	130	230	285	105	180	19
7 + 8	380	35	$36 \pm 1$	28	225	154	280	340	120	215	24
9 + 10	440	40	$48 \pm 1.5$	36	265	172	320	390	145	245	28
11 + 12	530	50	$54 \pm 1.5$	40	320	211	380	470	165	300	35

Größe Size Taille	Zahnradgetriebe / Gear units / Réducteurs à engrenages								
	$a$	$E$	$G_6$	$h_5$	$H$	$m_1$	$n_2$	$n_3$	Rücklaufsperre Backstop / Anti-déviereur $G_8$ *)
4	505	160	495	80	415	295	85	285	284
5	565	185	575	150	482	355	100	330	323
6	645	220	610	150	482	435	145	365	323
7	690	225	685	180	582	450	130	405	375
8	795	270	730	190	582	555	190	450	375
9	820	265	805	205	662	530	155	480	452
10	920	315	855	215	662	630	205	530	452
11	975	320	980	240	790	645	180	580	497
12	1130	390	1050	250	790	800	265	650	497

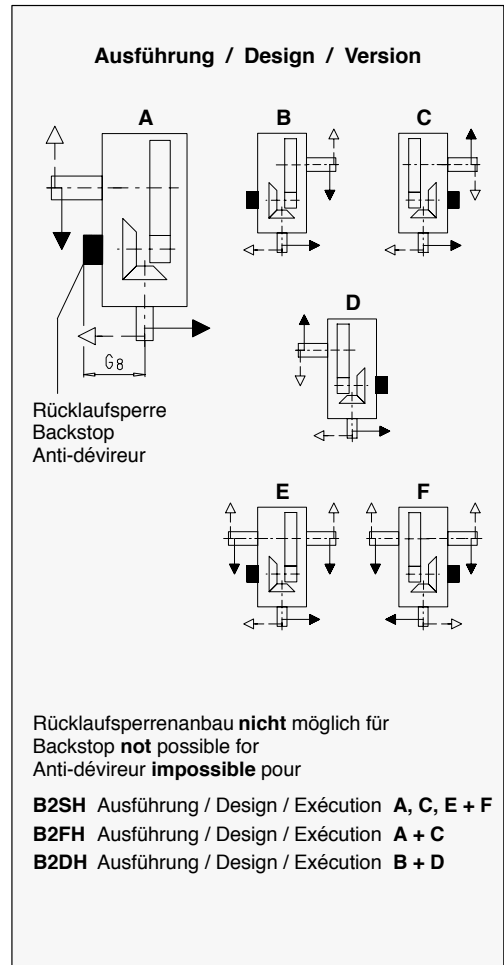

+) max. Abmessungen; Einzelheiten nach auftragsbezogener Dokumentation.

+) Max. dimensions; details acc. to order-related documentation.

+) Dimensions maximales; détails selon documentation relative à la commande.

# Zahnradgetriebe

Zweistufig  
Horizontal  
Bauart B2.H  
Größen 4 - 12

# Gear Units

Two Stage  
Horizontal  
Type B2.H  
Sizes 4 - 12

# Réducteurs à engrenages

à deux trains  
Horizontal  
Type B2.H  
Tailles 4 - 12

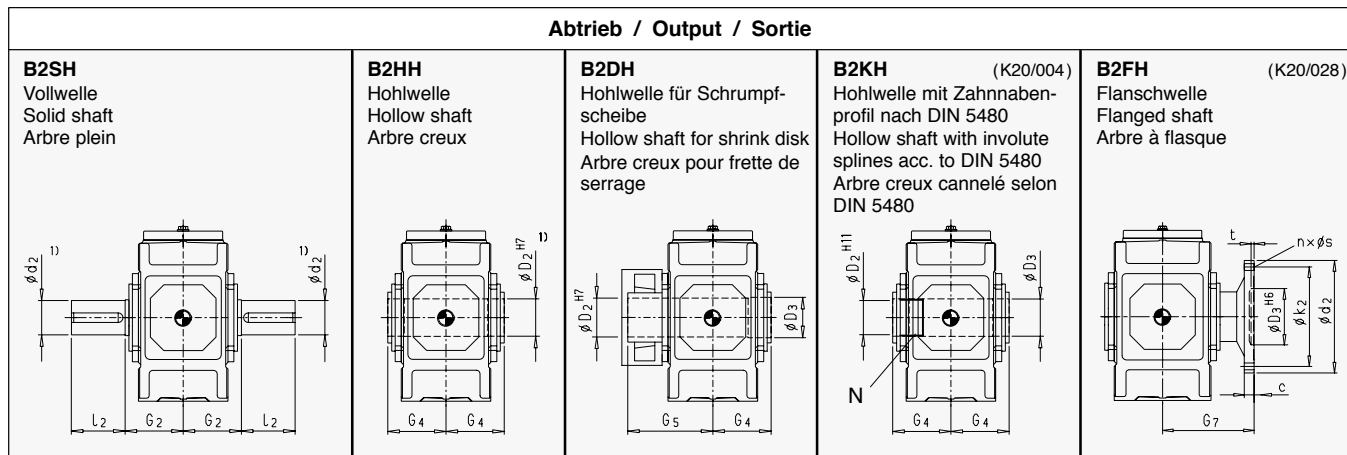

Größe Size Taille	B2SH			B2HH		B2DH				B2KH				B2FH										
	d <sub>2</sub>	l <sub>2</sub>	G <sub>2</sub>	D <sub>2</sub>	G <sub>4</sub>	D <sub>2</sub>	D <sub>3</sub>	G <sub>4</sub>	G <sub>5</sub>	N / DIN 5480				D <sub>2</sub>	D <sub>3</sub>	G <sub>4</sub>	c	d <sub>2</sub>	D <sub>3</sub>	k <sub>2</sub>	n x s	t	G <sub>7</sub>	
4	80	170	170	80	170	85	85	170	235	-				-	-	-	-	-	-	-	-	-	-	-
5	100	210	200	95	200	100	100	200	275	N 95x3x30x30x9H				89	100	200	25	300	150	260	16 x 22	10	290	
6	110	210	200	105	200	110	110	200	275	N 95x3x30x30x9H				89	110	200	25	320	160	280	18 x 22	10	290	
7	120	210	235	115	235	120	120	235	320	N 120x3x30x38x9H				114	120	235	30	370	180	320	16 x 26	10	340	
8	130	250	235	125	235	130	130	235	325	N 120x3x30x38x9H				114	130	235	30	390	190	340	18 x 26	10	340	
9	140	250	270	135	270	140	145	270	365	N 140x3x30x45x9H				134	145	270	38	430	220	380	20 x 26	12	385	
10	160	300	270	150	270	150	155	270	385	N 140x3x30x45x9H				134	155	270	38	470	240	420	22 x 26	12	385	
11	170	300	320	165	320	165	170	320	450	N 170x5x30x32x9H				160	170	320	42	510	260	450	18 x 33	12	450	
12	180	300	320	180	320	180	185	320	455	N 170x5x30x32x9H				160	185	320	42	540	280	480	22 x 33	12	450	

Größe Size Taille	Ölmenge Oil quantity Quantité de huile (l) *)	Gewicht Weight / Poids (kg) *) **)		Kühlschlange / Cooling coil Serpentin de refroidissement		Abtrieb / Output / Sortie	Größe Size Taille			
		B2SH B2HH B2DH B2KH	B2FH	b <sub>10</sub>	e <sub>10</sub>		h <sub>10</sub>	l/(min x)		
4	10	235	-	Wasseranschluß für Kühlschlange G1/2"		4 74 160 54 4				
5	16	360	400	Water connection for cooling coil G1/2"		5 130 175 62 8				
6	19	410	455	Adduction pour serpentin de refroidissement G1/2"		6 120 220 68 4				
7	31	615	670	Kühlschlange geeignet für Süß-, See- und Brackwasser Cooling coil suitable for fresh, sea and brackish water Serpentin de refroidissement adapté à l'eau douce, de mer et saumâtre		7 140 210 80 8				
8	34	700	760			8 140 270 80 4				
9	48	1000	1090	x) Erforderliche Kühlwassermenge, max. Kühlwasserdruck: 8 bar Cooling water quantity required; max. cooling water pressure: 8 bar Quantité d'eau de refroidissement nécessaire		9 232 245 110 8				
10	50	1155	1250			10 150 295 90 8				
11	80	1640	1775			11 312 275 115 8				
12	95	1910	2060			12 300 360 115 8				

Abmessungen in mm

Dimensions in mm

Dimensions en mm

**1) Wellen:**

- m<sub>6</sub> ≤ ∅ 100; n<sub>6</sub> > ∅ 100
- Paßfedernut nach DIN 6885/1, Nabennutbreite nach ISO JS9
- Paßfeder nach DIN 6885/1 Form B
- Einzelheiten siehe Seiten 126 - 135

**1) Shafts:**

- m<sub>6</sub> ≤ ∅ 100; n<sub>6</sub> > ∅ 100
- Keyway acc. to DIN 6885/1, Hub keyway width acc. to ISO JS9
- Parallel key acc. to DIN 6885/1 form B
- For details, see pages 126 - 135

**1) Arbres:**

- m<sub>6</sub> ≤ ∅ 100; n<sub>6</sub> > ∅ 100
- Rainure de clavette selon DIN 6885/1, Tolérance dans le moyeu selon ISO JS9
- Clavette selon DIN 6885/1 forme B
- Détails voir pages 126 - 135

\*) Richtwerte; genaue Angaben nach auftragsbezogener Dokumentation.

\*) Approximate values; exact data acc. to order-related documentation.

\*) Valeurs approximatives; données exactes selon documentation relative à la commande.

\*\*) ohne Ölfüllung

\*\*) Without oil filling

\*\*) sans huile



# Zahnradgetriebe

Zweistufig  
Horizontal  
Bauarten B2.H, B2.M  
Größen 13 - 18

# Gear Units

Two Stage  
Horizontal  
Types B2.H, B2.M  
Sizes 13 - 18

# Réducteurs à engrenages

à deux trains  
Horizontal  
Types B2.H, B2.M  
Tailles 13 - 18

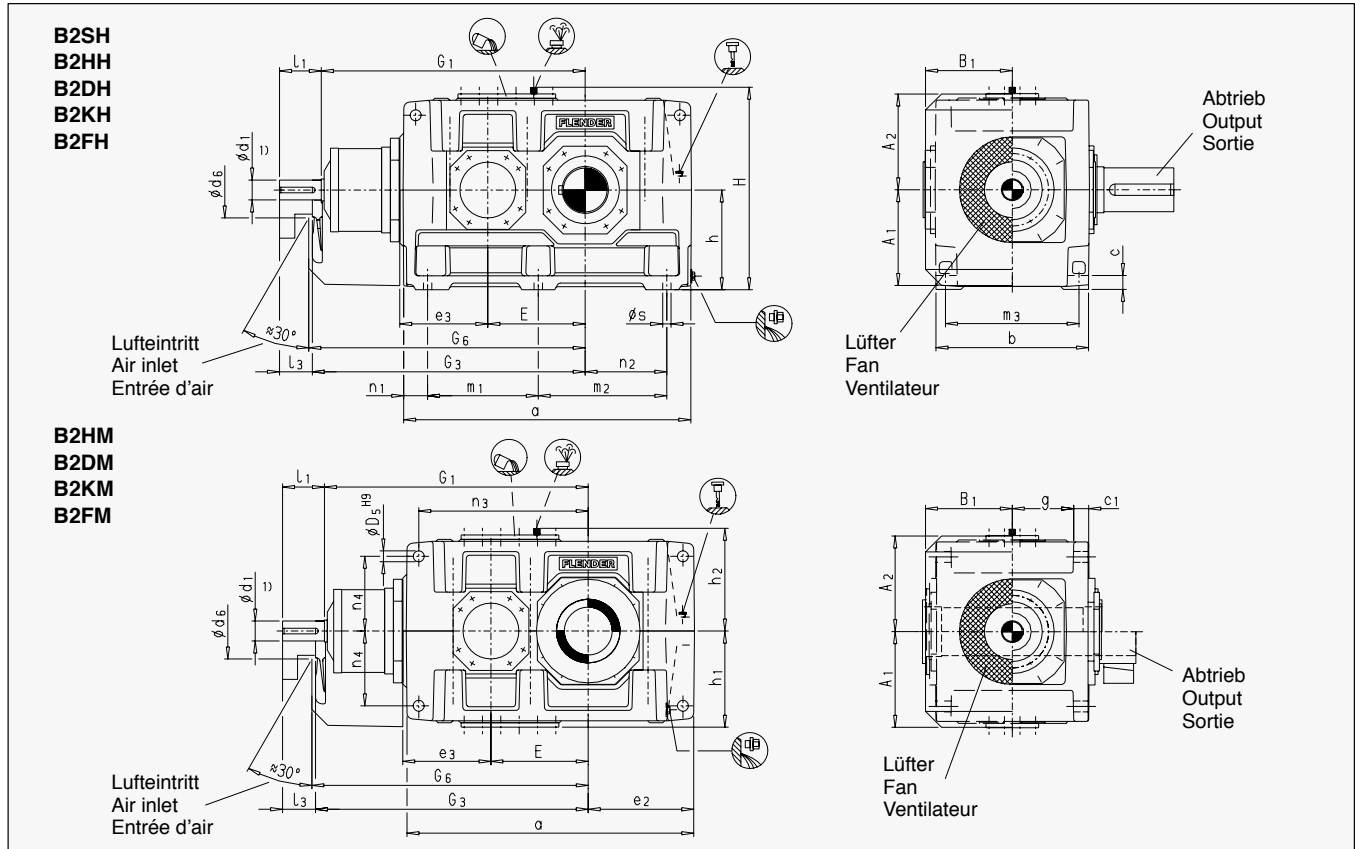

4

Größe Size Taille	Antrieb / Input / Entrée						Lüfter / Fan Ventilateur							
	$i_N = 5 - 11.2$			$i_N = 5.6 - 11.2$			$G_1$	$G_3$	$G_1$	$G_3$	$A_1$	$A_2$	$B_1$	$d_6$
	$d_1$	$l_1$	$l_3$	$d_1$	$l_1$	$l_3$								
							$i_N = 7.1 - 12.5$							
13 + 14	110	205	165				1070	1110	1140	1180	430	450	375	245
15	130	245	200				1277	1322			490	495	435	280
16				130	245	200			1323	1368	490	495	435	280
17				150	245	200	1435	1480			540	555	505	380
18	150	245	200				1495	1540			540	555	505	380

Größe Size Taille	Zahnradgetriebe / Gear units / Réducteurs à engrenages												
	b	c	$c_1$	$D_5$	$e_3$	g	$h_{-1}$	$h_1$	$h_2$	$m_3$	$n_1$	$n_4$	s
13 + 14	655	60	$61 \pm 2$	48	380	264	440	450	460	580	100	340	35
15 + 16	765	70	$72 \pm 2$	55	450	308	500	490	500	670	120	375	42
17 + 18	885	80	$81 \pm 2$	65	510	356	550	555	560	780	135	420	48

Größe Size Taille	Zahnradgetriebe / Gear units / Réducteurs à engrenages									
	a	$e_2$	E	$G_6$	H	$m_1$	$m_2$	$n_2$	$n_3$	Rücklaufsperre Backstop / Anti-dévi- vireur $G_8$ *)
13	1130	405	370	1130	900	465	465	305	675	559
14	1270	475	440	1200	900	465	605	375	745	559
15	1350	485	442	1340	1000	555	555	365	805	585
16	1440	530	488	1385	1000	555	645	410	850	585
17	1490	525	490	1500	1110	610	610	390	895	703
18	1610	585	550	1560	1110	610	730	450	955	703

- +) max. Abmessungen; Einzelheiten nach auftragsbezogener Dokumentation.
- +) Max. dimensions; details acc. to order-related documentation.
- +) Dimensions maximales; détails selon documentation relative à la commande.

**Ausführung / Design / Version**

Rücklaufsperre  
Backstop  
Anti-dévi-  
vireur

- Rücklaufsperre: Größe 13 - 14  
Backstop: Size 13 - 14  
Anti-dévi-  
vireur: Taille 13 - 14
- Rücklaufsperre: Größe 15 - 18  
Backstop: Size 15 - 18  
Anti-dévi-  
vireur: Taille 15 - 18

Rücklaufsperrenanbau **nicht** möglich für  
Backstop **not** possible for  
Anti-dévi-  
vireur **impossible** pour

**B2SH** Größe / Size / Taille 13 + 14  
Ausführung / Design / Exécution **A, C, E + F**

**B2SH** Größe / Size / Taille 15 - 18  
Ausführung / Design / Exécution **B, D, E + F**

**B2FH** Größe / Size / Taille 13 + 14  
Ausführung / Design / Exécution **A + C**

**B2FH** Größe / Size / Taille 15 - 18  
Ausführung / Design / Exécution **B + D**

**B2DH** Größe / Size / Taille 14  
Ausführung / Design / Exécution **B + D**

**B2DH** Größe / Size / Taille 16 + 18  
Ausführung / Design / Exécution **A + C**

# Zahnradgetriebe

Zweistufig  
Horizontal  
Bauarten B2.H, B2.M  
Größen 13 - 18

# Gear Units

Two Stage  
Horizontal  
Types B2.H, B2.M  
Sizes 13 - 18

# Réducteurs à engrenages

à deux trains  
Horizontal  
Types B2.H, B2.M  
Tailles 13 - 18

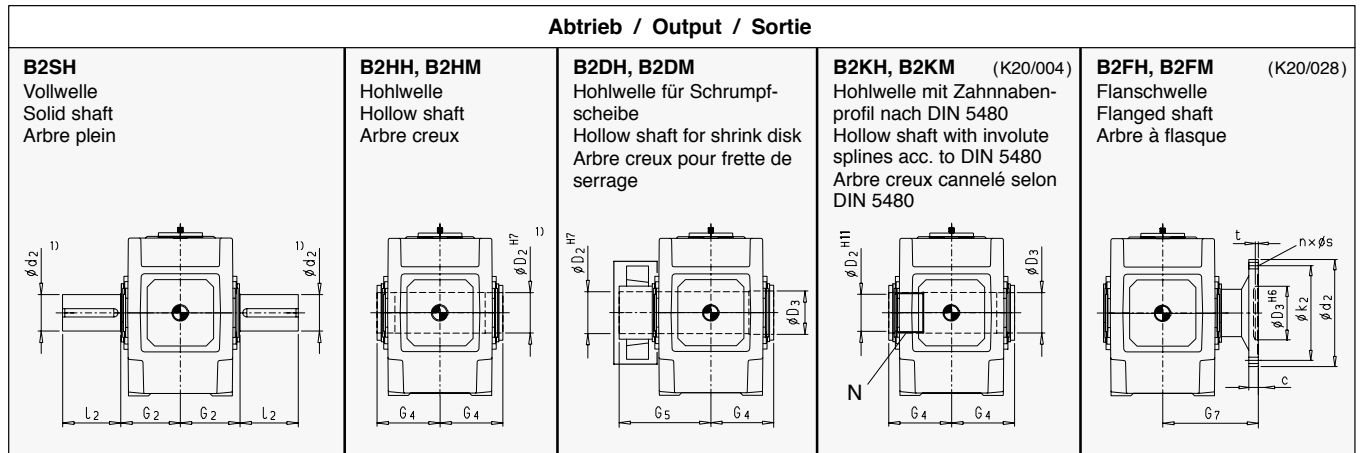

Größe Size Taille	B2SH			B2HH, B2HM		B2DH, B2DM				B2KH, B2KM				B2FH, B2FM								
	d <sub>2</sub>	l <sub>2</sub>	G <sub>2</sub>	D <sub>2</sub>	G <sub>4</sub>	D <sub>2</sub>	D <sub>3</sub>	G <sub>4</sub>	G <sub>5</sub>	N / DIN 5480			D <sub>2</sub>	D <sub>3</sub>	G <sub>4</sub>	c	d <sub>2</sub>	D <sub>3</sub>	k <sub>2</sub>	n x s	t	G <sub>7</sub>
13	200	350	390	-	-	-	-	-	-	-	-	-	-	-	-	48	580	310	500	20 x 33	14	525
14	210	350	390	210	390	210	215	390	535	N 190x5x30x36x9H	180	215	390	48	620	310	540	24 x 33	14	525		
15	230	410	460	-	-	-	-	-	-	-	-	-	-	-	-	55	710	360	630	28 x 33	17	625
16	240	410	460	240	450	240	245	450	620	N 220x5x30x42x9H	210	245	450	55	740	360	660	30 x 33	17	625		
17	250	410	540	-	-	-	-	-	-	-	-	-	-	-	-	60	750	410	660	24 x 39	18	695
18	270	470	540	275	510	280	285	510	700	N 250x5x30x48x9H	240	285	510	60	800	410	710	26 x 39	18	695		

Größe Size Taille	Ölmenge Oil quantity Quantité de huile (l) *)		Gewicht Weight / Poids (kg) *) **)				Kühlschlange / Cooling coil Serpentin de refroidissement		Größe Size Taille							
	B2.H	B2.M	B2SH B2HH B2DH B2KH	B2HM B2KM B2DM	B2FH	B2FM			b <sub>10</sub>	b <sub>11</sub>	e <sub>10</sub>	e <sub>11</sub>	h <sub>10</sub>	h <sub>11</sub>	l/(min x)	
13	140	120	2450	2350	2620	2520	<p>Wasseranschluß für Kühlschlange G1/2" Water connection for cooling coil G1/2" Adduction pour serpentin de refroidissement G1/2"</p>		13	324	324	460	335	116	300	8
14	155	130	2825	2725	3005	2905			14	324	324	530	405	116	300	8
15	220	180	3990	3795	4245	4050			15	396	396	540	395	119	335	8
16	230	190	4345	4160	4615	4430			16	396	396	585	440	119	335	8
17	320	260	5620	5320	5940	5640			17	468	324	580	425	134	380	8
18	335	275	6150	5860	6520	6230			18	468	324	640	485	134	380	8

Kühlschlange geeignet für Süß-, See- und Brackwasser  
Cooling coil suitable for fresh, sea and brackish water  
Serpentin de refroidissement adapté à l'eau douce, de mer et saumâtre

x) Erforderliche Kühlwassermenge, max. Kühlwasserdruck: 8 bar  
Cooling water quantity required; max. cooling water pressure: 8 bar  
Quantité d'eau de refroidissement nécessaire

Abmessungen in mm

Dimensions in mm

Dimensions en mm

**1) Wellen:**

- n<sub>6</sub> > Ø 100
- Paßfedernut nach DIN 6885/1, Nabennutbreite nach ISO JS9
- Paßfeder nach DIN 6885/1 Form B
- Einzelheiten siehe Seiten 126 - 135

**1) Shafts:**

- n<sub>6</sub> > Ø 100
- Keyway acc. to DIN 6885/1, Hub keyway width acc. to ISO JS9
- Parallel key acc. to DIN 6885/1 form B
- For details, see pages 126 - 135

**1) Arbres:**

- n<sub>6</sub> > Ø 100
- Rainure de clavette selon DIN 6885/1, Tolérance dans le moyeu selon ISO JS9
- Clavette selon DIN 6885/1 forme B
- Détails voir pages 126 - 135

\*) Richtwerte; genaue Angaben nach auftragsbezogener Dokumentation.

\*) Approximate values; exact data acc. to order-related documentation.

\*) Valeurs approximatives; données exactes selon documentation relative à la commande.

\*\*) ohne Ölfüllung

\*\*) Without oil filling

\*\*) sans huile





# Zahnradgetriebe

Dreistufig  
Horizontal  
Bauart B3.H  
Größen 4 - 12

# Gear Units

Three Stage  
Horizontal  
Type B3.H  
Sizes 4 - 12

# Réducteurs à engrenages

à trois trains  
Horizontal  
Type B3.H  
Tailles 4 - 12

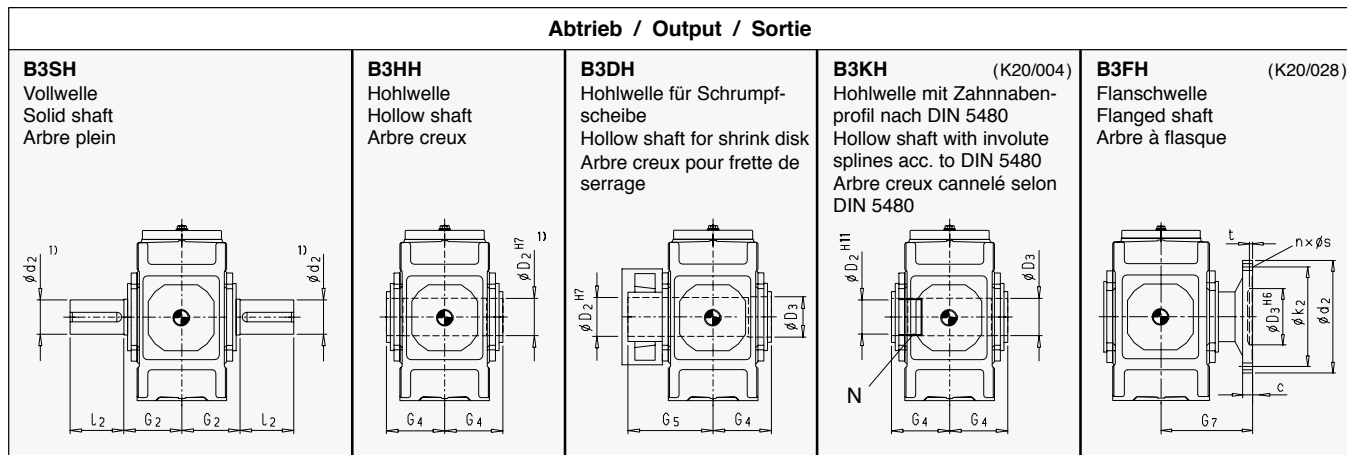

Größe Size Taille	B3SH			B3HH		B3DH				B3KH				B3FH									
	d <sub>2</sub>	l <sub>2</sub>	G <sub>2</sub>	D <sub>2</sub>	G <sub>4</sub>	D <sub>2</sub>	D <sub>3</sub>	G <sub>4</sub>	G <sub>5</sub>	N / DIN 5480				c	d <sub>2</sub>	D <sub>3</sub>	k <sub>2</sub>	n x s	t	G <sub>7</sub>			
4	80	170	140	80	140	85	85	140	205	-				-	-	-	-	-	-	-	-		
5	100	210	165	95	165	100	100	165	240	N 95x3x30x30x9H				89	100	165	25	300	150	260	16 x 22	10	255
6	110	210	165	105	165	110	110	165	240	N 95x3x30x30x9H				89	110	165	25	320	160	280	18 x 22	10	255
7	120	210	195	115	195	120	120	195	280	N 120x3x30x38x9H				114	120	195	30	370	180	320	16 x 26	10	300
8	130	250	195	125	195	130	130	195	285	N 120x3x30x38x9H				114	130	195	30	390	190	340	18 x 26	10	300
9	140	250	235	135	235	140	145	235	330	N 140x3x30x45x9H				134	145	235	38	430	220	380	20 x 26	12	350
10	160	300	235	150	235	150	155	235	350	N 140x3x30x45x9H				134	155	235	38	470	240	420	22 x 26	12	350
11	170	300	270	165	270	165	170	270	400	N 170x5x30x32x9H				160	170	270	42	510	260	450	18 x 33	12	400
12	180	300	270	180	270	180	185	270	405	N 170x5x30x32x9H				160	185	270	42	540	280	480	22 x 33	12	400

Größe Size Taille	Ölmenge Oil quantity Quantité de huile (l) *	Gewicht / Weight Poids (kg) ** **)	
		B3SH B3HH B3DH B3KH	B3FH
4	9	210	-
5	15	325	360
6	16	380	420
7	27	550	600
8	30	635	690
9	42	890	975
10	45	1020	1110
11	71	1455	1585
12	76	1730	1870

**Kühlschlange / Cooling coil  
Serpentin de refroidissement**

Abtrieb / Output / Sortie

Wasseranschluß für Kühlschlange G1/2"  
Water connection for cooling coil G1/2"  
Adduction pour serpentin de refroidissement G1/2"

Kühlschlange geeignet für Süß-, See- und Brackwasser  
Cooling coil suitable for fresh, sea and brackish water  
Serpentin de refroidissement adapté à l'eau douce, de mer et saumâtre

Größe Size Taille	b <sub>10</sub>	e <sub>10</sub>	h <sub>10</sub>	l/(min x)
4	34	155	60	4
5	68	170	64	4
6	70	220	69	4
7	100	210	83	4
8	100	270	83	4
9	140	245	110	8
10	100	295	95	8
11	110	275	95	8
12	200	360	109	8

x) Erforderliche Kühlwassermenge, max. Kühlwasserdruck: 8 bar / Cooling water quantity required; max. cooling water pressure: 8 bar / Quantité d'eau de refroidissement nécessaire, pression maxi de l'eau de refroidissement: 8 bar

Abmessungen in mm

Dimensions in mm

Dimensions en mm

**1) Wellen:**

- k<sub>6</sub> = Ø 25; Ø 28 ≥ m<sub>6</sub> ≤ Ø 100; n<sub>6</sub> > Ø 100
- Paßfedernut nach DIN 6885/1, Nabennutbreite nach ISO JS9
- Paßfeder nach DIN 6885/1 Form B
- Einzelheiten siehe Seiten 126 - 135

**1) Shafts:**

- k<sub>6</sub> = Ø 25; Ø 28 ≥ m<sub>6</sub> ≤ Ø 100; n<sub>6</sub> > Ø 100
- Keyway acc. to DIN 6885/1, Hub keyway width acc. to ISO JS9
- Parallel key acc. to DIN 6885/1 form B
- For details, see pages 126 - 135

**1) Arbres:**

- k<sub>6</sub> = Ø 25; Ø 28 ≥ m<sub>6</sub> ≤ Ø 100; n<sub>6</sub> > Ø 100
- Rainure de clavette selon DIN 6885/1, Tolérance dans le moyeu selon ISO JS9
- Clavette selon DIN 6885/1 forme B
- Détails voir pages 126 - 135

\*) Richtwerte; genaue Angaben nach auftragsbezogener Dokumentation.

\*) Approximate values; exact data acc. to order-related documentation.

\*) Valeurs approximatives; données exactes selon documentation relative à la commande.

\*\*) ohne Ölfüllung

\*\*) Without oil filling

\*\*) sans huile



# Zahnradgetriebe

Dreistufig  
Horizontal  
Bauarten B3.H, B3.M  
Größen 13 - 22

# Gear Units

Three Stage  
Horizontal  
Types B3.H, B3.M  
Sizes 13- 22

# Réducteurs à engrenages

à trois trains  
Horizontal  
Types B3.H, B3.M  
Tailles 13 - 22

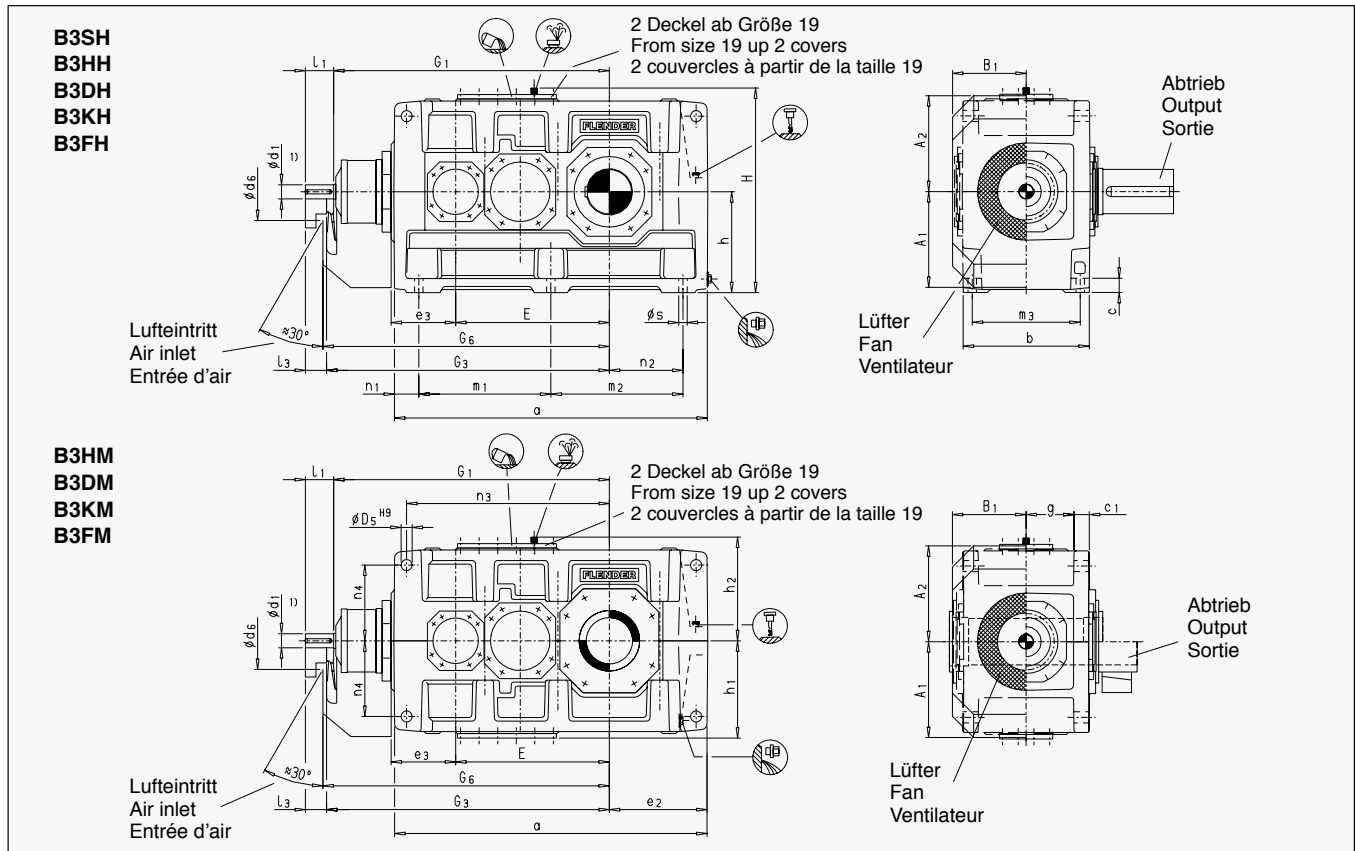

Größe Size Taille	Antrieb / Input / Entrée						Lüfter / Fan / Ventilateur							
	$i_N = 12.5 - 45$			$i_N = 50 - 71$			$G_1$	$G_3$	$G_1$	$G_3$	$A_1$	$A_2$	$B_1$	$d_6$
	$d_1$	$l_1$	$l_3$	$d_1$	$l_1$	$l_3$								
13 + 14	80	165	130	60	140	105	1125	1160	1195	1230	425	435	325	210
15 + 16	90	165	130	70	140	105	1367	1402	1413	1448	485	520	365	210
17 + 18	110	205	165	80	170	130	1560	1600	1620	1660	535	570	395	230
19 + 20	130	245	200	100	210	165	1832	1877	1892	1937	610	630	448	245
21 + 22	130	245	200	100	210	165	1902	1947	1957	2002	690	690	473	280

Größe Size Taille	Zahnradgetriebe / Gear units / Réducteurs à engrenages												
	b	c	$c_1$	$D_5$	$e_3$	g	$h_{-1}$	$h_1$	$h_2$	$m_3$	$n_1$	$n_4$	s
13 + 14	550	60	$61 \pm 2$	48	265	211.5	440	450	460	475	100	340	35
15 + 16	625	70	$72 \pm 2$	55	320	238	500	490	500	535	120	375	42
17 + 18	690	80	$81 \pm 2$	55	370	259	550	555	560	600	135	425	42
19 + 20	790	90	$91 \pm 2$	65	420	299	620	615	620	690	155	475	48
21 + 22	830	100	$100 \pm 2$	75	450	310	700	685	690	720	170	520	56

Größe Size Taille	Zahnradgetriebe / Gear units / Réducteurs à engrenages									Rücklaufsperre Backstop / Anti-dévireur $G_B^{+)}$
	a	$e_2$	E	$G_6$	H	$m_1$	$m_2$	$n_2$	$n_3$	
13	1290	405	635	1180	900	545	545	305	835	451
14	1430	475	705	1250	900	545	685	375	905	451
15	1550	485	762	1420	1000	655	655	365	1005	497
16	1640	530	808	1470	1000	655	745	410	1050	497
17	1740	525	860	1620	1110	735	735	390	1145	564
18	1860	585	920	1680	1110	735	855	450	1205	564
19	2010	590	997	1900	1240	850	850	435	1345	621
20	2130	650	1057	1960	1240	850	970	495	1405	621
21	2140	655	1067	1970	1390	900	900	485	1400	640
22	2250	710	1122	2025	1390	900	1010	540	1455	640

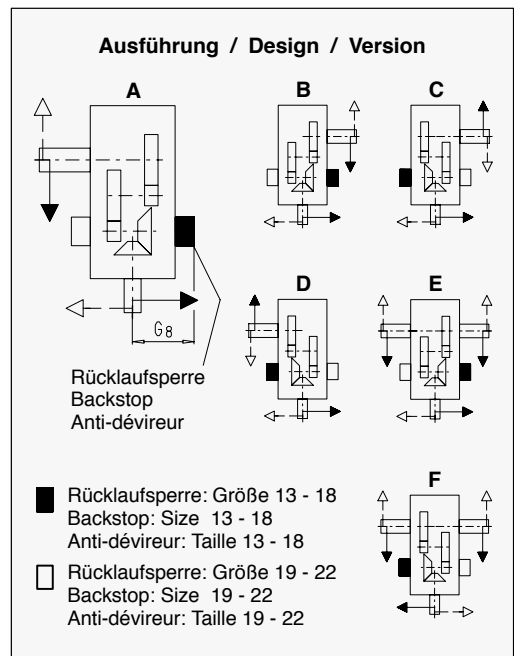

+) max. Abmessungen; Einzelheiten nach auftragsbezogener Dokumentation.

+) Max. dimensions; details acc. to order-related documentation.

+) Dimensions maximales; détails selon documentation relative à la commande.



# Zahnradgetriebe

Dreistufig  
Horizontal  
Bauarten B3.H, B3.M  
Größen 13 - 22

# Gear Units

Three Stage  
Horizontal  
Types B3.H, B3.M  
Sizes 13 - 22

# Réducteurs à engrenages

à trois trains  
Horizontal  
Types B3.H, B3.M  
Tailles 13 - 22

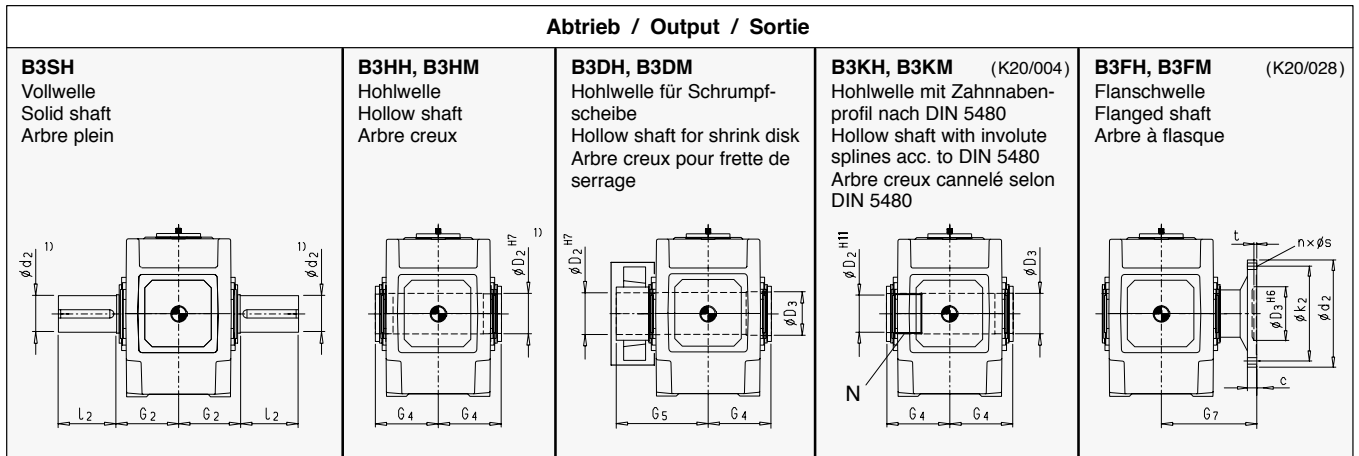

Größe Size Taille	B3SH			B3HH, B3HM		B3DH, B3DM				B3KH, B3KM				B3FH, B3FM									
	d <sub>2</sub>	l <sub>2</sub>	G <sub>2</sub>	D <sub>2</sub>	G <sub>4</sub>	D <sub>2</sub>	D <sub>3</sub>	G <sub>4</sub>	G <sub>5</sub>	N / DIN 5480				c	d <sub>2</sub>	D <sub>3</sub>	k <sub>2</sub>	n x s	t	G <sub>7</sub>			
13	200	350	335	190	335	190	195	335	480	N 190x5x30x36x9H				180	195	335	48	580	310	500	20 x 33	14	480
14	210	350	335	210	335	210	215	335	480	N 190x5x30x36x9H				180	215	335	48	620	310	540	24 x 33	14	480
15	230	410	380	230	380	230	235	380	550	N 220x5x30x42x9H				210	235	380	55	710	360	630	28 x 33	17	550
16	240	410	380	240	380	240	245	380	550	N 220x5x30x42x9H				210	245	380	55	740	360	660	30 x 33	17	550
17	250	410	415	250	415	250	260	415	600	N 250x5x30x48x9H				240	260	415	60	750	410	660	24 x 39	18	600
18	270	470	415	275	415	280	285	415	600	N 250x5x30x48x9H				240	285	415	60	800	410	710	26 x 39	18	600
19	290	470	465	-	-	285	295	465	670	Auf Anfrage On request Sur demande				65	860	460	770	30 x 39	18	670			
20	300	500	465	-	-	310	315	465	670					65	930	460	830	32 x 39	18	670			
21	320	500	490	-	-	330	335	490	715					75	950	520	850	28 x 45	20	710			
22	340	550	490	-	-	340	345	490	725					75	1040	520	940	28 x 45	20	710			

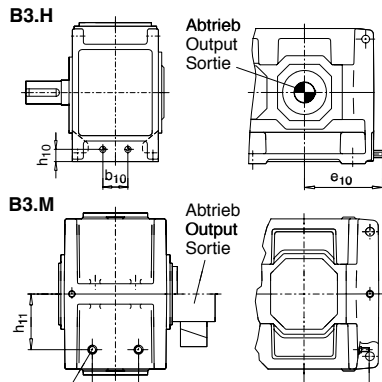
Größe Size Taille	Ölmenge / Oil quantity / Quantité de huile (l) *)		Gewicht / Weight / Poids (kg) **)				Kühlschlange / Cooling coil / Serpentin de refroidissement		Größe / Size / Taille					
	B3.H	B3.M	B3SH B3HH B3DH B3KH	B3HM B3KM B3DM	B3FH	B3FM			b <sub>10</sub>	e <sub>10</sub>	e <sub>11</sub>	h <sub>10</sub>	h <sub>11</sub>	l/(min x)
13	130	110	2380	2260	2540	2420	 <p>Abtrieb Output / Sortie</p> <p>Wasseranschluß für Kühlschlange G1/2" Water connection for cooling coil G1/2" Adduction pour serpentin de refroidissement G1/2"</p> <p>x) Erforderliche Kühlwassermenge, max. Kühlwasserdruck: 8 bar / Cooling water quantity required; max. cooling water pressure: 8 bar / Quantité d'eau de refroidissement nécessaire, pression maxi de l'eau de refroidissement: 8 bar</p>		252	455	335	116	300	8
14	140	115	2750	2615	2920	2785			252	525	405	116	300	8
15	210	160	3730	3540	3970	3780			290	535	395	119	335	8
16	220	165	3955	3765	4250	4020			290	580	440	119	335	8
17	290	230	4990	4760	5290	5060			340	575	425	134	380	8
18	300	235	5495	5240	6045	5590			340	635	485	134	380	8
19	380	360	7000	6500	Auf Anfrage On request Sur demande				Auf Anfrage On request Sur demande					
20	440	420	8100	7600										
21	370	420	9200	8600										
22	430	490	9900	9400										

Abmessungen in mm

**1) Wellen:**

- m<sub>6</sub> ≤ ∅ 100; n<sub>6</sub> > ∅ 100
- Paßfedern nach DIN 6885/1, Nabennutbreite nach ISO JS9
- Paßfeder nach DIN 6885/1 Form B
- Einzelheiten siehe Seiten 126 - 135

\*) Richtwerte; genaue Angaben nach auftragsbezogener Dokumentation.

\*\*) ohne Ölfüllung

Dimensions in mm

**1) Shafts:**

- m<sub>6</sub> ≤ ∅ 100; n<sub>6</sub> > ∅ 100
- Keyway acc. to DIN 6885/1, Hub keyway width acc. to ISO JS9
- Parallel key acc. to DIN 6885/1 form B
- For details, see pages 126 - 135

\*) Approximate values; exact data acc. to order-related documentation.

\*\*) Without oil filling

Dimensions en mm

**1) Arbres:**

- m<sub>6</sub> ≤ ∅ 100; n<sub>6</sub> > ∅ 100
- Rainure de clavette selon DIN 6885/1, Tolérance dans le moyeu selon ISO JS9
- Clavette selon DIN 6885/1 forme B
- Détails voir pages 126 - 135

\*) Valeurs approximatives; données exactes selon documentation relative à la commande.

\*\*) sans huile



# Zahnradgetriebe

Dreistufig  
Horizontal  
Bauarten B3.H, B3DM  
Größen 23 - 26

# Gear Units

Three Stage  
Horizontal  
Types B3.H, B3DM  
Sizes 23- 26

# Réducteurs à engrenages

à trois trains  
Horizontal  
Types B3.H, B3DM  
Tailles 23 - 26

**B3SH  
B3DH**

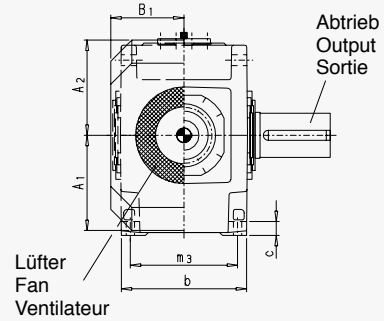
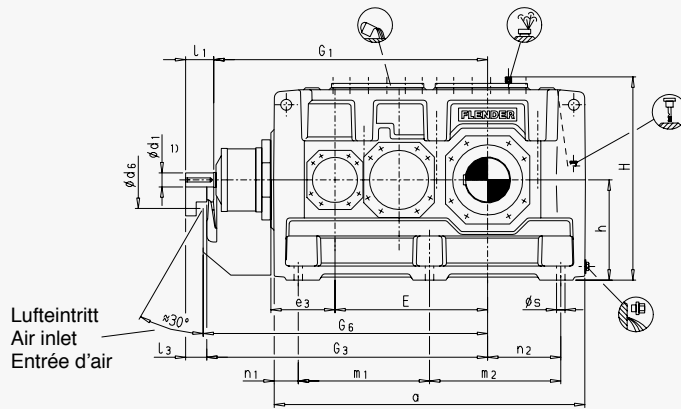

**B3DM**

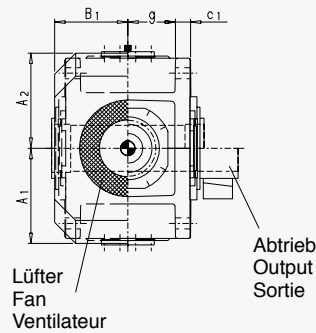
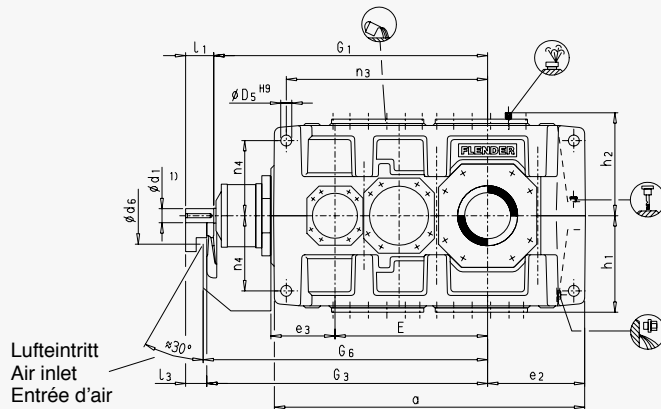

4

Größe Size Taille	Antrieb / Input / Entrée						Lüfter / Fan / Ventilateur								
	$i_N = 20 - 45$			$i_N = 50 - 71$			$G_1$	$G_3$	$G_1$	$G_3$	$A_1$	$A_2$	$B_1$	$d_6$	
	$d_1$	$l_1$	$l_3$	$d_1$	$l_1$	$l_3$									
<b>23 + 24</b>	150	245	200	110	210	165	2130	2175	2195	2240	770	770	528	350	
<b>25 + 26</b>	150	245	200	110	210	165	2270	2315	2360	2405	845	865	585	380	

Größe Size Taille	Zahnradgetriebe / Gear units / Réducteurs à engrenages												
	b	c	$c_1$	$D_5$	$e_3$	g	$h_{-1}$	$h_1$	$h_2$	$m_3$	$n_1$	$n_4$	s
<b>23 + 24</b>	930	115	$120 \pm 2$	80	490	342	780	770	790	810	180	580	56
<b>25 + 26</b>	1045	130	$120 \pm 2$	90	490	400	860	860	860	910	200	660	66

Größe Size Taille	Zahnradgetriebe / Gear units / Réducteurs à engrenages									Rücklauf- sperre Backstop Antidévireur $G_8$
	a	$e_2$	E	$G_6$	H	$m_1$	$m_2$	$n_2$	$n_3$	
<b>23</b>	2380	730	1185	2200	1570	1010	1010	550	1560	Maße auf Anfrage Dimensions on request Dimensions sur demande
<b>24</b>	2510	795	1250	2265	1570	1010	1140	615	1625	
<b>25</b>	2580	790	1325	2315	1720	1090	1090	590	1685	
<b>26</b>	2760	880	1415	2430	1720	1090	1270	680	1775	

## Ausführung / Design / Version

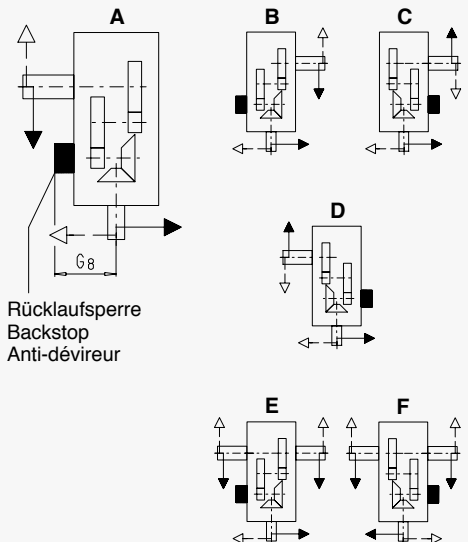

# Zahnradgetriebe

Dreistufig  
Horizontal  
Bauarten B3.H, B3DM  
Größen 23 - 26

# Gear Units

Three Stage  
Horizontal  
Types B3.H, B3DM  
Sizes 23 - 26

# Réducteurs à engrenages

à trois trains  
Horizontal  
Types B3.H, B3DM  
Tailles 23 - 26

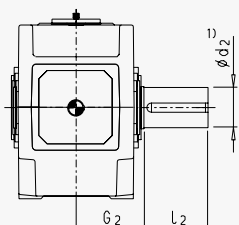
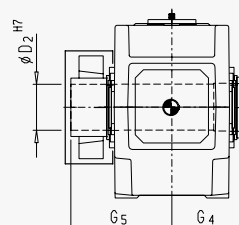
Abtrieb / Output / Sortie		
<b>B3SH</b> Vollwelle Solid shaft Arbre plein  	<b>B3DH, H3DM</b> Hohlwelle für Schrumpfscheibe Hollow shaft for shrink disk Arbre creux pour frette de serrage  	

Größe Size Taille	B3SH			B3DH, B3DM			
	d <sub>2</sub>	l <sub>2</sub>	G <sub>2</sub>	D <sub>2</sub>	D <sub>3</sub>	G <sub>4</sub>	G <sub>5</sub>
23	360	590	540	360	365	540	785
24	380	590	540	380	385	540	805
25	400	650	605	400	405	605	875
26	420	650	605	430	435	605	900

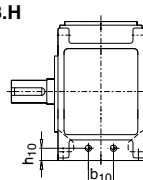
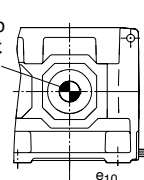
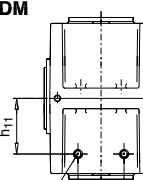
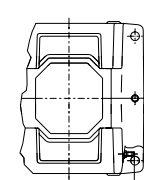
Größe Size Taille	Ölmenge Oil quantity Quantité de huile (l) *)		Gewicht Weight / Poids (kg) **) **)		Kühlschlange / Cooling coil Serpentin de refroidissement									
	B3SH	B3DM	B3SH B3DH	B3DM	B3.H	Abtrieb Output Sortie		Größe Size Taille	b <sub>10</sub>	e <sub>10</sub>	e <sub>11</sub>	h <sub>10</sub>	h <sub>11</sub>	l/(min x)
23	520	560	11500	10600			Auf Anfrage On request Sur demande	23						
24	600	650	13400	12500				24						
25	720	790	16000	15100				25						
26	840	920	17500	16400				26						

Wasseranschluß für Kühlschlange G1/2"  
Water connection for cooling coil G1/2"  
Adduction pour serpentin de refroidissement G1/2"

Kühlschlange geeignet für Süß-, See- und Brackwasser  
Cooling coil suitable for fresh, sea and brackish water  
Serpentin de refroidissement adapté à l'eau douce, de mer et saumâtre

x) Erforderliche Kühlwassermenge, max. Kühlwasserdruck: 8 bar  
Cooling water quantity required; max. cooling water pressure: 8 bar  
Quantité d'eau de refroidissement nécessaire, pression maxi de l'eau de refroidissement: 8 bar

Abmessungen in mm

1) **Wellen:**

- n<sub>6</sub> > Ø 100
- Paßfedernut nach DIN 6885/1, Nabennutbreite nach ISO JS9
- Paßfeder nach DIN 6885/1 Form B
- Einzelheiten siehe Seiten 126 - 135

\*) Richtwerte; genaue Angaben nach auftragsbezogener Dokumentation.

\*\*) ohne Ölfüllung

Dimensions in mm

1) **Shafts:**

- n<sub>6</sub> > Ø 100
- Keyway acc. to DIN 6885/1, Hub keyway width acc. to ISO JS9
- Parallel key acc. to DIN 6885/1 form B
- For details, see pages 126 - 135

\*) Approximate values; exact data acc. to order-related documentation.

\*\*) Without oil filling

Dimensions en mm

1) **Arbres:**

- n<sub>6</sub> > Ø 100
- Rainure de clavette selon DIN 6885/1, Tolérance dans le moyeu selon ISO JS9
- Clavette selon DIN 6885/1 forme B
- Détails voir pages 126 - 135

\*) Valeurs approximatives; données exactes selon documentation relative à la commande.

\*\*) sans huile



# Zahnradgetriebe

Vierstufig  
Horizontal  
Bauart B4.H  
Größen 5 - 12

# Gear Units

Four Stage  
Horizontal  
Type B4.H  
Sizes 5 - 12

# Réducteurs à engrenages

à quatre trains  
Horizontal  
Type B4.H  
Tailles 5 - 12

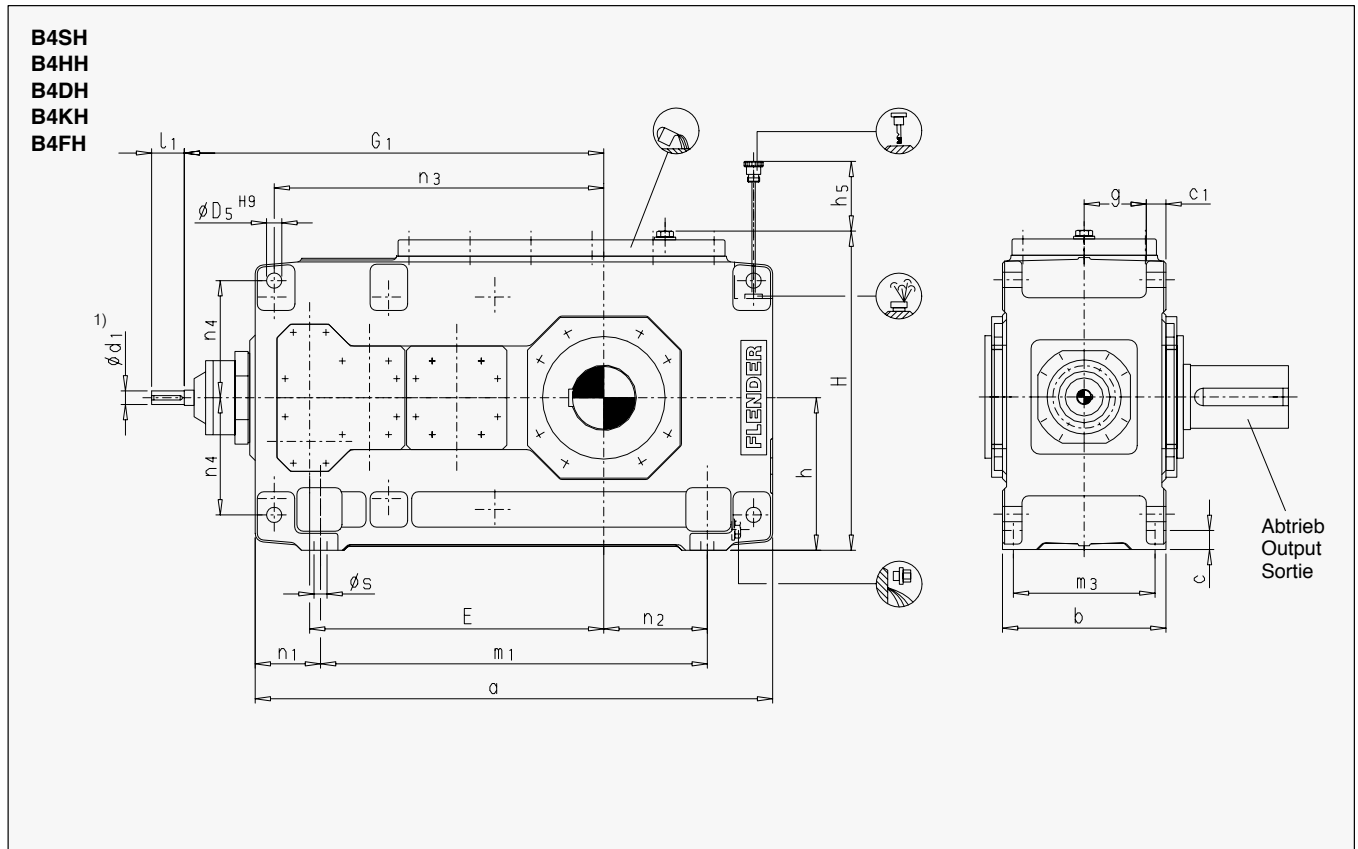

4

Größe Size Taille	Antrieb / Input / Entrée					
	$i_N = 80 - 180$		$i_N = 200 - 315$		$G_1$	$G_1$
	$d_1$	$l_1$	$d_1$	$l_1$		
5 + 6	28	55	20	50	615	650
7 + 8	30	70	25	60	725	770
9 + 10	35	80	28	60	840	890
11 + 12	45	100	35	80	1010	1080

Größe Size Taille	Zahnradgetriebe / Gear units / Réducteurs à engrenages									
	b	c	$c_1$	$D_5$	g	$h_{-1}$	$m_3$	$n_1$	$n_4$	s
5 + 6	255	28	$30 \pm 1$	24	97.5	230	220	105	180	19
7 + 8	300	35	$36 \pm 1$	28	114	280	260	120	215	24
9 + 10	370	40	$45 \pm 1.5$	36	140	320	320	145	245	28
11 + 12	430	50	$54 \pm 1.5$	40	161	380	370	165	300	35

Größe Size Taille	Zahnradgetriebe / Gear units / Réducteurs à engrenages							
	a	E	$h_5$	H	$m_1$	$n_2$	$n_3$	Rücklaufsperr- Backstop / Anti- dévireur $G_8^{+}$
5	690	405	100	482	480	100	455	236
6	770	440	100	482	560	145	490	236
7	845	495	140	572	605	130	560	286
8	950	540	130	582	710	190	605	286
9	1000	580	135	662	710	155	660	317
10	1100	630	135	662	810	205	710	317
11	1200	705	170	782	870	180	805	333
12	1355	775	160	790	1025	265	875	333

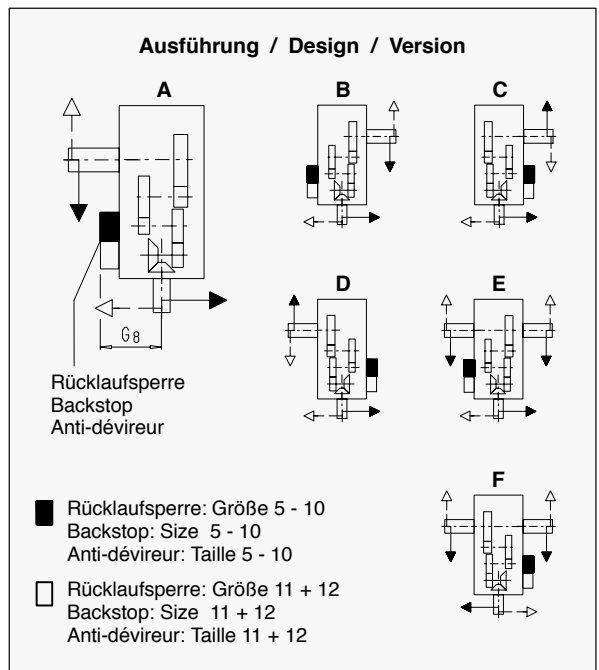

+) max. Abmessungen; Einzelheiten nach auftragsbezogener Dokumentation.

+) Max. dimensions; details acc. to order-related documentation.

+) Dimensions maximales; détails selon documentation relative à la commande.

# Zahnradgetriebe

Vierstufig  
Horizontal  
Bauart B4.H  
Größen 5 - 12

# Gear Units

Four Stage  
Horizontal  
Type B4.H  
Sizes 5 - 12

# Réducteurs à engrenages

à quatre trains  
Horizontal  
Type B4.H  
Tailles 5 - 12

## Abtrieb / Output / Sortie

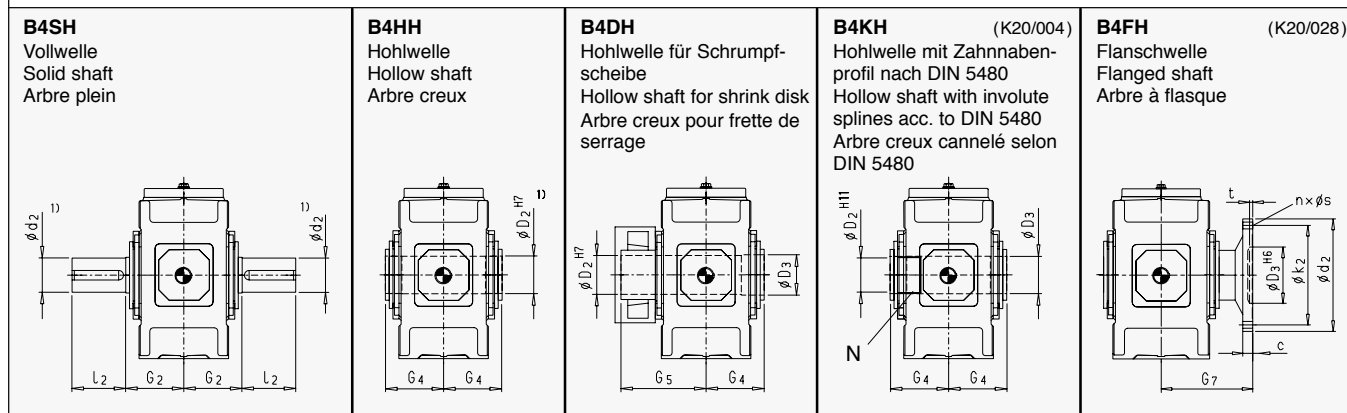

Größe Size Taille	B4SH			B4HH		B4DH				B4KH				B4FH							
	d <sub>2</sub>	l <sub>2</sub>	G <sub>2</sub>	D <sub>2</sub>	G <sub>4</sub>	D <sub>2</sub>	D <sub>3</sub>	G <sub>4</sub>	G <sub>5</sub>	N / DIN 5480		D <sub>2</sub>	D <sub>3</sub>	G <sub>4</sub>	c	d <sub>2</sub>	D <sub>3</sub>	k <sub>2</sub>	n x s	t	G <sub>7</sub>
5	100	210	165	95	165	100	100	165	240	N 95x3x30x30x9H		89	100	165	25	300	150	260	16 x 22	10	255
6	110	210	165	105	165	110	110	165	240	N 95x3x30x30x9H		89	110	165	25	320	160	280	18 x 22	10	255
7	120	210	195	115	195	120	120	195	280	N 120x3x30x38x9H		114	120	195	30	370	180	320	16 x 26	10	300
8	130	250	195	125	195	130	130	195	285	N 120x3x30x38x9H		114	130	195	30	390	190	340	18 x 26	10	300
9	140	250	235	135	235	140	145	235	330	N 140x3x30x45x9H		134	145	235	38	430	220	380	20 x 26	12	350
10	160	300	235	150	235	150	155	235	350	N 140x3x30x45x9H		134	155	235	38	470	240	420	22 x 26	12	350
11	170	300	270	165	270	165	170	270	400	N 170x5x30x32x9H		160	170	270	42	510	260	450	18 x 33	12	400
12	180	300	270	180	270	180	185	270	405	N 170x5x30x32x9H		160	185	270	42	540	280	480	22 x 33	12	400

Größe Size Taille	Ölmenge Oil quantity Quantité de huile (l) *)	Gewicht Weight / Poids (kg) **) **)	
		B4SH B4HH B4DH B4KH	B4FH
5	16	335	370
6	18	385	425
7	30	555	605
8	33	655	710
9	48	890	975
10	50	1025	1115
11	80	1485	1615
12	90	1750	1890

Abmessungen in mm

### 1) Wellen:

- $k_6 \leq \varnothing 25$ ;  $\varnothing 28 \geq m_6 \leq \varnothing 100$ ;  $n_6 > \varnothing 100$
- Paßfedernut nach DIN 6885/1, Nabennutbreite nach ISO JS9
- Paßfeder nach DIN 6885/1 Form B
- Einzelheiten siehe Seiten 126 - 135

\*) Richtwerte; genaue Angaben nach auftragsbezogener Dokumentation.

\*\*) ohne Ölfüllung

Dimensions in mm

### 1) Shafts:

- $k_6 \leq \varnothing 25$ ;  $\varnothing 28 \geq m_6 \leq \varnothing 100$ ;  $n_6 > \varnothing 100$
- Keyway acc. to DIN 6885/1, Hub keyway width acc. to ISO JS9
- Parallel key acc. to DIN 6885/1 form B
- For details, see pages 126 - 135

\*) Approximate values; exact data acc. to order-related documentation.

\*\*) Without oil filling

Dimensions en mm

### 1) Arbres:

- $k_6 \leq \varnothing 25$ ;  $\varnothing 28 \geq m_6 \leq \varnothing 100$ ;  $n_6 > \varnothing 100$
- Rainure de clavette selon DIN 6885/1, Tolérance dans le moyeu selon ISO JS9
- Clavette selon DIN 6885/1 forme B
- Détails voir pages 126 - 135

\*) Valeurs approximatives; données exactes selon documentation relative à la commande.

\*\*) sans huile

# Zahnradgetriebe

Vierstufig  
Horizontal  
Bauarten B4.H, B4.M  
Größen 13 - 22

# Gear Units

Four Stage  
Horizontal  
Types B4.H, B4.M  
Sizes 13 - 22

# Réducteurs à engrenages

à quatre trains  
Horizontal  
Types B4.H, B4.M  
Tailles 13 - 22

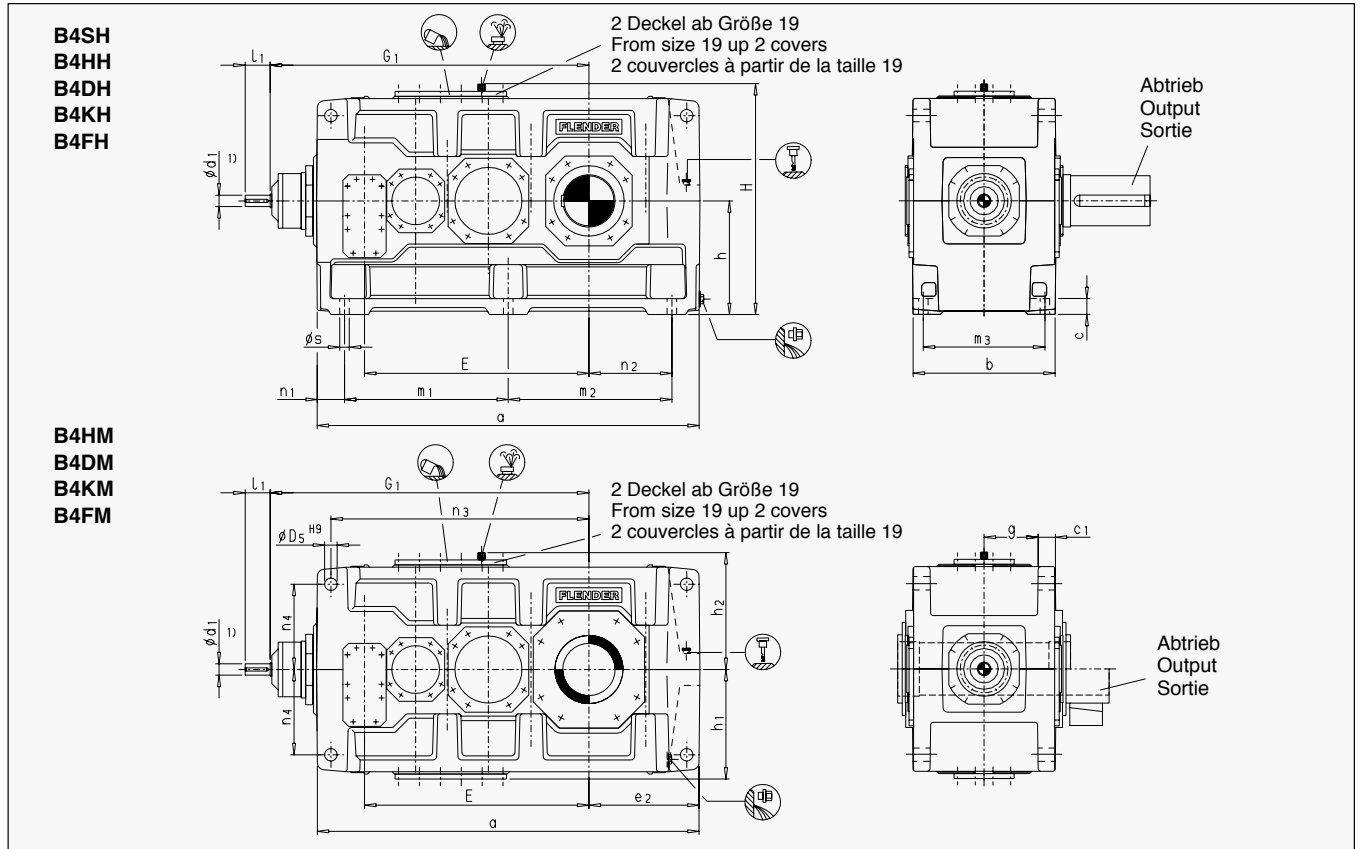

Größe Size Taille	Antrieb / Input / Entrée					
	$i_N = 80 - 180$		$i_N = 200 - 315$		$G_1$	$G_1$
	$d_1$	$l_1$	$d_1$	$l_1$		
13 + 14	55	110	40	100	1170	1240
15 + 16	70	135	50	110	1402	1448
17 + 18	70	135	50	110	1450	1510
19 + 20	80	165	60	140	1680	1740
21 + 22	90	165	70	140	1992	2047

Größe Size Taille	Zahnradgetriebe / Gear units / Réducteurs à engrenages											
	b	c	$c_1$	$D_5$	g	$h_{-1}$	$h_1$	$h_2$	$m_3$	$n_1$	$n_4$	s
13 + 14	550	60	$61 \pm 2$	48	211.5	440	450	460	475	100	340	35
15 + 16	625	70	$72 \pm 2$	55	238	500	490	500	535	120	375	42
17 + 18	690	80	$81 \pm 2$	55	259	550	555	560	600	135	425	42
19 + 20	790	90	$91 \pm 2$	65	299	620	615	620	690	155	475	48
21 + 22	830	100	$100 \pm 2$	75	310	700	685	690	720	170	520	56

Größe Size Taille	Zahnradgetriebe / Gear units / Réducteurs à engrenages									
	a	$e_2$	E	H	$m_1$	$m_2$	$n_2$	$n_3$	Rücklaufsperre Backstop / Anti-déviereur $G_8^{+}$	
13	1395	405	820	900	597.5	597.5	305	940	391	
14	1535	475	890	900	597.5	737.5	375	1010	391	
15	1680	485	987	1000	720	720	365	1135	487	
16	1770	530	1033	1000	720	810	410	1180	487	
17	1770	525	1035	1110	750	750	390	1175	487	
18	1890	585	1095	1110	750	870	450	1235	487	
19	2030	590	1190	1240	860	860	435	1365	561	
20	2150	650	1250	1240	860	980	495	1425	561	
21	2340	655	1387	1390	1000	1000	485	1600	580	
22	2450	710	1442	1390	1000	1110	540	1655	580	

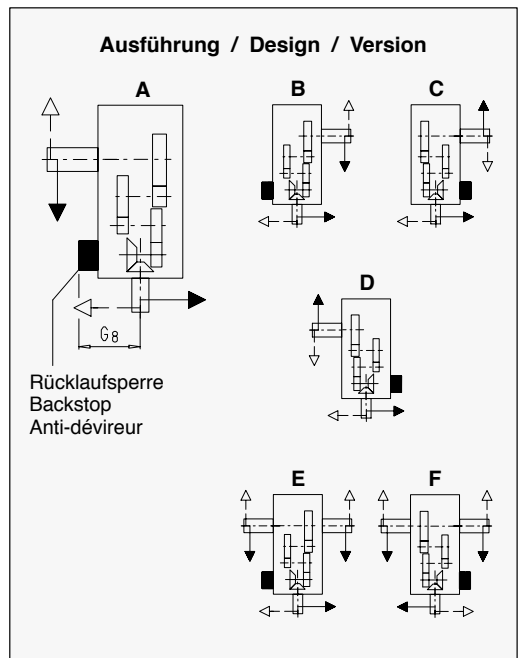

+) max. Abmessungen; Einzelheiten nach auftragsbezogener Dokumentation.

+) Max. dimensions; details acc. to order-related documentation.

+) Dimensions maximales; détails selon documentation relative à la commande.

# Zahnradgetriebe

Vierstufig  
Horizontal  
Bauarten B4.H, B4.M  
Größen 13 - 22

# Gear Units

Four Stage  
Horizontal  
Types B4.H, B4.M  
Sizes 13 - 22

# Réducteurs à engrenages

à quatre trains  
Horizontal  
Types B4.H, B4.M  
Tailles 13 - 22

## Abtrieb / Output / Sortie

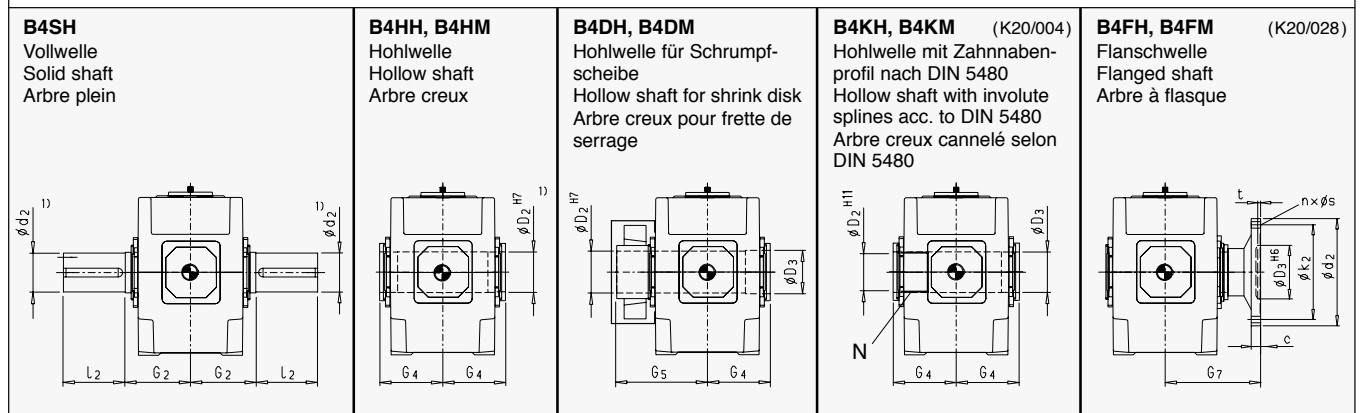

Größe Size Taille	B4SH			B4HH, B4HM		B4DH, B4DM				B4KH, B4KM				B4FH, B4FM								
	d <sub>2</sub>	l <sub>2</sub>	G <sub>2</sub>	D <sub>2</sub>	G <sub>4</sub>	D <sub>2</sub>	D <sub>3</sub>	G <sub>4</sub>	G <sub>5</sub>	N / DIN 5480			D <sub>2</sub>	D <sub>3</sub>	G <sub>4</sub>	c	d <sub>2</sub>	D <sub>3</sub>	k <sub>2</sub>	n x s	t	G <sub>7</sub>
13	200	350	335	190	335	190	195	335	480	N 190x5x30x36x9H			180	195	335	48	580	310	500	20 x 33	14	480
14	210	350	335	210	335	210	215	335	480	N 190x5x30x36x9H			180	215	335	48	620	310	540	24 x 33	14	480
15	230	410	380	230	380	230	235	380	550	N 220x5x30x42x9H			210	235	380	55	710	360	630	28 x 33	17	550
16	240	410	380	240	380	240	245	380	550	N 220x5x30x42x9H			210	245	380	55	740	360	660	30 x 33	17	550
17	250	410	415	250	415	250	260	415	600	N 250x5x30x48x9H			240	260	415	60	750	410	660	24 x 39	18	600
18	270	470	415	275	415	280	285	415	600	N 250x5x30x48x9H			240	285	415	60	800	410	710	26 x 39	18	600
19	290	470	465	-	-	285	295	465	670	Auf Anfrage On request Sur demande						65	860	460	770	30 x 39	18	670
20	300	500	465	-	-	310	315	465	670							65	930	460	830	32 x 39	18	670
21	320	500	490	-	-	330	335	490	715							75	950	520	850	28 x 45	20	710
22	340	550	490	-	-	340	345	490	725							75	1040	520	940	28 x 45	20	710

Größe Size Taille	Ölmenge Oil quantity Quantité de huile (l) *)		Gewicht Weight / Poids (kg) *) **)			
	B4.H	B4.M	B4SH B4HH B4DH B4KH	B4HM B4KM B4DM	B4FH	B4FM
13	145	120	2395	2280	2555	2440
14	150	125	2735	2605	2905	2775
15	230	170	3630	3435	3870	3675
16	235	175	3985	3765	4240	4020
17	295	230	4695	4460	4995	4760
18	305	235	5200	4930	5550	5280
19	480	440	6800	6300	Auf Anfrage On request Sur demande	
20	550	510	8200	7700		
21	540	590	9200	8600		
22	620	680	9900	9400		

Abmessungen in mm

### 1) Wellen:

- $m_6 \leq \varnothing 100$ ;  $n_6 > \varnothing 100$
- Paßfedernut nach DIN 6885/1, Nabennutbreite nach ISO JS9
- Paßfeder nach DIN 6885/1 Form B
- Einzelheiten siehe Seiten 126 - 135

\*) Richtwerte; genaue Angaben nach auftragsbezogener Dokumentation.

\*\*) ohne Ölfüllung

Dimensions in mm

### 1) Shafts:

- $m_6 \leq \varnothing 100$ ;  $n_6 > \varnothing 100$
- Keyway acc. to DIN 6885/1, Hub keyway width acc. to ISO JS9
- Parallel key acc. to DIN 6885/1 form B
- For details, see pages 126 - 135

\*) Approximate values; exact data acc. to order-related documentation.

\*\*) Without oil filling

Dimensions en mm

### 1) Arbres:

- $m_6 \leq \varnothing 100$ ;  $n_6 > \varnothing 100$
- Rainure de clavette selon DIN 6885/1, Tolérance dans le moyeu selon ISO JS9
- Clavette selon DIN 6885/1 forme B
- Détails voir pages 126 - 135

\*) Valeurs approximatives; données exactes selon documentation relative à la commande.

\*\*) sans huile

# Zahnradgetriebe

Vierstufig  
Horizontal  
Bauarten B4.H, B4DM  
Größen 23 - 26

# Gear Units

Four Stage  
Horizontal  
Types B4.H, B4DM  
Sizes 23 - 26

# Réducteurs à engrenages

à quatre trains  
Horizontal  
Types B4.H, B4DM  
Tailles 23 - 26

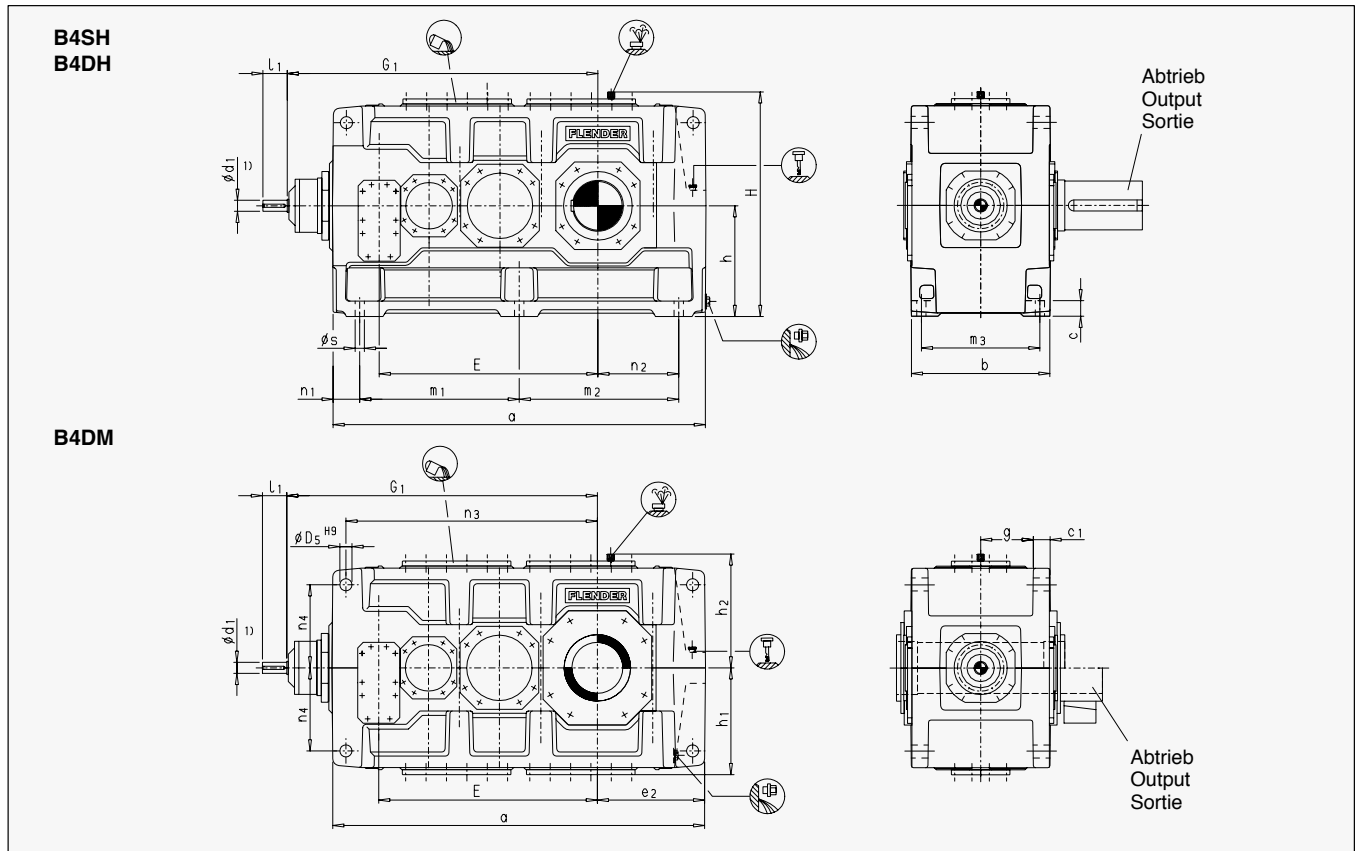

Größe Size Taille	Antrieb / Input / Entrée					
	$i_N = 80 - 180$		$i_N = 200 - 315$		$G_1$	$G_1$
	$d_1$	$l_1$	$d_1$	$l_1$		
23 + 24	90	165	70	140	2110	2175
25 + 26	110	205	80	170	2395	2485

Größe Size Taille	Zahnradgetriebe / Gear units / Réducteurs à engrenages											
	b	c	$c_1$	$D_5$	g	$h_{-1}$	$h_1$	$h_2$	$m_3$	$n_1$	$n_4$	s
23 + 24	930	115	$120 \pm 2$	80	342	780	770	790	810	180	580	56
25 + 26	1045	130	$120 \pm 2$	90	400	860	860	860	910	200	660	66

Größe Size Taille	Zahnradgetriebe / Gear units / Réducteurs à engrenages								Rücklauf- sperre Backstop Antidévireur $G_8$
	a	$e_2$	E	H	$m_1$	$m_2$	$n_2$	$n_3$	
23	2530	730	1505	1570	1085	1085	550	1725	Maße auf Anfrage Dimensions on request Dimensions sur demande
24	2660	795	1570	1570	1085	1215	615	1790	
25	2830	790	1695	1720	1215	1215	590	1965	
26	3010	880	1785	1720	1215	1395	680	2055	

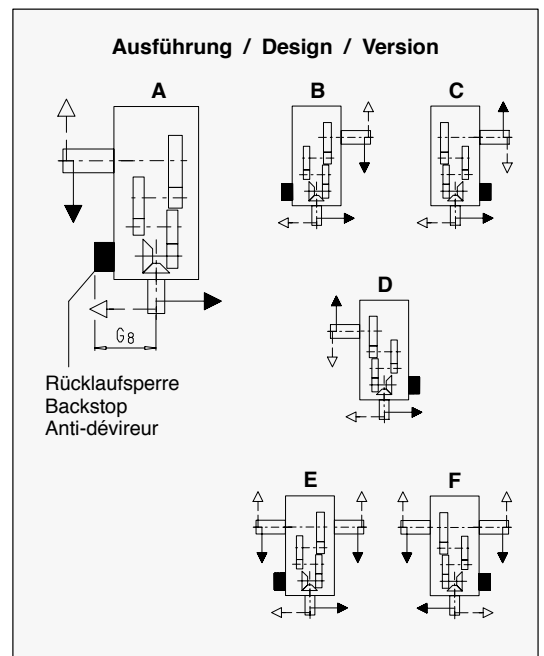



## Zahnradgetriebe

Vierstufig  
Horizontal  
Bauarten B4.H, B4DM  
Größen 23 - 26

## Gear Units

Four Stage  
Horizontal  
Types B4.H, B4DM  
Sizes 23 - 26

## Réducteurs à engrenages

à quatre trains  
Horizontal  
Types B4.H, B4DM  
Tailles 23 - 26

### Abtrieb / Output / Sortie

#### B4SH

Vollwelle  
Solid shaft  
Arbre plein

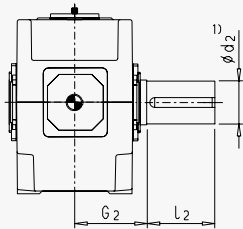

#### B4DH, B4DM

Hohlwelle für Schrumpfscheibe  
Hollow shaft for shrink disk  
Arbre creux pour frette de serrage

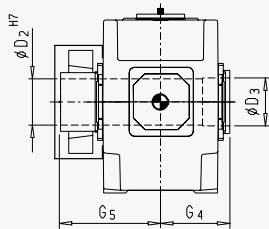

Größe Size Taille	B4SH			B4DH, B4DM			
	$d_2$	$l_2$	$G_2$	$D_2$	$D_3$	$G_4$	$G_5$
23	360	590	540	360	365	540	785
24	380	590	540	380	385	540	805
25	400	650	605	400	405	605	875
26	420	650	605	430	435	605	900

Größe Size Taille	Ölmenge Oil quantity Quantité de huile (l) *)		Gewicht Weight / Poids (kg) *) **)	
	B4SH	B4DM	B4SH B4DH	B4DM
23	710	790	11600	10700
24	810	910	13500	12600
25	1000	1110	16100	15200
26	1100	1200	17600	16500

Abmessungen in mm

#### 1) Wellen:

- $m_6 \leq \phi 100$ ;  $n_6 > \phi 100$
- Paßfedernut nach DIN 6885/1, Nabennutbreite nach ISO JS9
- Paßfeder nach DIN 6885/1 Form B
- Einzelheiten siehe Seiten 126 - 135

\*) Richtwerte; genaue Angaben nach auftragsbezogener Dokumentation.

\*\*\*) ohne Öfüllung

Dimensions in mm

#### 1) Shafts:

- $m_6 \leq \phi 100$ ;  $n_6 > \phi 100$
- Keyway acc. to DIN 6885/1, Hub keyway width acc. to ISO JS9
- Parallel key acc. to DIN 6885/1 form B
- For details, see pages 126 - 135

\*) Approximate values; exact data acc. to order-related documentation.

\*\*\*) Without oil filling

Dimensions en mm

#### 1) Arbres:

- $m_6 \leq \phi 100$ ;  $n_6 > \phi 100$
- Rainure de clavette selon DIN 6885/1, Tolérance dans le moyeu selon ISO JS9
- Clavette selon DIN 6885/1 forme B
- Détails voir pages 126 - 135

\*) Valeurs approximatives; données exactes selon documentation relative à la commande.

\*\*\*) sans huile

# Zahnradgetriebe

Zweistufig  
Vertikal  
Bauart H2.V  
Größen 4 - 12

# Gear Units

Two Stage  
Vertical  
Type H2.V  
Sizes 4 - 12

# Réducteurs à engrenages

à deux trains  
Vertical  
Type H2.V  
Tailles 4 - 12

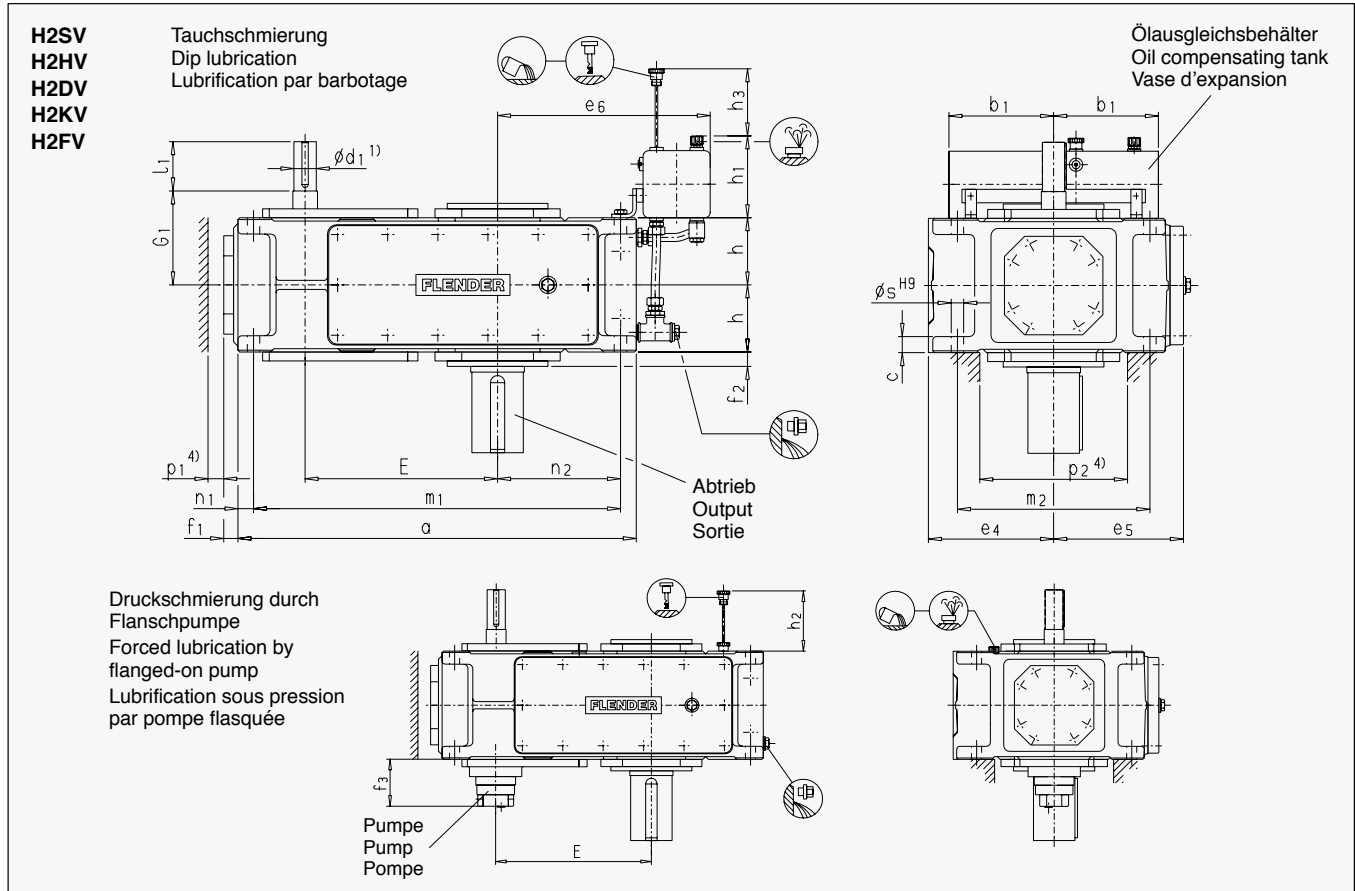

Größe Size Taille	Antrieb / Input / Entrée							Ausführung / Design / Version <sup>2)</sup>	
	$i_N = 6.3 - 11.2$			$i_N = 12.5 - 22.4$			$G_1$	G, H, I nur für / only for seulement pour $i_N =$	
	$d_1$	$l_1$	$l_3$	$d_1$	$l_1$	$l_3$			
4	45	100	80	32	80	60	170	6.3 - 18	
5 + 6	50	100	80	38	80	60	195	6.3 - 18	8 - 22.4
7 + 8	60	135	105	50	110	80	210	6.3 - 16	8 - 20
9 + 10	75	140	110	60	140	110	240	6.3 - 16	8 - 20
11 + 12	90	165	130	70	140	105	275	6.3 - 18	8 - 22.4

Größe Size Taille	Zahnradgetriebe / Gear units / Réducteurs à engrenages										
	$b_1$	c	$e_4$	$f_1$	h	$h_1$	$h_2$	$h_3$	$m_2$	$n_1$	s
4	150	$30 \pm 1$	200	28	107.5	165	-	180	300	30	24
5 + 6	240	$30 \pm 1$	230	38	127.5	205	190	240	360	30	24
7 + 8	240	$36 \pm 1$	280	42	150	205	165	250	430	35	28
9 + 10	330	$45 \pm 1.5$	320	42	185	275	205	330	490	40	36
11 + 12	330	$54 \pm 1.5$	380	48	215	275	240	340	600	50	40

Größe Size Taille	Zahnradgetriebe / Gear units / Réducteurs à engrenages										
	a	$e_5$	$e_6$	E	$f_2$	$m_1$	$n_2$	$p_1$	$p_2$	Pumpe/Pump Pompe $f_3$ 2)	
4	565	215	320	270	22	505	160	35	220	-	
5	640	252	385	315	28	580	175	35	270	150	
6	720	252	425	350	28	660	220	35	270	150	
7	785	292	425	385	30	715	215	35	330	145	
8	890	302	485	430	32	820	275	35	330	145	
9	925	342	560	450	32	845	260	40	370	135	
10	1025	342	610	500	32	945	310	40	370	135	
11	1105	402	595	545	35	1005	295	50	440	145	
12	1260	410	680	615	35	1160	380	50	440	145	

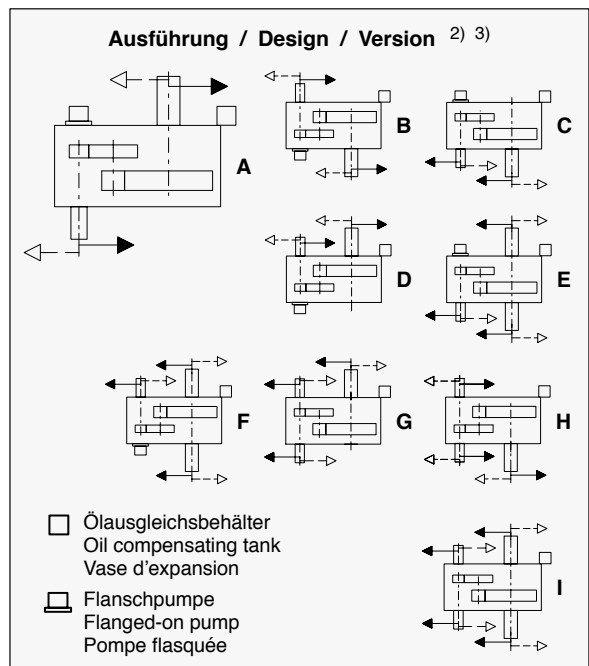

# Zahnradgetriebe

Zweistufig  
Vertikal  
Bauart H2.V  
Größen 4 - 12

# Gear Units

Two Stage  
Vertical  
Type H2.V  
Sizes 4 - 12

# Réducteurs à engrenages

à deux trains  
Vertical  
Type H2.V  
Tailles 4 - 12

## Abtrieb / Output / Sortie

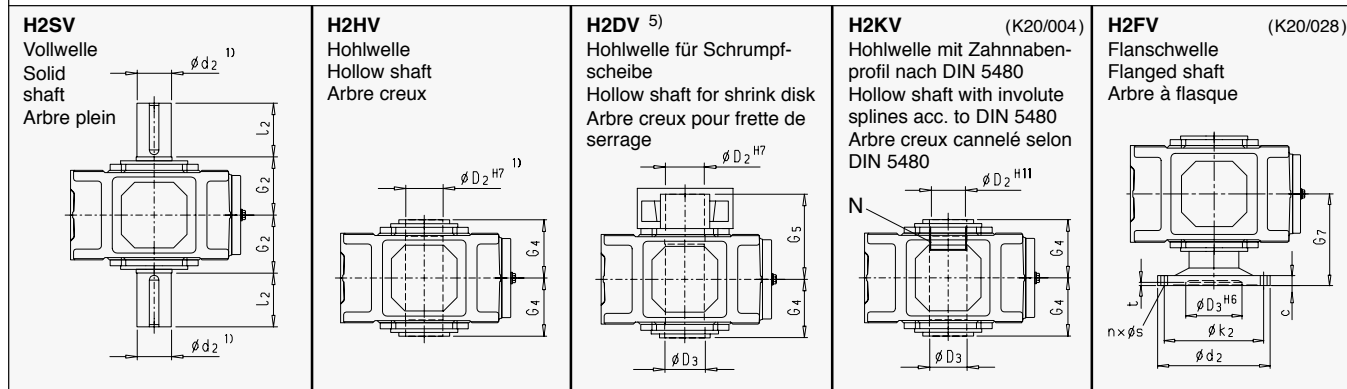

Größe Size Taille	H2SV			H2HV		H2DV				H2KV				H2FV							
	d <sub>2</sub>	l <sub>2</sub>	G <sub>2</sub>	D <sub>2</sub>	G <sub>4</sub>	D <sub>2</sub>	D <sub>3</sub>	G <sub>4</sub>	G <sub>5</sub>	N / DIN 5480		D <sub>2</sub>	D <sub>3</sub>	G <sub>4</sub>	c	d <sub>2</sub>	D <sub>3</sub>	k <sub>2</sub>	n x s	t	G <sub>7</sub>
4	80	170	140	80	140	85	85	140	205	-	-	-	-	-	-	-	-	-	-	-	-
5	100	210	165	95	165	100	100	165	240	N 95x3x30x30x9H	89	100	165	25	300	150	260	16 x 22	10	255	
6	110	210	165	105	165	110	110	165	240	N 95x3x30x30x9H	89	110	165	25	320	160	280	18 x 22	10	255	
7	120	210	195	115	195	120	120	195	280	N 120x3x30x38x9H	114	120	195	30	370	180	320	16 x 26	10	300	
8	130	250	195	125	195	130	130	195	285	N 120x3x30x38x9H	114	130	195	30	390	190	340	18 x 26	10	300	
9	140	250	235	135	235	140	145	235	330	N 140x3x30x45x9H	134	145	235	38	430	220	380	20 x 26	12	350	
10	160	300	235	150	235	150	155	235	350	N 140x3x30x45x9H	134	155	235	38	470	240	420	22 x 26	12	350	
11	170	300	270	165	270	165	170	270	400	N 170x5x30x32x9H	160	170	270	42	510	260	450	18 x 33	12	400	
12	180	300	270	180	270	180	185	270	405	N 170x5x30x32x9H	160	185	270	42	540	280	480	22 x 33	12	400	

Größe Size Taille	Ölmenge / Oil quantity Quantité de huile (l) <sup>*)</sup>		Gewicht / Weight Poids (kg) <sup>*)</sup> <sup>**)</sup>	
	Tauchs- schmierung Dip lubrication Lubrification par barbotage	Druck- schmierung Forced lubrication Lubrification sous pression	H2SV H2HV H2DV H2KV	H2FV
4	23	-	190	-
5	35	17.5	300	335
6	37	18.5	355	395
7	62	31	505	555
8	69	35	590	645
9	98	49	830	915
10	110	55	960	1050
11	160	80	1335	1465
12	180	90	1615	1755

**Kühlschlange / Cooling coil  
Serpentin de refroidissement** <sup>3)</sup>

Wasseranschluß für Kühlschlange G1/2"  
Water connection for cooling coil G1/2"  
Adduction pour serpentin de refroidissement G1/2"

Abtrieb  
Output  
Sortie

Größe Size Taille	m <sub>10</sub>	n <sub>10</sub>	e <sub>12</sub>	l/(min x)
4	34	140	155	4
5	68	166	170	4
6	70	162	215	4
7	100	197	210	4
8	100	197	270	4
9	140	210	245	8
10	100	225	295	8
11	110	285	275	8
12	200	271	360	8

Kühlschlange geeignet für Süß-, See- und Brackwasser  
Cooling coil suitable for fresh, sea and brackish water  
Serpentin de refroidissement adapté à l'eau douce, de mer et saumâtre

x) Erforderliche Kühlwassermenge, max. Kühlwasserdruck: 8 bar / Cooling water quantity required; max. cooling water pressure: 8 bar / Quantité d'eau de refroidissement nécessaire, pression maxi de l'eau de refroidissement: 8 bar

### Abmessungen in mm

- Wellen:**
    - m<sub>6</sub> ≤ ∅ 100; n<sub>6</sub> > ∅ 100
    - Paßfedernut nach DIN 6885/1, Nabennutbreite nach ISO JS9
    - Paßfeder nach DIN 6885/1 Form B
    - Einzelheiten siehe Seiten 126 - 135
  - Varianten:**
    - Flanscpumpe nicht in Verbindung mit Ausführung G, H und I.
  - Kühlschlange:**
    - Ausführungen A, C und E mit Druckschmierung durch Flanscpumpe nicht möglich.
  - Freiraum für Pumpe, Rohre und Deckel, genaue Maße ggf. anfragen.
  - Ausführungen A, D und G bei Hohlwellengetriebe auf Anfrage.
- \*) Richtwerte; genaue Angaben nach auftragsbezogener Dokumentation.  
\*\*) ohne Ölfüllung

### Dimensions in mm

- Shafts:**
    - m<sub>6</sub> ≤ ∅ 100; n<sub>6</sub> > ∅ 100
    - Keyway acc. to DIN 6885/1, Hub keyway width acc. to ISO JS9
    - Parallel key acc. to DIN 6885/1 form B
    - For details, see pages 126 - 135
  - Variants:**
    - Flanged-on pump not possible with G, H and I designs.
  - Cooling coil:**
    - For A, C and E designs, forced lubrication by flanged-on pump not possible.
  - Space for pump, pipes and cover; for exact dimensions, please refer to us.
  - A, D and G designs for gear units with hollow shaft on request.
- \*) Approximate values; exact data acc. to order-related documentation.  
\*\*) Without oil filling

### Dimensions en mm

- Arbres:**
    - m<sub>6</sub> ≤ ∅ 100; n<sub>6</sub> > ∅ 100
    - Rainure de clavette selon DIN 6885/1, Tolérance dans le moyeu selon ISO JS9
    - Clavette selon DIN 6885/1 forme B
    - Détails voir pages 126 - 135
  - Variantes:**
    - Impossibilité de monter une pompe attelée avec les exécutions G, H et I.
  - Serpentin de refroidissement:**
    - Impossibilité de livrer les exécutions A, C et E avec une lubrification sous pression par pompe attelée.
  - Espace libre pour passage pompe, tuyauterie et couvercle, côtes précises sur demande.
  - Exécutions A, D et G pour réducteurs à arbre creux sur demande.
- \*) Valeurs approximatives; données exactes selon documentation relative à la commande.  
\*\*) sans huile



# Zahnradgetriebe

Zweistufig  
Vertikal  
Bauarten H2.V  
Größen 13 - 22

# Gear Units

Two Stage  
Vertical  
Types H2.V  
Sizes 13 - 22

# Réducteurs à engrenages

à deux trains  
Vertical  
Types H2.V  
Tailles 13 - 22

H2SV  
H2HV  
H2DV  
H2KV  
H2FV

Druckschmierung durch Flanschpumpe  
Forced lubrication by flanged-on pump  
Lubrification sous pression par pompe flasquée

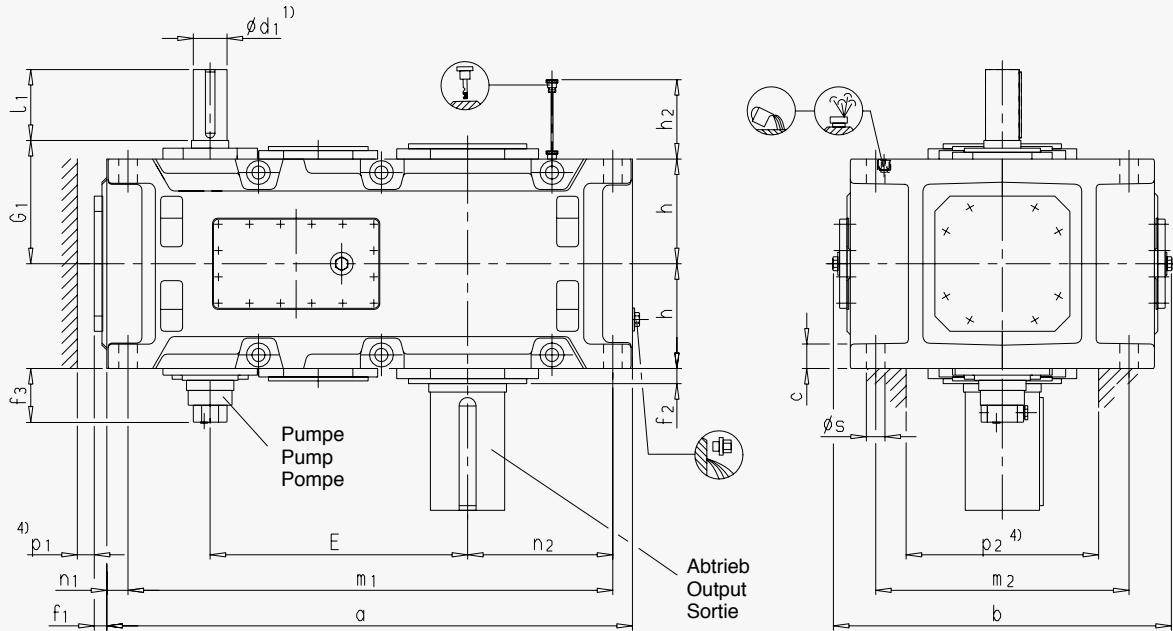

4

Größe Size Taille	Antrieb / Input / Entrée				G <sub>1</sub>	Ausführung / Design / Version G, H, I nur für / only for seulement pour i <sub>N</sub> =	
	i <sub>N</sub> = 6.3 - 11.2		i <sub>N</sub> = 12.5 - 20			6.3 - 16	8 - 20
	i <sub>N</sub> = 7.1 - 12.5		i <sub>N</sub> = 14 - 22.4				
	i <sub>N</sub> = 8 - 14		i <sub>N</sub> = 16 - 25				
	d <sub>1</sub>	l <sub>1</sub>	d <sub>1</sub>	l <sub>1</sub>			
13 + 14	100	205	85	170	330	6.3 - 16	8 - 20
15 + 16	120	210	100	210	365	6.3 - 16	7.1 - 18
17 + 18	125	245	110	210	420	6.3 - 16	7.1 - 18
19 + 20	Auf Anfrage / On request / Sur demande						
21 + 22	Auf Anfrage / On request / Sur demande						

Größe Size Taille	Zahnradgetriebe / Gear units / Réducteurs à engrenages							
	b	c	f <sub>1</sub>	h	h <sub>2</sub>	m <sub>2</sub>	n <sub>1</sub>	s
13 + 14	900	61 ± 2	53	272.5	300	680	50	48
15 + 16	980	72 ± 2	63	310	340	750	60	55
17 + 18	1110	81 ± 2	60	340	374	850	70	55
19 + 20	Auf Anfrage / On request / Sur demande							
21 + 22	Auf Anfrage / On request / Sur demande							

Größe Size Taille	Zahnradgetriebe / Gear units / Réducteurs à engrenages							
	a	E	f <sub>2</sub>	m <sub>1</sub>	n <sub>2</sub>	p <sub>1</sub>	p <sub>2</sub>	Pumpe/Pump Pompe f <sub>3</sub> 2)
13	1290	635	35	1195	360	50	500	130
14	1430	705	35	1335	430	50	500	130
15	1550	762	42	1435	430	50	570	130
16	1640	808	42	1525	475	50	570	130
17	1740	860	42	1610	465	70	630	170
18	1860	920	42	1730	525	70	630	170
19	Auf Anfrage / On request / Sur demande							
20	Auf Anfrage / On request / Sur demande							
21	Auf Anfrage / On request / Sur demande							
22	Auf Anfrage / On request / Sur demande							

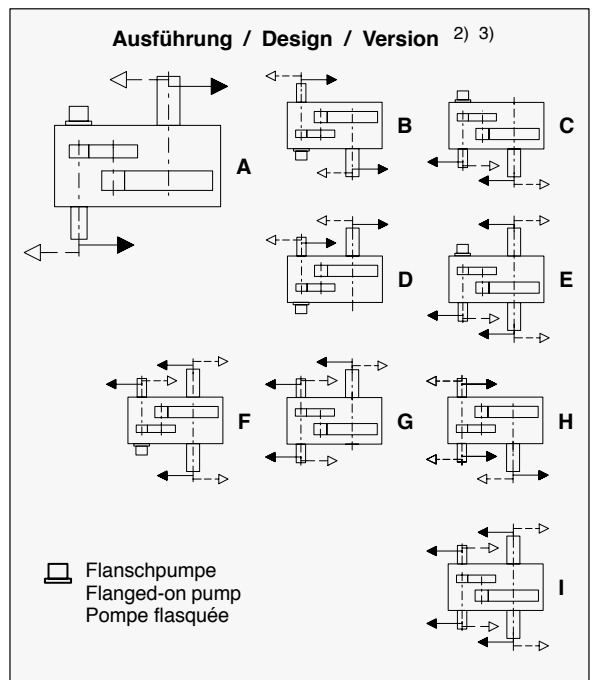

# Zahnradgetriebe

Zweistufig  
Vertikal  
Bauart H2.V  
Größen 13 - 22

# Gear Units

Two Stage  
Vertical  
Type H2.V  
Sizes 13 - 22

# Réducteurs à engrenages

à deux trains  
Vertical  
Type H2.V  
Tailles 13 - 22

## Abtrieb / Output / Sortie

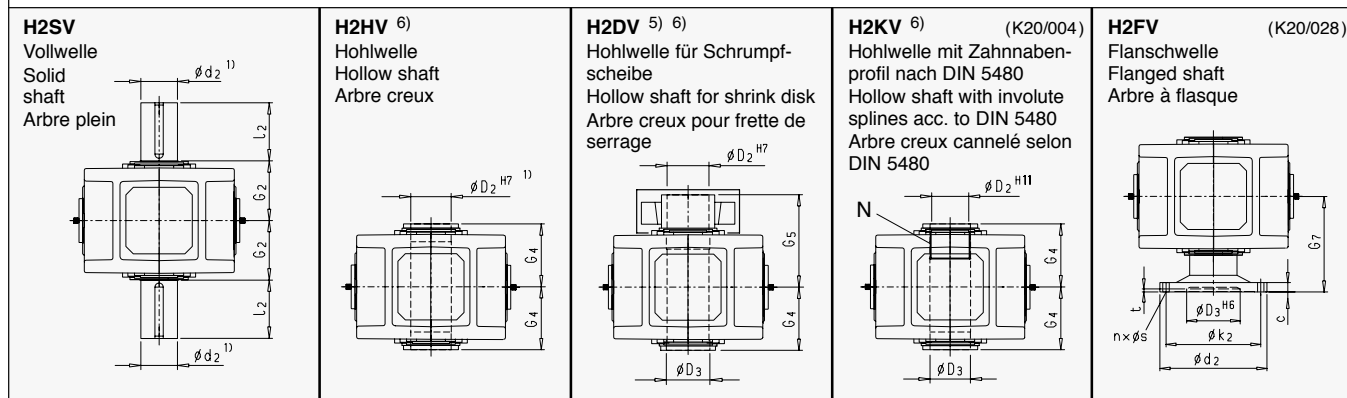

Größe Size Taille	H2SV			H2HV		H2DV				H2KV				H2FV									
	d <sub>2</sub>	l <sub>2</sub>	G <sub>2</sub>	D <sub>2</sub>	G <sub>4</sub>	D <sub>2</sub>	D <sub>3</sub>	G <sub>4</sub>	G <sub>5</sub>	N / DIN 5480				D <sub>2</sub>	D <sub>3</sub>	G <sub>4</sub>	c	d <sub>2</sub>	D <sub>3</sub>	k <sub>2</sub>	n x s	t	G <sub>7</sub>
13	200	350	335	190	335	190	195	335	480	N 190x5x30x36x9H				180	195	335	48	580	310	500	20 x 33	14	480
14	210	350	335	210	335	210	215	335	480	N 190x5x30x36x9H				180	215	335	48	620	310	540	24 x 33	14	480
15	230	410	380	230	380	230	235	380	550	N 220x5x30x42x9H				210	235	380	55	710	360	630	28 x 33	17	550
16	240	410	380	240	380	240	245	380	550	N 220x5x30x42x9H				210	245	380	55	740	360	660	30 x 33	17	550
17	250	410	415	250	415	250	260	415	600	N 250x5x30x48x9H				240	260	415	60	750	410	660	24 x 39	18	600
18	270	470	415	275	415	280	285	415	600	N 250x5x30x48x9H				240	285	415	60	800	410	710	26 x 39	18	600
19 - 22	Auf Anfrage / On request / Sur demande																						

Größe Size Taille	Ölmenge Oil quantity Quantité de huile (l) *	Gewicht / Weight Poids (kg) *) **	
		H2SV H2HV H2DV H2KV	H2FV
13	120	1880	2040
14	135	2430	2600
15	185	3240	3480
16	200	3465	3720
17	265	4420	4720
18	285	4870	5220
19 - 22	Auf Anfrage / On request Sur demande		

**Kühlschlange / Cooling coil  
Serpentin de refroidissement** <sup>3)</sup>

Wasseranschluß für Kühlschlange G1/2"  
Water connection for cooling coil G1/2"  
Adduction pour serpentin de refroidissement G1/2"

Abtrieb  
Output  
Sortie

Größe Size Taille	m <sub>10</sub>	n <sub>10</sub>	e <sub>12</sub>	l/(min x)
13	252	300	335	8
14	252	300	405	8
15	290	335	395	8
16	290	335	440	8
17	340	380	425	8
18	340	380	485	8
19 - 22	Auf Anfrage On request Sur demande			

Kühlschlange geeignet für Süß-, See- und Brackwasser  
Cooling coil suitable for fresh, sea and brackish water  
Serpentin de refroidissement adapté à l'eau douce, de mer et saumâtre

x) Erforderliche Kühlwassermenge, max. Kühlwasserdruck: 8 bar  
Cooling water quantity required, max. cooling water pressure: 8 bar  
Quantité d'eau de refroidissement nécessaire, pression maxi de l'eau de refroidissement: 8 bar

### Abmessungen in mm

- Wellen:**
    - m<sub>6</sub> ≤ ∅ 100; n<sub>6</sub> > ∅ 100
    - Paßfedernut nach DIN 6885/1, Nabennutbreite nach ISO JS9
    - Paßfeder nach DIN 6885/1 Form B
    - Einzelheiten siehe Seiten 126 - 135
  - Varianten:**
    - Flanscpumpe nicht in Verbindung mit Ausführung G, H und I.
  - Kühlschlange:**
    - Ausführungen A, C und E mit Druckschmierung durch Flanscpumpe nicht möglich.
  - Freiraum für Pumpe, Rohre und Deckel, genaue Maße ggf. anfragen.
  - Ausführungen A, D und G bei Hohlwellengetriebe auf Anfrage.
  - Größen 13 und 15: nur i<sub>N</sub> = 6.3 - 18  
Größen 17 und 19: nur i<sub>N</sub> = 6.3 - 16
- \*) Richtwerte; genaue Angaben nach auftragsbezogener Dokumentation.  
\*\*) ohne Ölfüllung

### Dimensions in mm

- Shafts:**
    - m<sub>6</sub> ≤ ∅ 100; n<sub>6</sub> > ∅ 100
    - Keyway acc. to DIN 6885/1, Hub keyway width acc. to ISO JS9
    - Parallel key acc. to DIN 6885/1 form B
    - For details, see pages 126 - 135
  - Variants:**
    - Flanged-on pump not possible with G, H and I designs.
  - Cooling coil:**
    - For A, C and E designs, forced lubrication by flanged-on pump not possible.
  - Space for pump, pipes and cover; for exact dimensions, please refer to us.
  - A, D and G designs for gear units with hollow shaft on request.
  - Sizes 13 and 15: only i<sub>N</sub> = 6.3 - 18  
Sizes 17 and 19: only i<sub>N</sub> = 6.3 - 16
- \*) Approximate values; exact data acc. to order-related documentation.  
\*\*) Without oil filling

### Dimensions en mm

- Arbres:**
    - m<sub>6</sub> ≤ ∅ 100; n<sub>6</sub> > ∅ 100
    - Rainure de clavette selon DIN 6885/1, Tolérance dans le moyeu selon ISO JS9
    - Clavette selon DIN 6885/1 forme B
    - Détails voir pages 126 - 135
  - Variantes:**
    - Impossibilité de monter une pompe attelée avec les exécutions G, H et I.
  - Serpentin de refroidissement:**
    - Impossibilité de livrer les exécutions A, C et E avec une lubrification sous pression par pompe attelée.
  - Espace libre pour passage pompe, tuyauterie et couvercle, côtes précises sur demande.
  - Exécutions A, D et G pour réducteurs à arbre creux sur demande.
  - Tailles 13 et 15: uniquement i<sub>N</sub> = 6.3 - 18  
Tailles 17 et 19: uniquement i<sub>N</sub> = 6.3 - 16
- \*) Valeurs approximatives; données exactes selon documentation relative à la commande.  
\*\*) sans huile



# Zahnradgetriebe

Dreistufig  
Vertikal  
Bauart H3.V  
Größen 5 - 12

# Gear Units

Three Stage  
Vertical  
Type H3.V  
Sizes 5 - 12

# Réducteurs à engrenages

à trois trains  
Vertical  
Type H3.V  
Tailles 5 - 12

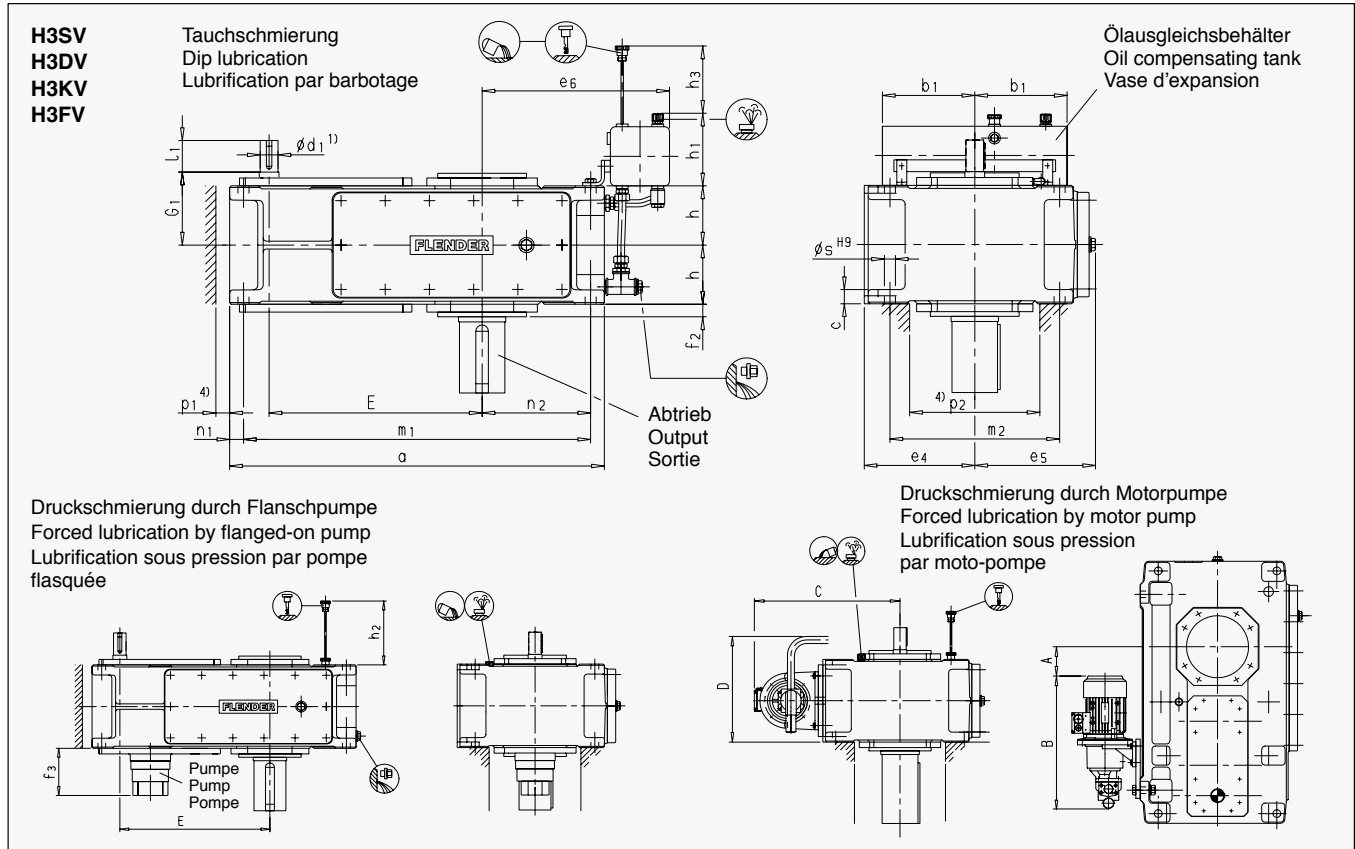

4

Größe Size Taille	Antrieb / Input / Entrée							Ausführung / Design / Version G, H, I nur für / only for seulement pour $i_N =$	
	$i_N = 25 - 45$		$i_N = 50 - 63$		$i_N = 71 - 90$		$G_1$		
	$i_N = 31.5 - 56$	$d_1$	$l_1$	$d_1$	$l_1$	$d_1$		$l_1$	
5 + 6	40	70	30	50	24	40	160	25 - 90	31.5 - 112
7 + 8	45	80	35	60	28	50	185	25 - 90	31.5 - 112
9 + 10	60	125	45	100	32	80	230	25 - 90	31.5 - 112
11 + 12	70	120	50	80	42	70	255	25 - 90	31.5 - 112

Größe Size Taille	Zahnradgetriebe / Gear units / Réducteurs à engrenages											
	$b_1$	c	$e_4$	h	$h_1$	$h_2$	$h_3$	$m_2$	$n_1$	$p_1$	$p_2$	s
5 + 6	240	$30 \pm 1$	230	127.5	205	190	240	360	30	35	270	24
7 + 8	240	$36 \pm 1$	280	150	205	165	250	430	35	35	330	28
9 + 10	330	$45 \pm 1.5$	320	185	275	205	330	490	40	40	370	36
11 + 12	330	$54 \pm 1.5$	380	215	275	240	340	600	50	50	440	40

Größe Size Taille	Zahnradgetriebe / Gear units / Réducteurs à engrenages															
	a	$e_5$	$e_6$	E	$f_2$	$m_1$	$n_2$	Pumpe Pump Pompe $f_3$ 2)				Motorpumpe / Motor pump / Moto-pompe				
								A +)	B +)	C +)	D +)	A +)	B +)	C +)	D +)	
5	690	252	385	405	28	630	175	190	-35	490	480	360				
6	770	252	425	440	28	710	220	190	0	490	480	360				
7	845	292	425	495	30	775	215	185	60	490	530	420				
8	950	302	485	540	32	880	275	185	105	490	530	420				
9	1000	342	560	580	32	920	260	170	-5	490	570	480				
10	1100	342	610	630	32	1020	310	170	45	490	570	480				
11	1200	402	595	705	35	1100	295	170	80	490	630	550				
12	1355	410	680	775	35	1255	380	170	150	490	630	550				

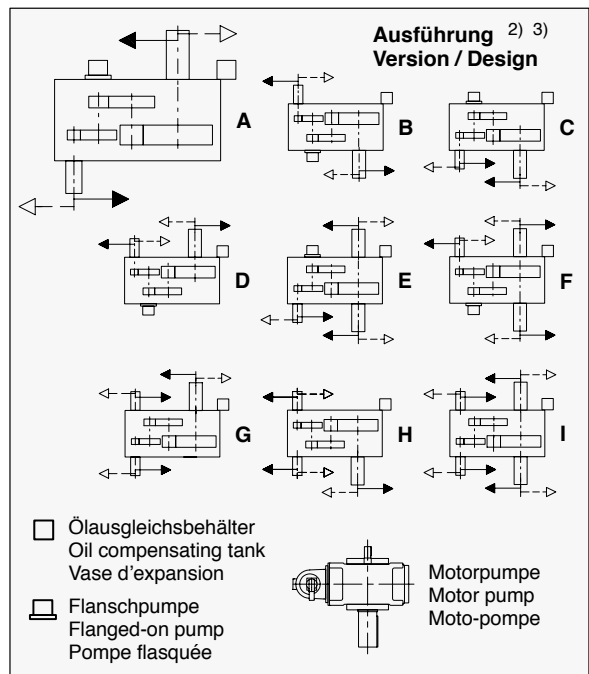

+) max. Abmessungen; Einzelheiten nach auftragsbezogener Dokumentation.

+) Max. dimensions; details acc. to order-related documentation.

+) Dimensions maximales; détails selon documentation relative à la commande.

# Zahnradgetriebe

Dreistufig  
Vertikal  
Bauart H3.V  
Größen 5 - 12

# Gear Units

Three Stage  
Vertical  
Type H3.V  
Sizes 5 - 12

# Réducteurs à engrenages

à trois trains  
Vertical  
Type H3.V  
Tailles 5 - 12

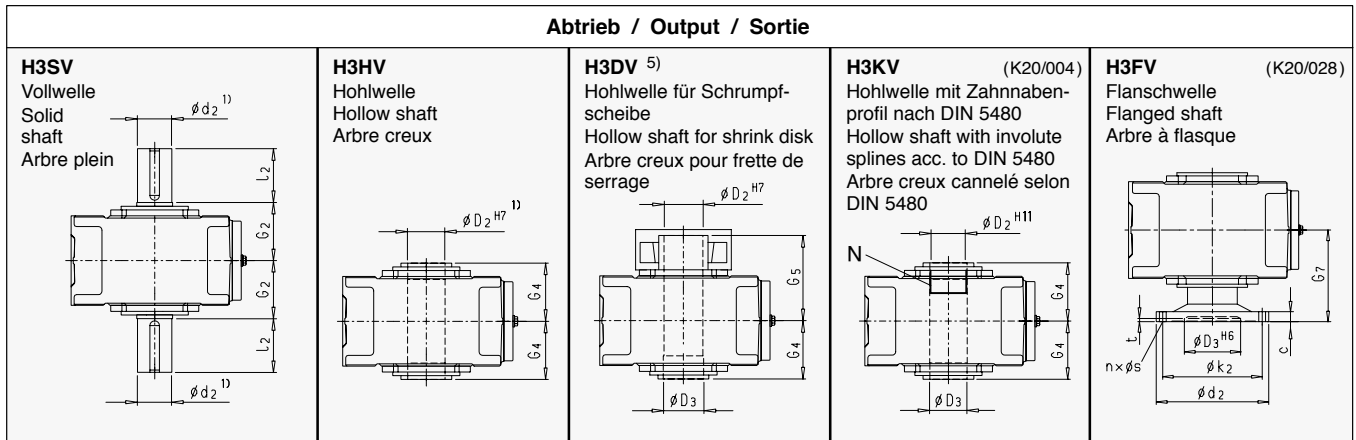

Größe Size Taille	H3SV			H3HV		H3DV				H3KV				H3FV									
	d <sub>2</sub>	l <sub>2</sub>	G <sub>2</sub>	D <sub>2</sub>	G <sub>4</sub>	D <sub>2</sub>	D <sub>3</sub>	G <sub>4</sub>	G <sub>5</sub>	N / DIN 5480				c	d <sub>2</sub>	D <sub>3</sub>	k <sub>2</sub>	n x s	t	G <sub>7</sub>			
5	100	210	165	95	165	100	100	165	240	N 95x3x30x30x9H				89	100	165	25	300	150	260	16 x 22	10	255
6	110	210	165	105	165	110	110	165	240	N 95x3x30x30x9H				89	110	165	25	320	160	280	18 x 22	10	255
7	120	210	195	115	195	120	120	195	280	N 120x3x30x38x9H				114	120	195	30	370	180	320	16 x 26	10	300
8	130	250	195	125	195	130	130	195	285	N 120x3x30x38x9H				114	130	195	30	390	190	340	18 x 26	10	300
9	140	250	235	135	235	140	145	235	330	N 140x3x30x45x9H				134	145	235	38	430	220	380	20 x 26	12	350
10	160	300	235	150	235	150	155	235	350	N 140x3x30x45x9H				134	155	235	38	470	240	420	22 x 26	12	350
11	170	300	270	165	270	165	170	270	400	N 170x5x30x32x9H				160	170	270	42	510	260	450	18 x 33	12	400
12	180	300	270	180	270	180	185	270	405	N 170x5x30x32x9H				160	185	270	42	540	280	480	22 x 33	12	400

Größe Size Taille	Ölmenge / Oil quantity Quantité de huile (l) *)		Gewicht / Weight Poids (kg) **)	
	Tauchschmierung Dip lubrication Lubrification par barbotage	Druckschmierung Forced lubrication Lubrification sous pression	H3SV H3HV H3DV H3KV	H3FV
5	36	24	320	355
6	40	27	365	405
7	64	42	540	590
8	70	47	625	680
9	110	73	875	960
10	120	80	1020	1110
11	190	110	1400	1530
12	205	120	1675	1815

**Kühlschlange / Cooling coil  
Serpentin de refroidissement** <sup>3)</sup>

Wasseranschluß für Kühlschlange G1/2"  
Water connection for cooling coil G1/2"  
Adduction pour serpentin de refroidissement G1/2"

Abtrieb  
Output  
Sortie

Kühlschlange geeignet für Süß-, See- und Brackwasser  
Cooling coil suitable for fresh, sea and brackish water  
Serpentin de refroidissement adapté à l'eau douce, de mer et saumâtre

Größe Size Taille	m <sub>10</sub>	n <sub>10</sub>	e <sub>12</sub>	l/min x)
5	70	170	175	4
6	70	161	220	4
7	80	197	210	4
8	80	197	270	4
9	150	213	245	4
10	90	225	295	4
11	200	265	275	8
12	200	265	360	8

x) Erforderliche Kühlwassermenge, max. Kühlwasserdruck: 8 bar / Cooling water quantity required; max. cooling water pressure: 8 bar / Quantité d'eau de refroidissement nécessaire, pression maxi de l'eau de refroidissement: 8 bar

**Abmessungen in mm**

- Wellen:**
    - k<sub>6</sub> = Ø 24; Ø 28 ≥ m<sub>6</sub> ≤ Ø 100; n<sub>6</sub> > Ø 100
    - Paßfedernut nach DIN 6885/1, Nabennutbreite nach ISO JS9
    - Paßfeder nach DIN 6885/1 Form B
    - Einzelheiten siehe Seiten 126 - 135
  - Varianten:**
    - Flanscpumpe nicht in Verbindung mit Ausführung G, H und I.
  - Kühlschlange:**
    - Ausführungen A, C und E mit Druckschmierung durch Flanscpumpe nicht möglich.
    - Kombination mit Druckschmierung durch Motorpumpe auf Anfrage.
  - Freiraum für Pumpe, Rohre und Deckel, genaue Maße ggf. anfragen.
  - Ausführungen A, D und G bei Hohlwellengetriebe auf Anfrage.
- \*) Richtwerte; genaue Angaben nach auftragsbezogener Dokumentation.  
\*\*) ohne Ölfüllung

**Dimensions in mm**

- Shafts:**
    - k<sub>6</sub> = Ø 24; Ø 28 ≥ m<sub>6</sub> ≤ Ø 100; n<sub>6</sub> > Ø 100
    - Keyway acc. to DIN 6885/1, Hub keyway width acc. to ISO JS9
    - Parallel key acc. to DIN 6885/1 form B
    - For details, see pages 126 - 135
  - Variants:**
    - Flanged-on pump not possible with G, H and I designs.
  - Cooling coil:**
    - For A, C and E designs, forced lubrication by flanged-on pump not possible.
    - Combination with forced lubrication by motor pump on request.
  - Space for pump, pipes and cover; for exact dimensions, please refer to us.
  - A, D and G designs for gear units with hollow shaft on request.
- \*) Approximate values; exact data acc. to order-related documentation.  
\*\*) Without oil filling

**Dimensions en mm**

- Arbres:**
    - k<sub>6</sub> = Ø 24; Ø 28 ≥ m<sub>6</sub> ≤ Ø 100; n<sub>6</sub> > Ø 100
    - Rainure de clavette selon DIN 6885/1, Tolérance dans le moyeu selon ISO JS9
    - Clavette selon DIN 6885/1 forme B
    - Détails voir pages 126 - 135
  - Variantes:**
    - Impossibilité de monter une pompe attelée avec les exécutions G, H et I.
  - Serpentin de refroidissement:**
    - Impossibilité de livrer les exécutions A, C et E avec une lubrification sous pression par pompe attelée.
    - Combination avec lubrification sous pression par moto-pompe sur demande.
  - Espace libre pour passage pompe, tuyauterie et couvercle, côtes précises sur demande.
  - Exécutions A, D et G pour réducteurs à arbre creux sur demande.
- \*) Valeurs approximatives; données exactes selon documentation relative à la commande.  
\*\*) sans huile



# Zahnradgetriebe

Dreistufig  
Vertikal  
Bauart H3.V  
Größen 13 - 22

# Gear Units

Three Stage  
Vertical  
Type H3.V  
Sizes 13 - 22

# Réducteurs à engrenages

à trois trains  
Vertical  
Type H3.V  
Tailles 13 - 22

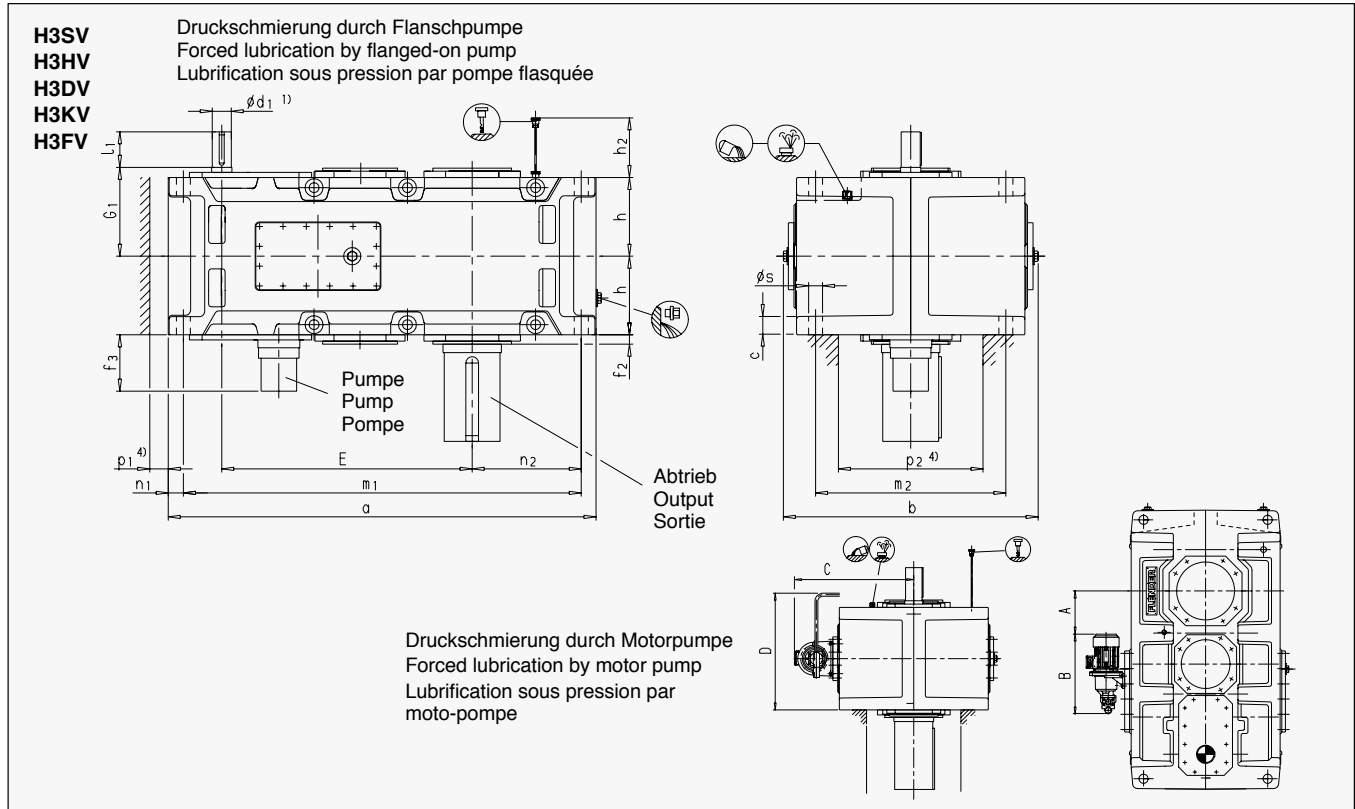

4

Größe Size Taille	Antrieb / Input / Entrée						G <sub>1</sub>	Ausführung / Design / Version G, H, I nur für / only for seulement pour i <sub>N</sub> =	
	i <sub>N</sub> = 22.4 - 45		i <sub>N</sub> = 50 - 63		i <sub>N</sub> = 71 - 90			22.4 - 90	28 - 112
	i <sub>N</sub> = 25 - 50		i <sub>N</sub> = 56 - 71		i <sub>N</sub> = 80 - 100				
	i <sub>N</sub> = 28 - 56		i <sub>N</sub> = 63 - 80		i <sub>N</sub> = 90 - 112				
	d <sub>1</sub>	l <sub>1</sub>	d <sub>1</sub>	l <sub>1</sub>	d <sub>1</sub>	l <sub>1</sub>			
13 + 14	85	160	60	135	50	110	310		
15 + 16	100	200	75	140	60	140	350	22.4 - 90	25 - 100
17 + 18	100	200	75	140	60	140	380	22.4 - 90	25 - 100
19 + 20	Auf Anfrage / On request / Sur demande								
21 + 22									

Größe Size Taille	Zahnradgetriebe / Gear units / Réducteurs à engrenages								
	b	c	h	h <sub>2</sub>	m <sub>2</sub>	n <sub>1</sub>	p <sub>1</sub>	p <sub>2</sub>	s
13 + 14	900	61 ± 2	272.5	300	680	50	50	500	48
15 + 16	980	72 ± 2	310	340	750	60	50	570	55
17 + 18	1110	81 ± 2	340	374	850	70	70	630	55
19 + 20	Auf Anfrage / On request / Sur demande								
21 + 22									

Größe Size Taille	Zahnradgetriebe / Gear units / Réducteurs à engrenages									
	a	E	f <sub>2</sub>	m <sub>1</sub>	n <sub>2</sub>	Pumpe Pump Pompe f <sub>3</sub> 2)	Motorpumpe / Motor pump Moto-pompe			
							A +)	B +)	C +)	D +)
13	1395	820	35	1300	360	170	115	580	685	700
14	1535	890	35	1440	430	170	185	580	685	700
15	1680	987	42	1565	430	170	260	580	730	780
16	1770	1033	42	1655	475	170	305	580	730	780
17	1770	1035	42	1640	465	210	235	580	790	840
18	1890	1095	42	1760	525	210	295	580	790	840
19 + 20	Auf Anfrage / On request / Sur demande									
21 + 22										

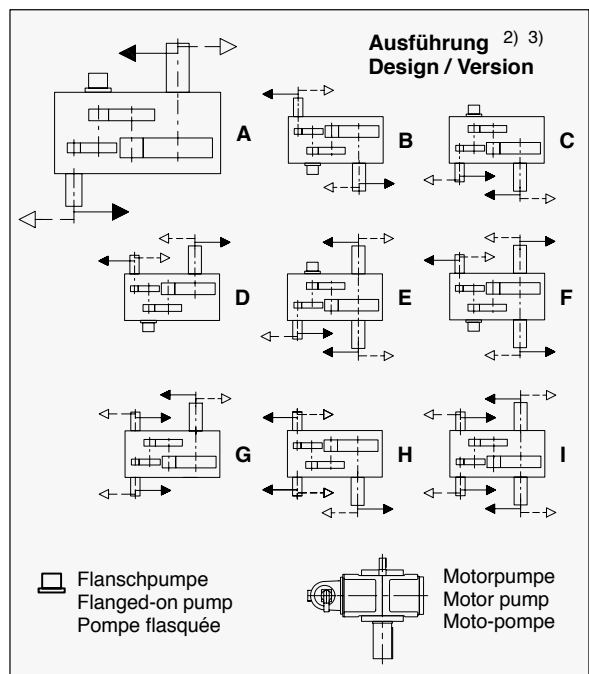

+) max. Abmessungen; Einzelheiten nach auftragsbezogener Dokumentation.

+) Max. dimensions; details acc. to order-related documentation.

+) Dimensions maximales; détails selon documentation relative à la commande.



# Zahnradgetriebe

Dreistufig  
Vertikal  
Bauart H3.V  
Größen 13 - 22

# Gear Units

Three Stage  
Vertical  
Type H3.V  
Sizes 13 - 22

# Réducteurs à engrenages

à trois trains  
Vertical  
Type H3.V  
Tailles 13 - 22

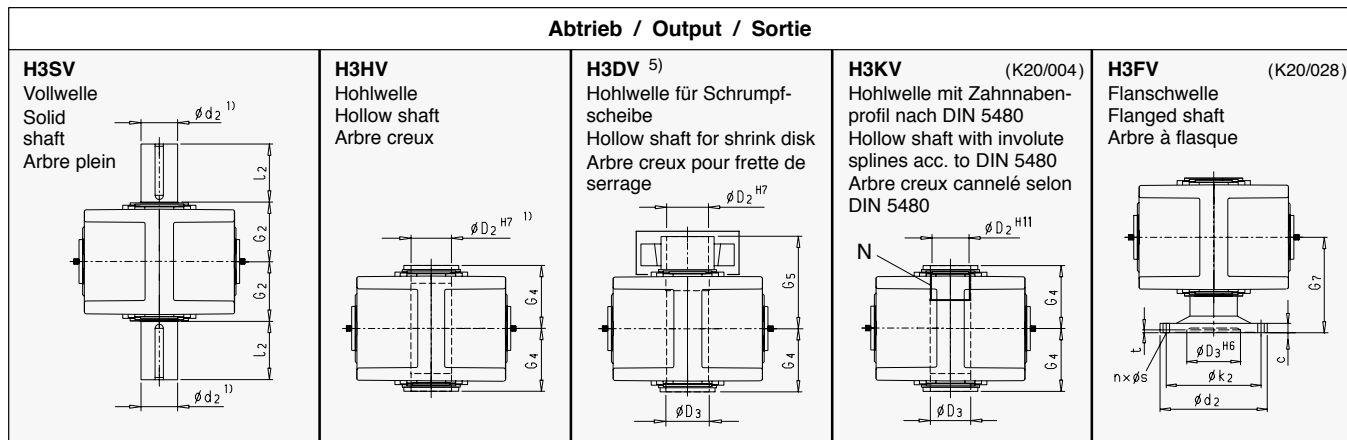

Größe Size Taille	H3SV			H3HV		H3DV				H3KV				H3FV									
	d <sub>2</sub>	l <sub>2</sub>	G <sub>2</sub>	D <sub>2</sub>	G <sub>4</sub>	D <sub>2</sub>	D <sub>3</sub>	G <sub>4</sub>	G <sub>5</sub>	N / DIN 5480				D <sub>2</sub>	D <sub>3</sub>	G <sub>4</sub>	c	d <sub>2</sub>	D <sub>3</sub>	k <sub>2</sub>	n x s	t	G <sub>7</sub>
13	200	350	335	190	335	190	195	335	480	N 190x5x30x36x9H				180	195	335	48	580	310	500	20 x 33	14	480
14	210	350	335	210	335	210	215	335	480	N 190x5x30x36x9H				180	215	335	48	620	310	540	24 x 33	14	480
15	230	410	380	230	380	230	235	380	550	N 220x5x30x42x9H				210	235	380	55	710	360	630	28 x 33	17	550
16	240	410	380	240	380	240	245	380	550	N 220x5x30x42x9H				210	245	380	55	740	360	660	30 x 33	17	550
17	250	410	415	250	415	250	260	415	600	N 250x5x30x48x9H				240	260	415	60	750	410	660	24 x 39	18	600
18	270	470	415	275	415	280	285	415	600	N 250x5x30x48x9H				240	285	415	60	800	410	710	26 x 39	18	600
19 - 22	Auf Anfrage / On request / Sur demande																						

Größe Size Taille	Ölmenge Oil quantity Quantité de huile (l) *	Gewicht / Weight Poids (kg) **)	
		H3SV H3HV H3DV H3KV	H3FV
13	160	2155	2315
14	180	2490	2660
15	255	3260	3500
16	260	3625	3880
17	325	4250	4550
18	335	4740	5090
19 - 22	Auf Anfrage / On request Sur demande		

**Kühlschlange / Cooling coil  
Serpentin de refroidissement** <sup>3)</sup>

Wasseranschluß für Kühlschlange G1/2"  
Water connection for cooling coil G1/2"  
Adduction pour serpentin de refroidissement G1/2"

Größe Size Taille	m <sub>10</sub>	n <sub>10</sub>	e <sub>12</sub>	l/(min x)
13	252	300	335	8
14	252	300	405	8
15	290	340	395	8
16	290	340	440	8
17	300	380	425	8
18	300	380	485	8
19 - 22	Auf Anfrage On request Sur demande			

Kühlschlange geeignet für Süß-, See- und Brackwasser  
Cooling coil suitable for fresh, sea and brackish water  
Serpentin de refroidissement adapté à l'eau douce, de mer et saumâtre

x) Erforderliche Kühlwassermenge, max. Kühlwasserdruck: 8 bar  
Cooling water quantity required; max. cooling water pressure: 8 bar  
Quantité d'eau de refroidissement nécessaire, pression maxi de l'eau de refroidissement: 8 bar

### Abmessungen in mm

- Wellen:**
    - m<sub>6</sub> ≤ Ø 100; n<sub>6</sub> > Ø 100
    - Paßfedernut nach DIN 6885/1, Nabennutbreite nach ISO JS9
    - Paßfeder nach DIN 6885/1 Form B
    - Einzelheiten siehe Seiten 126 - 135
  - Varianten:**
    - Flanscpumpe nicht in Verbindung mit Ausfuhrung G, H und I.
  - Kühlschlange:**
    - Ausfuhrungen A, C und E mit Druckschmierung durch Flanscpumpe nicht möglich.
    - Kombination mit Druckschmierung durch Motorpumpe auf Anfrage.
  - Freiraum für Pumpe, Rohre und Deckel, genaue Maße ggf. anfragen.
  - Ausfuhrungen A, D und G bei Hohlwellengetriebe auf Anfrage.
- \*) Richtwerte; genaue Angaben nach auftragsbezogener Dokumentation.  
\*\*) ohne Ölfüllung

### Dimensions in mm

- Shafts:**
    - m<sub>6</sub> ≤ Ø 100; n<sub>6</sub> > Ø 100
    - Keyway acc. to DIN 6885/1, Hub keyway width acc. to ISO JS9
    - Parallel key acc. to DIN 6885/1 form B
    - For details, see pages 126 - 135
  - Variants:**
    - Flanged-on pump not possible with G, H and I designs.
  - Cooling coil:**
    - For A, C and E designs, forced lubrication by flanged-on pump not possible.
    - Combination with forced lubrication by motor pump on request.
  - Space for pump, pipes and cover; for exact dimensions, please refer to us.
  - A, D and G designs for gear units with hollow shaft on request.
- \*) Approximate values; exact data acc. to order-related documentation.  
\*\*) Without oil filling

### Dimensions en mm

- Arbres:**
    - m<sub>6</sub> ≤ Ø 100; n<sub>6</sub> > Ø 100
    - Rainure de clavette selon DIN 6885/1, Tolérance dans le moyeu selon ISO JS9
    - Clavette selon DIN 6885/1 forme B
    - Détails voir pages 126 - 135
  - Variantes:**
    - Impossibilité de monter une pompe attelée avec les exécutions G, H et I.
  - Serpentin de refroidissement:**
    - Impossibilité de livrer les exécutions A, C et E avec une lubrification sous pression par pompe attelée.
    - Combinaison avec lubrification sous pression par moto-pompe sur demande.
  - Espace libre pour passage pompe, tuyauterie et couvercle, côtes précises sur demande.
  - Exécutions A, D et G pour réducteurs à arbre creux sur demande.
- \*) Valeurs approximatives; données exactes selon documentation relative à la commande.  
\*\*) sans huile



# Zahnradgetriebe

Vierstufig  
Vertikal  
Bauart H4.V  
Größen 7 - 12

# Gear Units

Four Stage  
Vertical  
Type H4.V  
Sizes 7 - 12

# Réducteurs à engrenages

à quatre trains  
Vertical  
Type H4.V  
Tailles 7 - 12

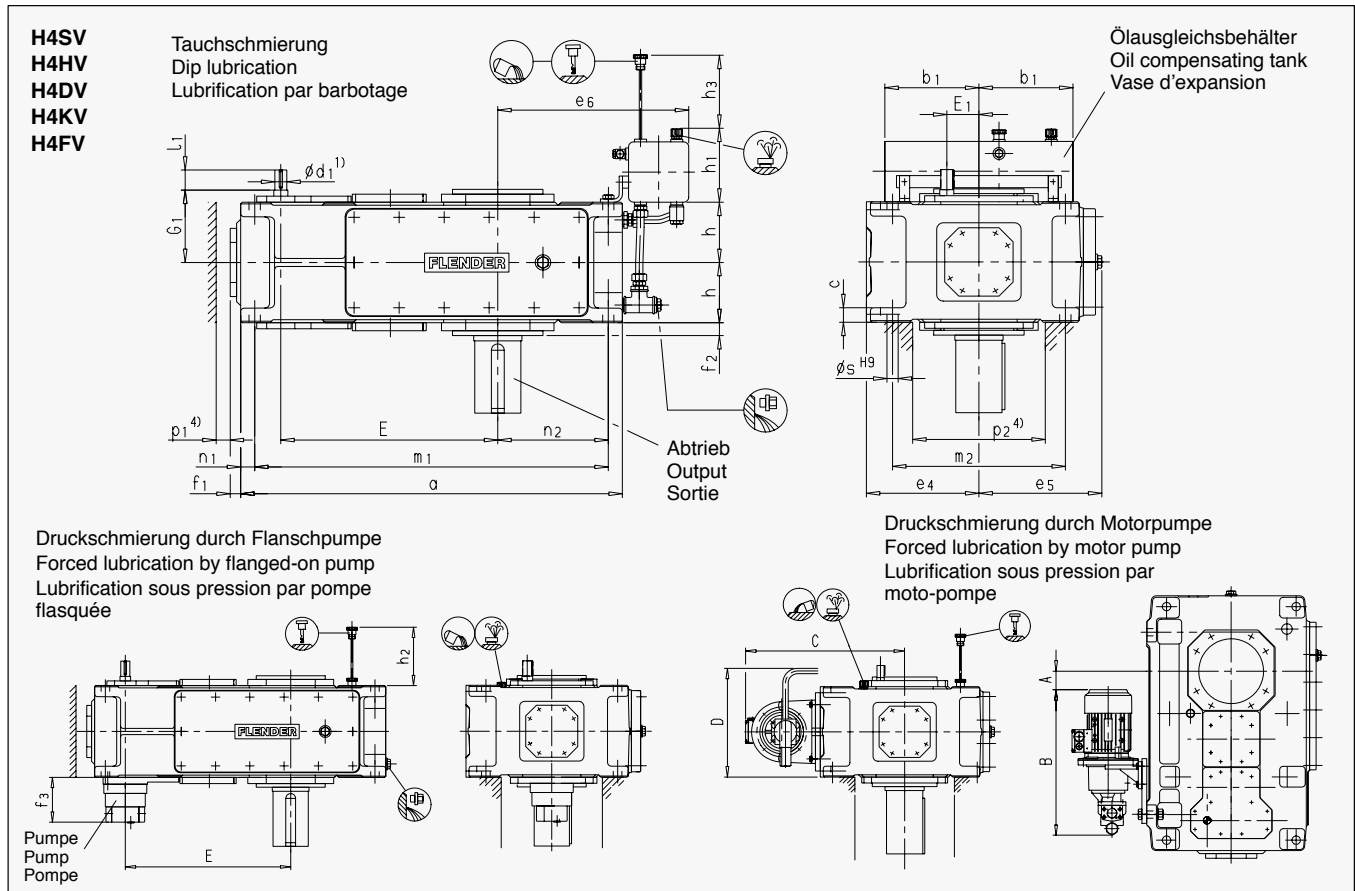

4

Größe Size Taille	Antrieb / Input / Entrée					Ausführung / Design Version <b>G, H, I</b> nur für / only for / seulement pour $i_N =$	
	$i_N = 100 - 180$		$i_N = 200 - 355$		$G_1$	100 - 224	125 - 280
	$d_1$	$l_1$	$d_1$	$l_1$			
<b>7 + 8</b>	30	50	24	40	180		
<b>9 + 10</b>	35	60	28	50	215	100 - 250	125 - 315
<b>11 + 12</b>	45	100	32	80	250	100 - 250	125 - 315

Größe Size Taille	Zahnradgetriebe / Gear units / Réducteurs à engrenages													
	$b_1$	$c$	$e_4$	$E_1$	$f_1$	$h$	$h_1$	$h_2$	$h_3$	$m_2$	$n_1$	$p_1$	$p_2$	$s$
<b>7 + 8</b>	240	$36 \pm 1$	280	80	37	150	205	165	250	430	35	35	330	28
<b>9 + 10</b>	330	$45 \pm 1.5$	320	90	43	185	275	205	330	490	40	40	370	36
<b>11 + 12</b>	330	$54 \pm 1.5$	380	110	47	215	275	240	340	600	50	50	440	40

Größe Size Taille	Zahnradgetriebe / Gear units / Réducteurs à engrenages												
	$a$	$e_5$	$e_6$	$E$	$f_2$	$m_1$	$n_2$	Pumpe Pump Pompe $f_3$	Motorpumpe / Motor pump / Moto-pompe A+) B+) C+) D+)				
<b>7</b>	845	292	425	495	30	775	215	160	10	580	540	410	
<b>8</b>	950	302	485	540	32	880	275	160	55	580	540	410	
<b>9</b>	1000	342	560	580	32	920	260	170	-55	580	580	480	
<b>10</b>	1100	342	610	630	32	1020	310	170	-5	580	580	480	
<b>11</b>	1200	402	595	705	35	1100	295	170	30	580	640	550	
<b>12</b>	1355	410	680	775	35	1255	380	170	100	580	640	550	

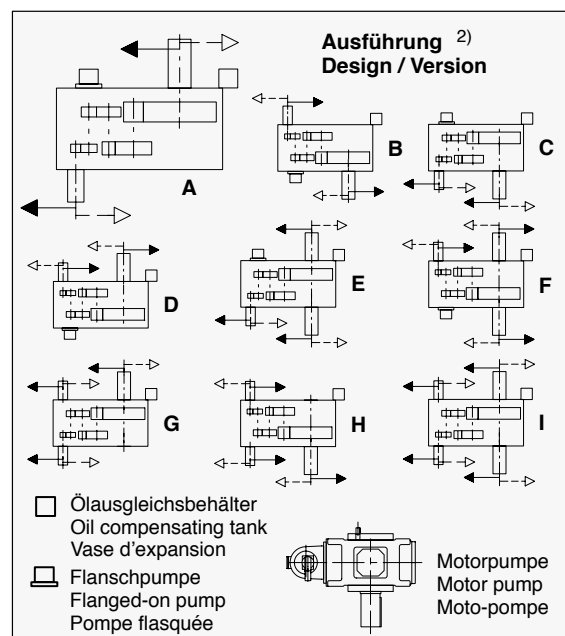

+) max. Abmessungen; Einzelheiten nach auftragsbezogener Dokumentation.

+) Max. dimensions; details acc. to order-related documentation.

+) Dimensions maximales; détails selon documentation relative à la commande.

# Zahnradgetriebe

Vierstufig  
Vertikal  
Bauart H4.V  
Größen 7 - 12

# Gear Units

Four Stage  
Vertical  
Type H4.V  
Sizes 7 - 12

# Réducteurs à engrenages

à quatre trains  
Vertical  
Type H4.V  
Tailles 7 - 12

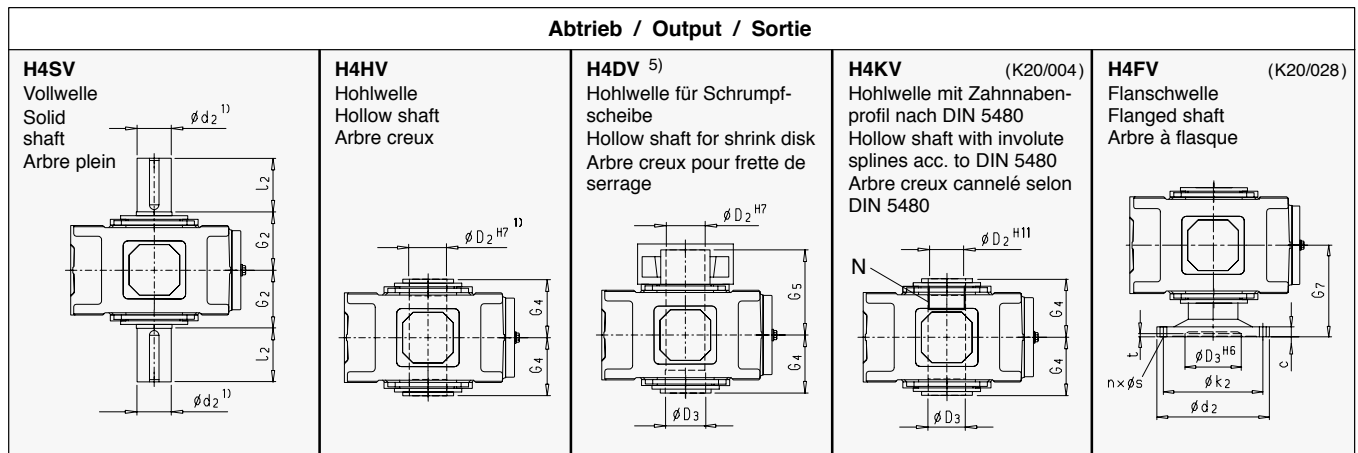

Größe Size Taille	H4SV			H4HV		H4DV				H4KV				H4FV									
	d <sub>2</sub>	l <sub>2</sub>	G <sub>2</sub>	D <sub>2</sub>	G <sub>4</sub>	D <sub>2</sub>	D <sub>3</sub>	G <sub>4</sub>	G <sub>5</sub>	N / DIN 5480				D <sub>2</sub>	D <sub>3</sub>	G <sub>4</sub>	c	d <sub>2</sub>	D <sub>3</sub>	k <sub>2</sub>	n x s	t	G <sub>7</sub>
7	120	210	195	115	195	120	120	195	280	N 120x3x30x38x9H				114	120	195	30	370	180	320	16 x 26	10	300
8	130	250	195	125	195	130	130	195	285	N 120x3x30x38x9H				114	130	195	30	390	190	340	18 x 26	10	300
9	140	250	235	135	235	140	145	235	330	N 140x3x30x45x9H				134	145	235	38	430	220	380	20 x 26	12	350
10	160	300	235	150	235	150	155	235	350	N 140x3x30x45x9H				134	155	235	38	470	240	420	22 x 26	12	350
11	170	300	270	165	270	165	170	270	400	N 170x5x30x32x9H				160	170	270	42	510	260	450	18 x 33	12	400
12	180	300	270	180	270	180	185	270	405	N 170x5x30x32x9H				160	185	270	42	540	280	480	22 x 33	12	400

Größe Size Taille	Ölmenge Oil quantity Quantité de huile (l) <sup>*)</sup>		Gewicht Weight / Poids (kg) <sup>*)</sup> <sup>**)</sup>	
	Tauchschmierung Dip lubrication Lubrification par barbotage	Druckschmierung Forced lubrication Lubrification sous pression	H4SV H4HV H4DV H4KV	H4FV
7	60	44	550	600
8	65	48	645	700
9	105	78	875	960
10	110	81	1010	1100
11	175	113	1460	1590
12	200	129	1725	1865

Abmessungen in mm

**1) Wellen:**

- $k_6 = \phi 24$ ;  $\phi 28 \geq m_6 \leq \phi 100$ ;  $n_6 > \phi 100$
- Paßfedernut nach DIN 6885/1, Nabennutbreite nach ISO JS9
- Paßfeder nach DIN 6885/1 Form B
- Einzelheiten siehe Seiten 126 - 135

**2) Varianten:**

- Flanschpumpe nicht in Verbindung mit Ausführung G, H und I.

4) Freiraum für Pumpe, Rohre und Deckel, genaue Maße ggf. anfragen.

5) Ausführungen A und D bei Hohlwellenge triebe auf Anfrage.

\*) Richtwerte; genaue Angaben nach auftragsbezogener Dokumentation.

\*\*\*) ohne Ölfüllung

Dimensions in mm

**1) Shafts:**

- $k_6 = \phi 24$ ;  $\phi 28 \geq m_6 \leq \phi 100$ ;  $n_6 > \phi 100$
- Keyway acc. to DIN 6885/1, Hub keyway width acc. to ISO JS9
- Parallel key acc. to DIN 6885/1 form B
- For details, see pages 126 - 135

**2) Variants:**

- Flanged-on pump not possible with G, H and I designs.

4) Space for pump, pipes and cover; for exact dimensions, please refer to us.

5) A and D designs for gear units with hollow shaft on request.

\*) Approximate values; exact data acc. to order-related documentation.

\*\*\*) Without oil filling

Dimensions en mm

**1) Arbres:**

- $k_6 = \phi 24$ ;  $\phi 28 \geq m_6 \leq \phi 100$ ;  $n_6 > \phi 100$
- Rainure de clavette selon DIN 6885/1, Tolérance dans le moyeu selon ISO JS9
- Clavette selon DIN 6885/1 forme B
- Détails voir pages 126 - 135

**2) Variantes:**

- Impossibilité de monter une pompe attelée avec les exécutions G, H et I.

4) Espace libre pour passage pompe, tuyauterie et couvercle, côtes précises sur demande.

5) Exécutions A et D pour réducteurs à arbre creux sur demande.

\*) Valeurs approximatives; données exactes selon documentation relative à la commande.

\*\*\*) sans huile

# Zahnradgetriebe

Vierstufig  
Vertikal  
Bauart H4.V  
Größen 13 - 22

# Gear Units

Four Stage  
Vertical  
Type H4.V  
Sizes 13 - 22

# Réducteurs à engrenages

à quatre trains  
Vertical  
Type H4.V  
Tailles 13 - 22

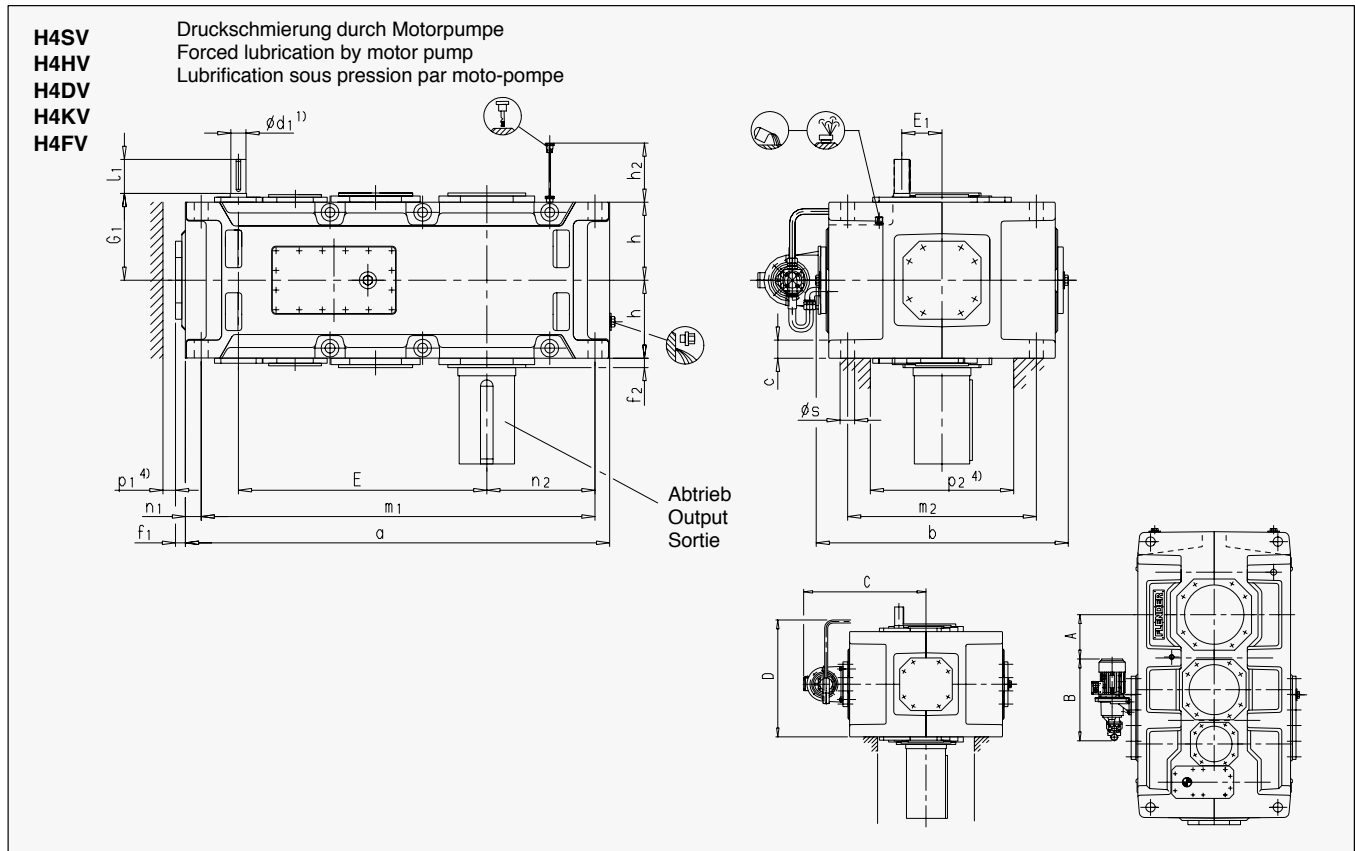

Größe Size Taille	Antrieb / Input / Entrée				G <sub>1</sub>	Ausführung / Design Version G, H, I nur für / only for / seulement pour i <sub>N</sub> =		
	i <sub>N</sub> = 100 - 180		i <sub>N</sub> = 200 - 355			100 - 250	125 - 315	
	i <sub>N</sub> = 112 - 200		i <sub>N</sub> = 224 - 400					
	i <sub>N</sub> = 125 - 224		i <sub>N</sub> = 250 - 450					
	d <sub>1</sub>	l <sub>1</sub>	d <sub>1</sub>	l <sub>1</sub>				
13 + 14	50	100	38	80	305	100 - 250	125 - 315	
15 + 16	60	135	50	110	345	100 - 250	112 - 280	
17 + 18	60	105	50	80	380	-	-	
19 + 20	Auf Anfrage / On request / Sur demande							
21 + 22	Auf Anfrage / On request / Sur demande							

Größe Size Taille	Zahnradgetriebe / Gear units / Réducteurs à engrenages									
	b	c	E <sub>1</sub>	h	h <sub>2</sub>	m <sub>2</sub>	n <sub>1</sub>	p <sub>1</sub>	p <sub>2</sub>	s
13 + 14	900	61 ± 2	130	272.5	300	680	50	50	500	48
15 + 16	980	72 ± 2	160	310	340	750	60	60	570	55
17 + 18	1110	81 ± 2	160	340	374	850	70	70	630	55
19 + 20	Auf Anfrage / On request / Sur demande									
21 + 22	Auf Anfrage / On request / Sur demande									

Größe Size Taille	Zahnradgetriebe / Gear units / Réducteurs à engrenages									
	a	E	f <sub>1</sub>	f <sub>2</sub>	m <sub>1</sub>	n <sub>2</sub>	Motorpumpe / Motor pump Moto-pompe			
A +)							B +)	C +)	D +)	
13	1395	820	47	35	1300	360	70	580	690	705
14	1535	890	47	35	1440	430	140	580	690	705
15	1680	987	56	42	1565	430	210	580	730	780
16	1770	1033	56	42	1655	475	260	580	730	780
17	1770	1035	53	42	1640	465	190	580	790	840
18	1890	1095	53	42	1760	525	250	580	790	840
19 + 20	Auf Anfrage / On request / Sur demande									
21 + 22	Auf Anfrage / On request / Sur demande									

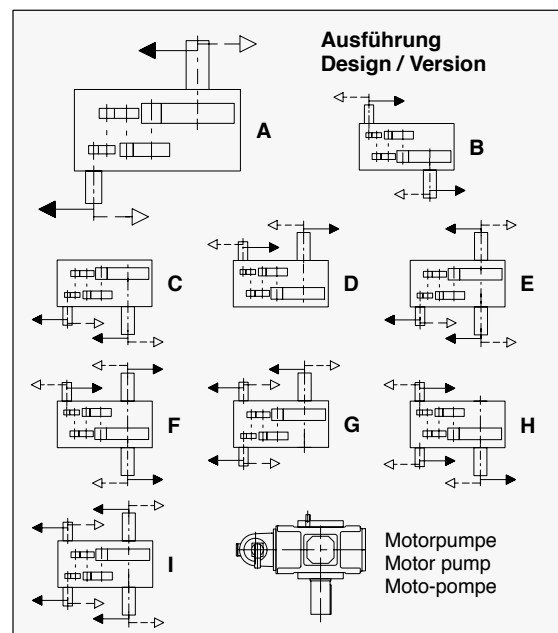

+ ) max. Abmessungen; Einzelheiten nach auftragsbezogener Dokumentation.

+ ) Max. dimensions; details acc. to order-related documentation.

+ ) Dimensions maximales; détails selon documentation relative à la commande.

# Zahnradgetriebe

Vierstufig  
Vertikal  
Bauart H4.V  
Größen 13 - 22

# Gear Units

Four Stage  
Vertical  
Type H4.V  
Sizes 13 - 22

# Réducteurs à engrenages

à quatre trains  
Vertical  
Type H4.V  
Tailles 13 - 22

## Abtrieb / Output / Sortie

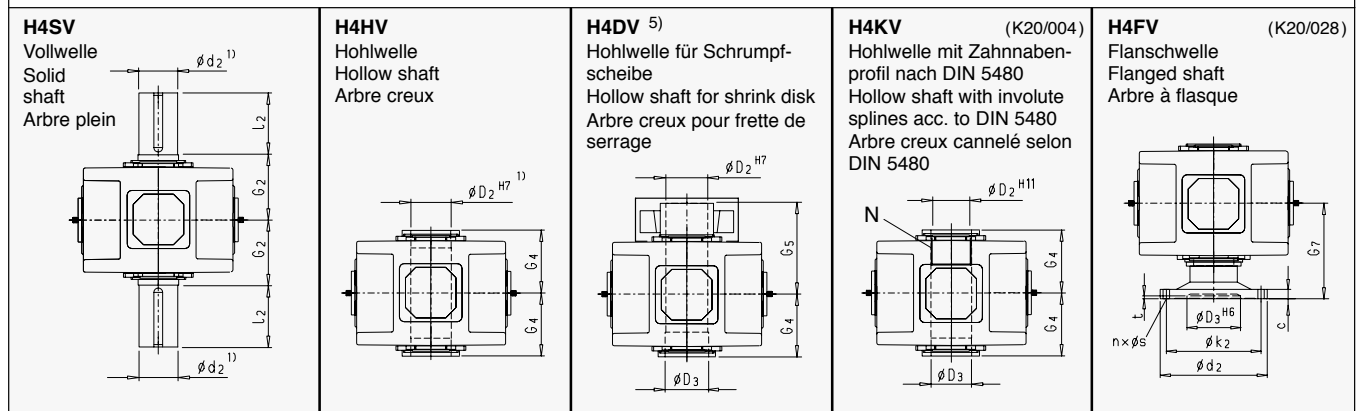

Größe Size Taille	H4SV			H4HV		H4DV				H4KV				H4FV						
	d <sub>2</sub>	l <sub>2</sub>	G <sub>2</sub>	D <sub>2</sub>	G <sub>4</sub>	D <sub>2</sub>	D <sub>3</sub>	G <sub>4</sub>	G <sub>5</sub>	N / DIN 5480	D <sub>2</sub>	D <sub>3</sub>	G <sub>4</sub>	c	d <sub>2</sub>	D <sub>3</sub>	k <sub>2</sub>	n x s	t	G <sub>7</sub>
13	200	350	335	190	335	190	195	335	480	N 190x5x30x36x9H	180	195	335	48	580	310	500	20 x 33	14	480
14	210	350	335	210	335	210	215	335	480	N 190x5x30x36x9H	180	215	335	48	620	310	540	24 x 33	14	480
15	230	410	380	230	380	230	235	380	550	N 220x5x30x42x9H	210	235	380	55	710	360	630	28 x 33	17	550
16	240	410	380	240	380	240	245	380	550	N 220x5x30x42x9H	210	245	380	55	740	360	660	30 x 33	17	550
17	250	410	415	250	415	250	260	415	600	N 250x5x30x48x9H	240	260	415	60	750	410	660	24 x 39	18	600
18	270	470	415	275	415	280	285	415	600	N 250x5x30x48x9H	240	285	415	60	800	410	710	26 x 39	18	600
19 - 22	Auf Anfrage / On request / Sur demande																			

Größe Size Taille	Ölmenge Oil quantity Quantité de huile (l) *)	Gewicht Weight / Poids (kg) **)	
		H4SV H4HV H4DV H4KV	H4FV
13	140	2270	2430
14	160	2600	2770
15	220	3440	3680
16	230	3740	3995
17	280	4445	4745
18	300	4915	5265
19 - 22	Auf Anfrage / On request Sur demande		

Abmessungen in mm

### 1) Wellen:

- $m_6 \leq \varnothing 100$ ;  $n_6 > \varnothing 100$
- Paßfedernut nach DIN 6885/1, Nabennutbreite nach ISO JS9
- Paßfeder nach DIN 6885/1 Form B
- Einzelheiten siehe Seiten 126 - 135

4) Freiraum für Pumpe, Rohre und Deckel, genaue Maße ggf. anfragen.

5) Ausführungen A und D bei Hohlwellenge-triebe auf Anfrage.

\*) Richtwerte; genaue Angaben nach auftrags-bezogener Dokumentation.

\*\*) ohne Ölfüllung

Dimensions in mm

### 1) Shafts:

- $m_6 \leq \varnothing 100$ ;  $n_6 > \varnothing 100$
- Keyway acc. to DIN 6885/1, Hub keyway width acc. to ISO JS9
- Parallel key acc. to DIN 6885/1 form B
- For details, see pages 126 - 135

4) Space for pump, pipes and cover; for exact dimensions, please refer to us.

5) A and D designs for gear units with hollow shaft on request.

\*) Approximate values; exact data acc. to order-related documentation.

\*\*) Without oil filling

Dimensions en mm

### 1) Arbres:

- $m_6 \leq \varnothing 100$ ;  $n_6 > \varnothing 100$
- Rainure de clavette selon DIN 6885/1, Tolérance dans le moyeu selon ISO JS9
- Clavette selon DIN 6885/1 forme B
- Détails voir pages 126 - 135

4) Espace libre pour passage pompe, tuyauterie et couvercle, côtes précises sur demande.

5) Exécutions A et D pour réducteurs à arbre creux sur demande.

\*) Valeurs approximatives; données exactes selon documentation relative à la commande.

\*\*) sans huile

# Zahnradgetriebe

Zweistufig  
Vertikal  
Bauart B2.V  
Größen 4 - 12

# Gear Units

Two Stage  
Vertical  
Type B2.V  
Sizes 4 - 12

# Réducteurs à engrenages

à deux trains  
Vertical  
Type B2.V  
Tailles 4 - 12

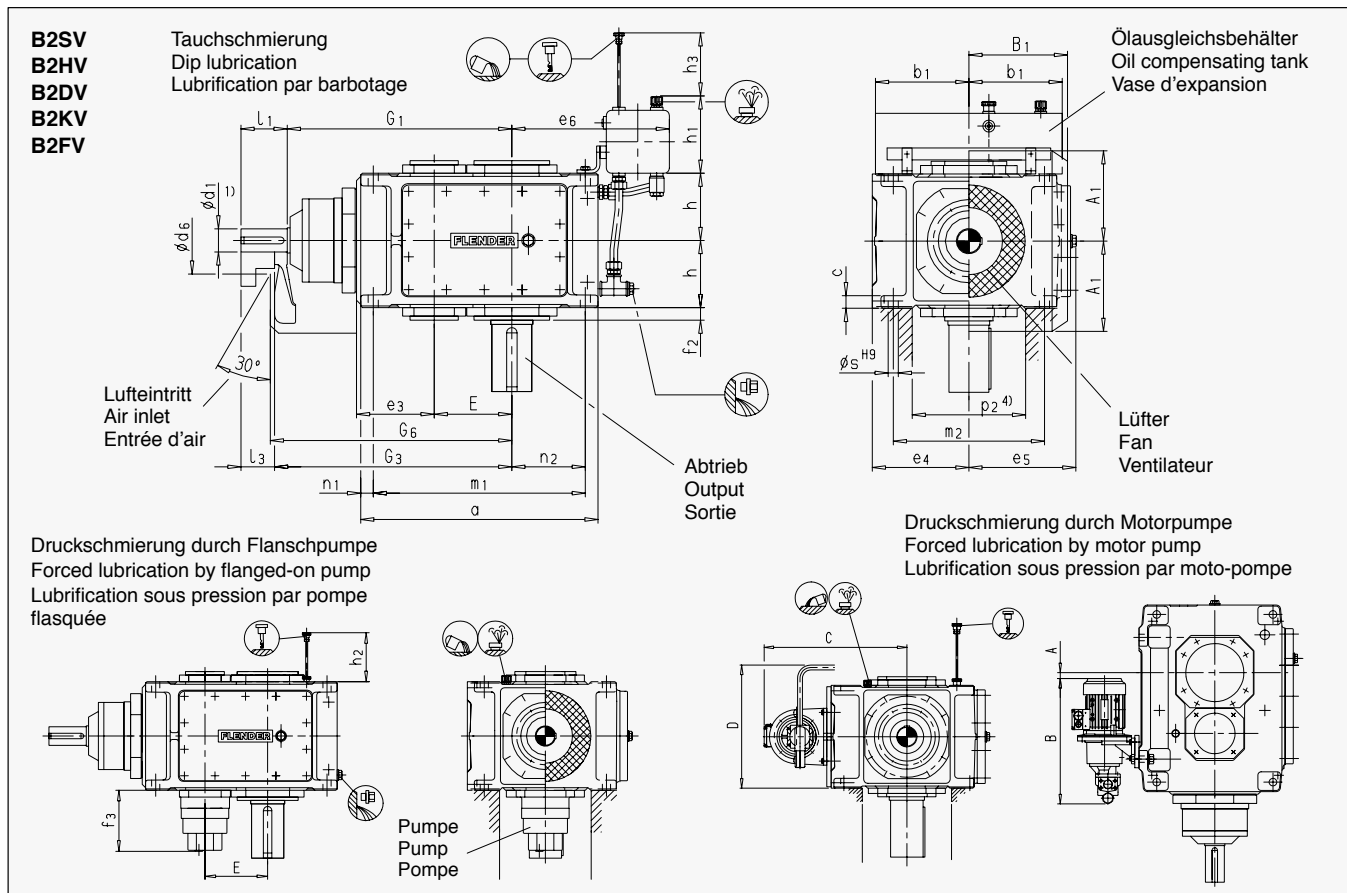

4

Größe Size Taille	Antrieb / Input / Entrée								Lüfter / Fan / Ventilateur		
	$i_N = 5 - 11.2$			$G_1$	$G_3$	$G_1$	$G_3$	$A_1$	$B_1$	$d_6$	
	$d_1$	$l_1$	$l_3$								
4	45	100	80	465	485	-	-	188	200	150	
5 + 6	55	110	80	535	565	570	600	215	235	160	
7 + 8	70	135	105	640	670	685	715	250	285	210	
9 + 10	80	165	130	755	790	805	840	270	325	195	
11 + 12	90	165	130	925	960	995	1030	328	385	210	

Größe Size Taille	Zahnradgetriebe / Gear units / Réducteurs à engrenages												
	$b_1$	$c$	$e_3$	$e_4$	$e_5$	$f_2$	$h$	$h_1$	$h_2$	$h_3$	$m_2$	$n_1$	$s$
4	150	$30 \pm 1$	100	200	215	26	135	165	-	180	300	30	24
5 + 6	240	$30 \pm 1$	185	230	252	30	160	205	245	240	360	30	24
7 + 8	240	$36 \pm 1$	225	280	302	32	190	205	220	250	430	35	28
9 + 10	330	$45 \pm 1.5$	265	320	342	45	220	275	250	330	490	40	36
11 + 12	330	$54 \pm 1.5$	320	380	410	47	265	275	300	340	600	50	40

Größe Size Taille	Zahnradgetriebe / Gear units / Réducteurs à engrenages												
	$a$	$e_6$	$E$	$G_6$	$m_1$	$n_2$	$p_2$	Pumpe Pump Pompe $f_3$	Motorpumpe / Motor pump / Moto-pompe				
									A +)	B +)	C +)	D +)	
4	505	320	160	495	445	160	220	-	-	-	-	-	
5	565	385	185	575	505	175	270	190	-130	490	480	420	
6	645	425	220	610	585	220	270	190	-90	490	480	420	
7	690	425	225	685	620	215	330	200	0	490	530	470	
8	795	485	270	730	725	275	330	200	45	490	530	470	
9	820	560	265	805	740	260	370	200	5	490	570	530	
10	920	610	315	855	840	310	370	200	55	490	570	530	
11	975	595	320	980	875	295	440	200	145	489	630	630	
12	1130	680	390	1050	1030	380	440	200	215	490	630	630	

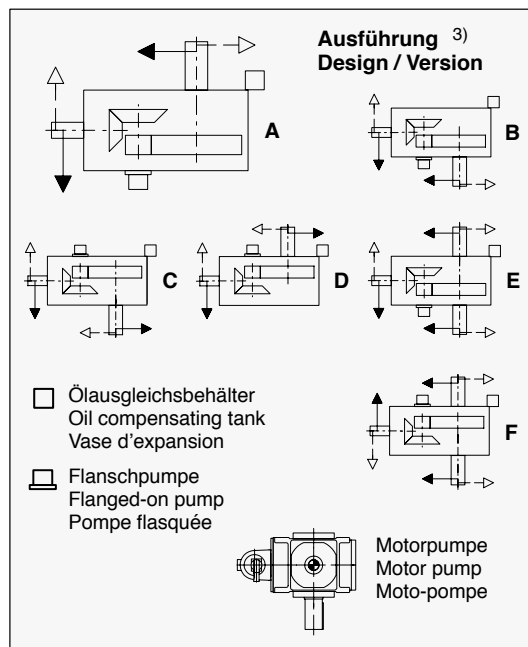

+) max. Abmessungen; Einzelheiten nach auftragsbezogener Dokumentation.

+) Max. dimensions; details acc. to order-related documentation.

+) Dimensions maximales; détails selon documentation relative à la commande.

# Zahnradgetriebe

Zweistufig  
Vertikal  
Bauart B2.V  
Größen 4 - 12

# Gear Units

Two Stage  
Vertical  
Type B2.V  
Sizes 4 - 12

# Réducteurs à engrenages

à deux trains  
Vertical  
Type B2.V  
Tailles 4 - 12

## Abtrieb / Output / Sortie

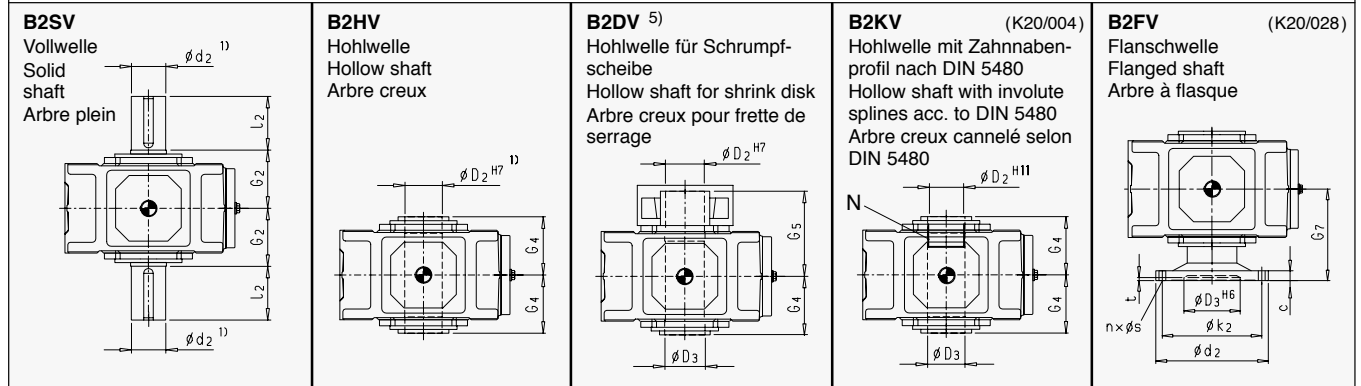

Größe Size Taille	B2SV			B2HV		B2DV				B2KV				B2FV									
	d <sub>2</sub>	l <sub>2</sub>	G <sub>2</sub>	D <sub>2</sub>	G <sub>4</sub>	D <sub>2</sub>	D <sub>3</sub>	G <sub>4</sub>	G <sub>5</sub>	N / DIN 5480				D <sub>2</sub>	D <sub>3</sub>	G <sub>4</sub>	c	d <sub>2</sub>	D <sub>3</sub>	k <sub>2</sub>	n x s	t	G <sub>7</sub>
4	80	170	170	80	170	85	85	170	235	-	-	-	-	-	-	-	-	-	-	-	-	-	-
5	100	210	200	95	200	100	100	200	275	N 95x3x30x30x9H	89	100	200	25	300	150	260	16 x 22	10	290			
6	110	210	200	105	200	110	110	200	275	N 95x3x30x30x9H	89	110	200	25	320	160	280	18 x 22	10	290			
7	120	210	235	115	235	120	120	235	320	N 120x3x30x38x9H	114	120	235	30	370	180	320	16 x 26	10	340			
8	130	250	235	125	235	130	130	235	325	N 120x3x30x38x9H	114	130	235	30	390	190	340	18 x 26	10	340			
9	140	250	270	135	270	140	145	270	365	N 140x3x30x45x9H	134	145	270	38	430	220	380	20 x 26	12	385			
10	160	300	270	150	270	150	155	270	385	N 140x3x30x45x9H	134	155	270	38	470	240	420	22 x 26	12	385			
11	170	300	320	165	320	165	170	320	450	N 170x5x30x32x9H	160	170	320	42	510	260	450	18 x 33	12	450			
12	180	300	320	180	320	180	185	320	455	N 170x5x30x32x9H	160	185	320	42	540	280	480	22 x 33	12	450			

Größe Size Taille	Ölmenge / Oil quantity Quantité de huile (l) *)		Gewicht / Weight Poids (kg) *) **)	
	Tauchs- schmierung Dip lubrication Lubrification par barbotage	Druck- schmierung Forced lubrication Lubrification sous pression	B2SV B2HV B2DV B2KV	B2FV
4	23.5	-	235	-
5	38	19	360	400
6	46	23	410	455
7	74	37	615	670
8	81	40	700	760
9	115	57	1000	1090
10	120	60	1155	1250
11	190	95	1640	1775
12	225	114	1910	2060

### Kühlschlange / Cooling coil Serpentin de refroidissement

Wasseranschluß für Kühlschlange G1/2"  
Water connection for cooling coil G1/2"  
Adduction pour serpentin de refroidissement G1/2"

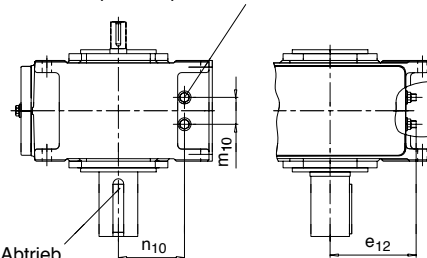

Abtrieb  
Output  
Sortie

Kühlschlange geeignet für Süß-, See- und Brackwasser  
Cooling coil suitable for fresh, sea and brackish water  
Serpentin de refroidissement adapté à l'eau douce, de mer et saumâtre

x) Erforderliche Kühlwassermenge, max. Kühlwasserdruck: 8 bar / Cooling water quantity required; max. cooling water pressure: 8 bar / Quantité d'eau de refroidissement nécessaire, pression maxi de l'eau de refroidissement: 8 bar

Größe Size Taille	m <sub>10</sub>	n <sub>10</sub>	e <sub>12</sub>	l/min x)
4	74	146	160	4
5	130	168	175	8
6	120	162	220	4
7	140	200	210	8
8	140	200	270	4
9	232	210	245	8
10	150	230	295	8
11	312	265	275	8
12	300	265	360	8

### Abmessungen in mm

- 1) **Wellen:**
- m<sub>6</sub> ≤ Ø 100; n<sub>6</sub> > Ø 100
  - Paßfedernut nach DIN 6885/1, Nabennutbreite nach ISO JS9
  - Paßfeder nach DIN 6885/1 Form B
  - Einzelheiten siehe Seiten 126 - 135

- 3) **Kühlschlange:**
- Ausführungen C, D und F mit Druckschmierung durch Flanscpumpe nicht möglich.
  - Kombination mit Druckschmierung durch Motorpumpe auf Anfrage.
- 4) Freiraum für Pumpe, Rohre und Deckel, genaue Maße ggf. anfragen.
- 5) Ausführungen A und D bei Hohlwellenge triebe auf Anfrage.

\*) Richtwerte; genaue Angaben nach auftrags- bezogener Dokumentation.

\*\*) ohne Ölfüllung

### Dimensions in mm

- 1) **Shafts:**
- m<sub>6</sub> ≤ Ø 100; n<sub>6</sub> > Ø 100
  - Keyway acc. to DIN 6885/1, Hub keyway width acc. to ISO JS9
  - Parallel key acc. to DIN 6885/1 form B
  - For details, see pages 126 - 135

- 3) **Cooling coil:**
- For C, D and F designs, forced lubrication by flanged-on pump not possible.
  - Combination with forced lubrication by motor pump on request.
- 4) Space for pump, pipes and cover; for exact dimensions, please refer to us.
- 5) A and D designs for gear units with hollow shaft on request.

\*) Approximate values; exact data acc. to order-related documentation.

\*\*) Without oil filling

### Dimensions en mm

- 1) **Arbres:**
- m<sub>6</sub> ≤ Ø 100; n<sub>6</sub> > Ø 100
  - Rainure de clavette selon DIN 6885/1, Tolérance dans le moyeu selon ISO JS9
  - Clavette selon DIN 26885/1 forme B
  - Détails voir pages 126 - 135

- 3) **Serpentin de refroidissement:**
- Impossibilité de livrer les exécutions C, D et F avec une lubrification sous pression par pompe attelée.
  - Combinaison avec lubrification sous pression par moto-pompe sur demande.
- 4) Espace libre pour passage pompe, tuyauterie et couvercle, côtes précises sur demande.
- 5) Exécutions A et D pour réducteurs à arbre creux sur demande.

\*) Valeurs approximatives; données exactes selon documentation relative à la commande.

\*\*) sans huile

# Zahnradgetriebe

Zweistufig  
Vertikal  
Bauart B2.V  
Größen 13 - 18

# Gear Units

Two Stage  
Vertical  
Type B2.V  
Sizes 13 - 18

# Réducteurs à engrenages

à deux trains  
Vertical  
Type B2.V  
Tailles 13 - 18

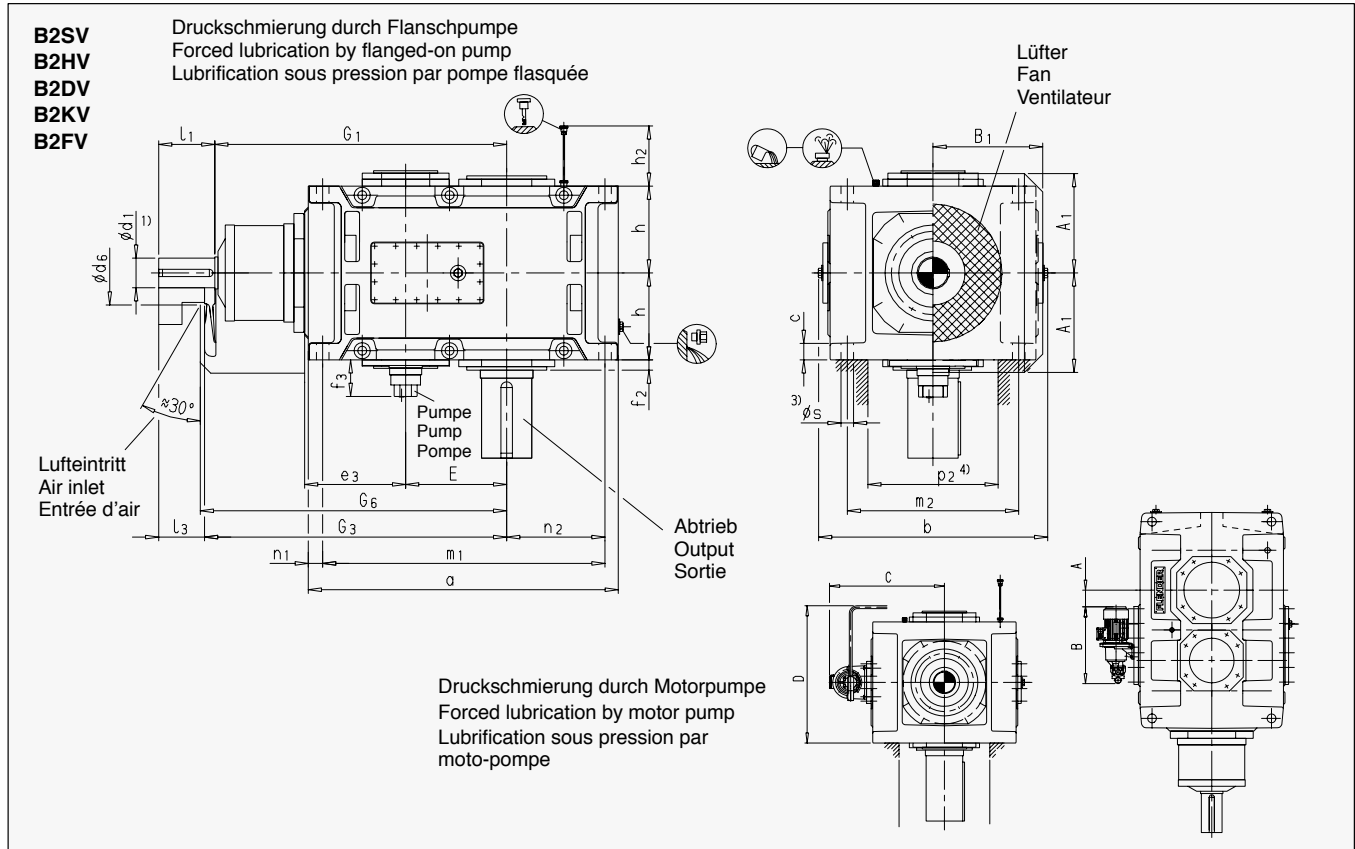

Größe Size Taille	Antrieb / Input / Entrée										Lüfter / Fan / Ventilateur		
	$i_N = 5 - 11.2$			$i_N = 5.6 - 11.2$			$G_1$	$G_3$	$G_1$	$G_3$			
	$i_N = 6.3 - 14$			$i_N = 5.6 - 12.5$									
	$i_N = 7.1 - 12.5$												
$d_1$	$l_1$	$l_3$	$d_1$	$l_1$	$l_3$	$G_1$	$G_3$	$G_1$	$G_3$	$A_1$	$B_1$	$d_6$	
13 + 14	110	205	165				1070	1110	1140	1180	375	450	245
15	130	245	200				1277	1322			435	495	280
16				130	245	200			1323	1368	435	495	280
17				150	245	200	1435	1480			505	555	380
18	150	245	200				1495	1540			505	555	380

Größe Size Taille	Zahnradgetriebe / Gear units / Réducteurs à engrenages									
	b	c	$e_3$	h	$h_2$	$m_2$	$n_1$	$p_2$	s	
13 + 14	900	$61 \pm 2$	380	325	350	680	50	500	48	
15 + 16	980	$72 \pm 2$	450	380	430	750	60	570	55	
17 + 18	1110	$81 \pm 2$	510	437.5	480	840	70	630	65	

Größe Size Taille	Zahnradgetriebe / Gear units / Réducteurs à engrenages										
	a	E	$f_2$	$G_6$	$m_1$	$n_2$	Pumpe Pump Pompe $f_3$	Motorpumpe / Motor pump Moto-pompe			
								A +)	B +)	C +)	D +)
13	1130	370	38	1130	1035	360	200	-110	490	680	810
14	1270	440	45	1200	1175	430	200	-40	490	680	810
15	1350	442	75	1340	1235	430	200	0	490	730	920
16	1440	488	75	1385	1325	475	200	45	490	730	920
17	1490	490	98	1500	1360	465	200	-20	490	780	1030
18	1610	550	98	1560	1480	525	200	40	490	780	1030

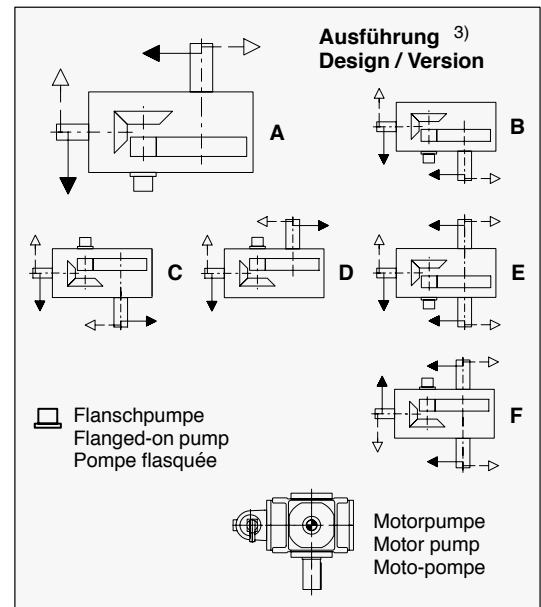

+ ) max. Abmessungen; Einzelheiten nach auftragsbezogener Dokumentation.

+ ) Max. dimensions; details acc. to order-related documentation.

+ ) Dimensions maximales; détails selon documentation relative à la commande.



# Zahnradgetriebe

Zweistufig  
Vertikal  
Bauart B2.V  
Größen 13 - 18

# Gear Units

Two Stage  
Vertical  
Type B2.V  
Sizes 13 - 18

# Réducteurs à engrenages

à deux trains  
Vertical  
Type B2.V  
Tailles 13 - 18

## Abtrieb / Output / Sortie

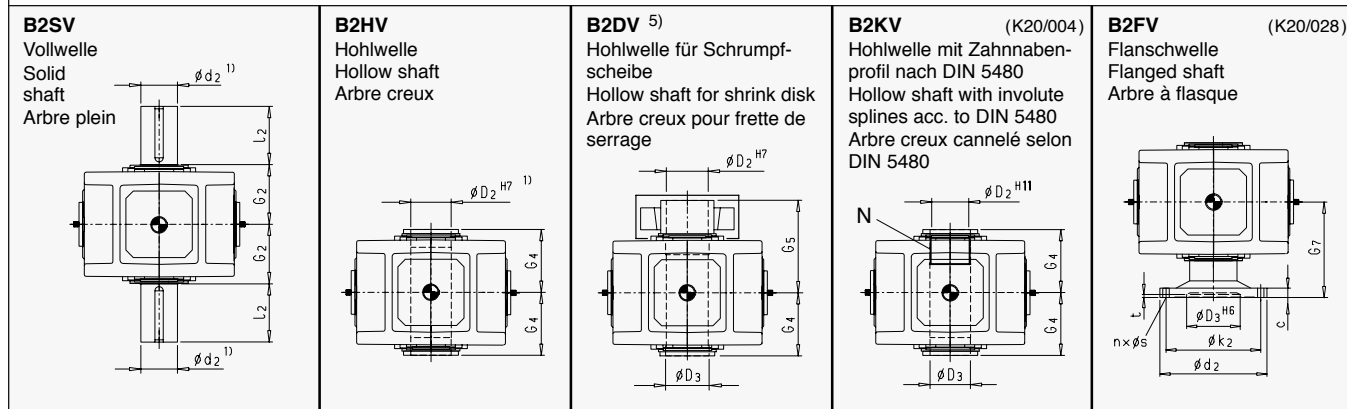

Größe Size Taille	B2SV			B2HV		B2DV				B2KV				B2FV						
	d <sub>2</sub>	l <sub>2</sub>	G <sub>2</sub>	D <sub>2</sub>	G <sub>4</sub>	D <sub>2</sub>	D <sub>3</sub>	G <sub>4</sub>	G <sub>5</sub>	N / DIN 5480	D <sub>2</sub>	D <sub>3</sub>	G <sub>4</sub>	c	d <sub>2</sub>	D <sub>3</sub>	k <sub>2</sub>	n x s	t	G <sub>7</sub>
13	200	350	390	-	-	-	-	-	-	-	-	-	-	48	580	310	500	20 x 33	14	525
14	210	350	390	210	390	210	215	390	535	N 190x5x30x36x9H	180	215	390	48	620	310	540	24 x 33	14	525
15	230	410	460	-	-	-	-	-	-	-	-	-	-	55	710	360	630	28 x 33	17	625
16	240	410	460	240	450	240	245	450	620	N 220x5x30x42x9H	210	245	450	55	740	360	660	30 x 33	17	625
17	250	410	540	-	-	-	-	-	-	-	-	-	-	60	750	410	660	24 x 39	18	695
18	270	470	540	275	510	280	285	510	700	N 250x5x30x48x9H	240	285	510	60	800	410	710	26 x 39	18	695

Größe Size Taille	Ölmenge Oil quantity Quantité de huile (l) *)	Gewicht Weight / Poids (kg) **) **)	
		B2SV B2HV B2DV B2KV	B2FV
13	125	2350	2520
14	140	2725	2905
15	190	3795	4050
16	200	4160	4430
17	270	5320	5640
18	295	5860	6230

**Kühlschlange / Cooling coil  
Serpentin de refroidissement** <sup>3)</sup>

Wasseranschluß für Kühlschlange G1/2"  
Water connection for cooling coil G1/2"  
Adduction pour serpentin de refroidissement G1/2"

Abtrieb  
Output  
Sortie

Größe Size Taille	m <sub>10</sub>	n <sub>10</sub>	e <sub>12</sub>	l/(min x)
13	324	300	335	8
14	324	300	405	8
15	396	345	390	8
16	396	345	435	8
17	324	395	425	8
18	324	395	485	8

Kühlschlange geeignet für Süß-, See- und Brackwasser  
Cooling coil suitable for fresh, sea and brackish water  
Serpentin de refroidissement adapté à l'eau douce, de mer et saumâtre

x) Erforderliche Kühlwassermenge, max. Kühlwasserdruck: 8 bar  
Cooling water quantity required; max. cooling water pressure: 8 bar  
Quantité d'eau de refroidissement nécessaire, pression maxi de l'eau de refroidissement: 8 bar

Abmessungen in mm

- Wellen:**
  - n<sub>6</sub> > Ø 100
  - Paßfedernut nach DIN 6885/1, Nabennutbreite nach ISO JS9
  - Paßfeder nach DIN 6885/1 Form B
  - Einzelheiten siehe Seiten 126 - 135
- Kühlschlange:**
  - Ausführungen C, D und F mit Druckschmierung durch Flanscpumpe nicht möglich.
  - Kombination mit Druckschmierung durch Motorpumpe auf Anfrage.
- Freiraum für Pumpe, Rohre und Deckel, genaue Maße ggf. anfragen.
- Ausführungen A und D bei Hohlwellenge triebe auf Anfrage.
- Richtwerte; genaue Angaben nach auftragsbezogener Dokumentation.
- ohne Ölfüllung

Dimensions in mm

- Shafts:**
  - n<sub>6</sub> > Ø 100
  - Keyway acc. to DIN 6885/1, Hub keyway width acc. to ISO JS9
  - Parallel key acc. to DIN 6885/1 form B
  - For details, see pages 126 - 135
- Cooling coil:**
  - For C, D and F designs, forced lubrication by flanged-on pump not possible.
  - Combination with forced lubrication by motor pump on request.
- Space for pump, pipes and cover; for exact dimensions, please refer to us.
- A and D designs for gear units with hollow shaft on request.
- Approximate values; exact data acc. to order-related documentation.
- Without oil filling

Dimensions en mm

- Arbres:**
  - n<sub>6</sub> > Ø 100
  - Rainure de clavette selon DIN 6885/1, Tolérance dans le moyeu selon ISO JS9
  - Clavette selon DIN 6885/1 forme B
  - Détails voir pages 126 - 135
- Serpentin de refroidissement:**
  - Impossibilité de livrer les exécutions C, D et F avec une lubrification sous pression par pompe attelée.
  - Combinaison avec lubrification sous pression par moto-pompe sur demande.
- Espace libre pour passage pompe, tuyauterie et couvercle, côtes précises sur demande.
- Exécutions A et D pour réducteurs à arbre creux sur demande.
- Valeurs approximatives; données exactes selon documentation relative à la commande.
- sans huile



# Zahnradgetriebe

Dreistufig  
Vertikal  
Bauart B3.V  
Größen 4 - 12

# Gear Units

Three Stage  
Vertical  
Type B3.V  
Sizes 4 - 12

# Réducteurs à engrenages

à trois trains  
Vertical  
Type B3.V  
Tailles 4 - 12

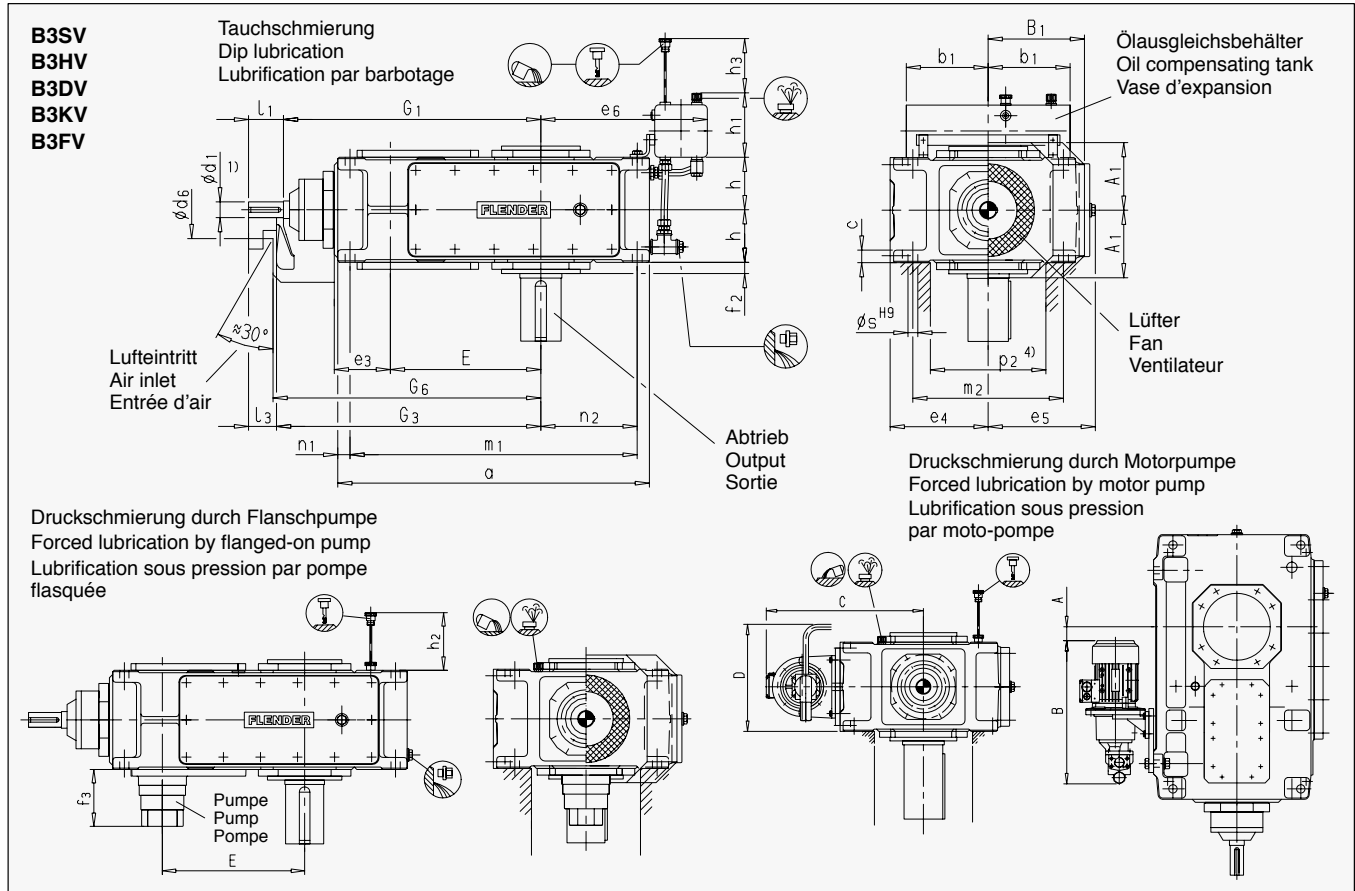

4

Größe Size Taille	Antrieb / Input / Entrée										Lüfter / Fan / Ventilateur		
	$i_N = 12.5 - 45$			$i_N = 50 - 71$			$G_1$	$G_3$	$G_1$	$G_3$			
	$d_1$	$l_1$	$l_3$	$d_1$	$l_1$	$l_3$							
4	30	70	50	25	60	40	500	520	-	-	143	200	110
5 + 6	35	80	60	28	60	40	575	595	610	630	168	235	130
7 + 8	45	100	80	35	80	60	690	710	735	755	193	275	165
9 + 10	55	110	80	40	100	70	800	830	850	880	231	325	175
11 + 12	70	135	105	50	110	80	960	990	1030	1060	263	385	190

Größe Size Taille	Zahnradgetriebe / Gear units / Réducteurs à engrenages											
	$b_1$	$c$	$e_3$	$e_4$	$h$	$h_1$	$h_2$	$h_3$	$m_2$	$n_1$	$p_2$	$s$
4	150	$30 \pm 1$	110	200	107.5	165	-	180	300	30	220	24
5 + 6	240	$30 \pm 1$	130	230	127.5	205	180	240	360	30	270	24
7 + 8	240	$36 \pm 1$	160	280	150	205	165	250	430	35	330	28
9 + 10	330	$45 \pm 1.5$	185	320	185	275	205	330	490	40	370	36
11 + 12	330	$54 \pm 1.5$	225	380	215	275	240	340	600	50	440	40

Größe Size Taille	Zahnradgetriebe / Gear units / Réducteurs à engrenages												
	$a$	$e_5$	$e_6$	$E$	$f_2$	$G_6$	$m_1$	$n_2$	Pumpe Pump Pompe $f_3$	Motorpumpe / Motor pump / Moto-pompe A+) B+) C+) D+)			
4	565	215	320	270	22	530	505	160	-	-	-	-	-
5	640	252	385	315	28	605	580	175	190	-85	490	480	390
6	720	252	425	350	28	640	660	220	190	-50	490	480	390
7	785	292	425	385	30	720	715	215	190	0	490	530	420
8	890	302	485	430	32	765	820	275	190	45	490	530	420
9	925	342	560	450	32	845	845	260	180	-80	490	570	490
10	1025	342	610	500	32	895	945	310	180	-30	490	570	490
11	1105	402	595	545	35	1010	1005	295	180	-15	490	630	570
12	1260	410	680	615	35	1080	1160	380	180	55	490	630	570

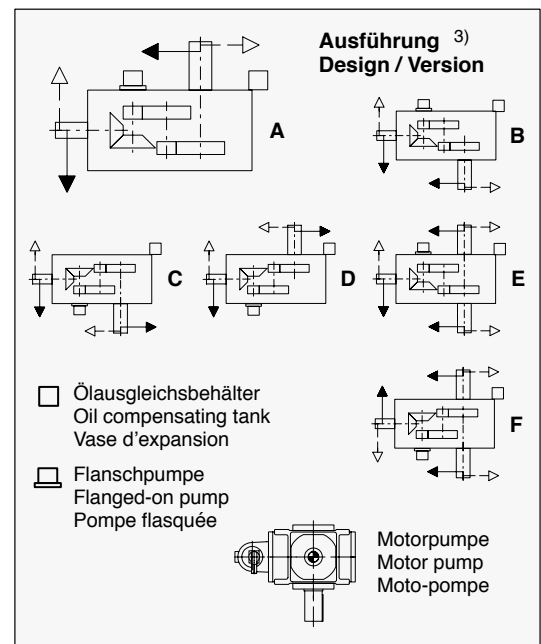

+) max. Abmessungen; Einzelheiten nach auftragsbezogener Dokumentation.

+) Max. dimensions; details acc. to order-related documentation.

+) Dimensions maximales; détails selon documentation relative à la commande.

# Zahnradgetriebe

Dreistufig  
Vertikal  
Bauart B3.V  
Größen 4 - 12

# Gear Units

Three Stage  
Vertical  
Type B3.V  
Sizes 4 - 12

# Réducteurs à engrenages

à trois trains  
Vertical  
Type B3.V  
Tailles 4 - 12

## Abtrieb / Output / Sortie

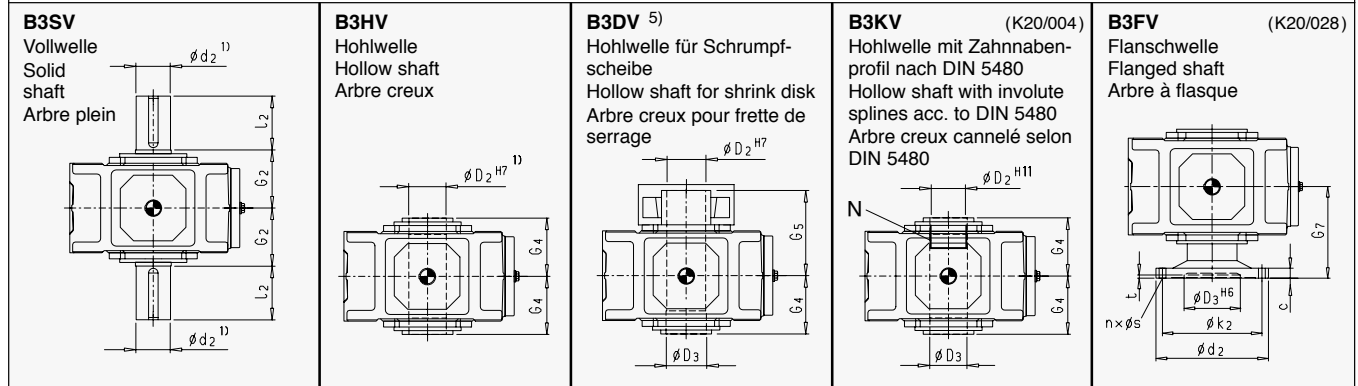

Größe Size Taille	B3SV			B3HV		B3DV				B3KV				B3FV									
	d <sub>2</sub>	l <sub>2</sub>	G <sub>2</sub>	D <sub>2</sub>	G <sub>4</sub>	D <sub>2</sub>	D <sub>3</sub>	G <sub>4</sub>	G <sub>5</sub>	N / DIN 5480				D <sub>2</sub>	D <sub>3</sub>	G <sub>4</sub>	c	d <sub>2</sub>	D <sub>3</sub>	k <sub>2</sub>	n x s	t	G <sub>7</sub>
4	80	170	140	80	140	85	85	140	205	-	-	-	-	-	-	-	-	-	-	-	-	-	-
5	100	210	165	95	165	100	100	165	240	N 95x3x30x30x9H	89	100	165	25	300	150	260	16 x 22	10	255			
6	110	210	165	105	165	110	110	165	240	N 95x3x30x30x9H	89	110	165	25	320	160	280	18 x 22	10	255			
7	120	210	195	115	195	120	120	195	280	N 120x3x30x38x9H	114	120	195	30	370	180	320	16 x 26	10	300			
8	130	250	195	125	195	130	130	195	285	N 120x3x30x38x9H	114	130	195	30	390	190	340	18 x 26	10	300			
9	140	250	235	135	235	140	145	235	330	N 140x3x30x45x9H	134	145	235	38	430	220	380	20 x 26	12	350			
10	160	300	235	150	235	150	155	235	350	N 140x3x30x45x9H	134	155	235	38	470	240	420	22 x 26	12	350			
11	170	300	270	165	270	165	170	270	400	N 170x5x30x32x9H	160	170	270	42	510	260	450	18 x 33	12	400			
12	180	300	270	180	270	180	185	270	405	N 170x5x30x32x9H	160	185	270	42	540	280	480	22 x 33	12	400			

Größe Size Taille	Ölmenge / Oil quantity Quantité de huile (l) *)		Gewicht / Weight Poids (kg) *) **)		Kühlschlange / Cooling coil Serpentin de refroidissement 3)	Größe Size Taille			
	Tauchs- schmierung Dip lubrication Lubrification par barbotage	Druck- schmierung Forced lubrication Lubrification sous pression	B3SV B3HV B3DV B3KV	B3FV		m <sub>10</sub>	n <sub>10</sub>	e <sub>12</sub>	l/(min x)
4	20	-	210	-	Wasseranschluß für Kühlschlange G1/2" Water connection for cooling coil G1/2" Adduction pour serpentin de refroidissement G1/2"	34	140	155	4
5	34	17	325	360		68	168	170	4
6	36	18	380	420	Abtrieb Output Sortie	70	162	215	4
7	60	30	550	600		100	197	210	4
8	68	34	635	690	Kühlschlange geeignet für Süß-, See- und Brackwasser Cooling coil suitable for fresh, sea and brackish water Serpentin de refroidissement adapté à l'eau douce, de mer et saumâtre	100	197	270	4
9	96	48	890	975	x) Erforderliche Kühlwassermenge, max. Kühlwasserdruck: 8 bar / Cooling water quantity required; max. cooling water pressure: 8 bar / Quantité d'eau de refroidissement nécessaire, pression maxi de l'eau de refroidissement: 8 bar	140	210	245	8
10	105	52	1020	1110		100	225	295	8
11	155	77	1455	1585		110	285	275	8
12	175	87	1730	1870		200	271	360	8

### Abmessungen in mm

- Wellen:**
    - k<sub>6</sub> = Ø 25; Ø 28 ≥ m<sub>6</sub> ≤ Ø 100; n<sub>6</sub> > Ø 100
    - Paßfedern nach DIN 6885/1, Nabennutbreite nach ISO JS9
    - Paßfeder nach DIN 6885/1 Form B
    - Einzelheiten siehe Seiten 126 - 135
  - Kühlschlange:**
    - Ausführungen A, B und E mit Druckschmierung durch Flanscpumpe nicht möglich.
    - Kombination mit Druckschmierung durch Motorpumpe auf Anfrage.
  - Freiraum für Pumpe, Rohre und Deckel, genaue Maße ggf. anfragen.
  - Ausführungen A und D bei Hohlwellengetriebe auf Anfrage.
- \*) Richtwerte; genaue Angaben nach auftragsbezogener Dokumentation.  
\*\*) ohne Ölfüllung

### Dimensions in mm

- Shafts:**
    - k<sub>6</sub> = Ø 25; Ø 28 ≥ m<sub>6</sub> ≤ Ø 100; n<sub>6</sub> > Ø 100
    - Keyway acc. to DIN 6885/1, Hub keyway width acc. to ISO JS9
    - Parallel key acc. to DIN 6885/1 form B
    - For details, see pages 126 - 135
  - Cooling coil:**
    - For A, B and E designs, forced lubrication by flanged-on pump not possible.
    - Combination with forced lubrication by motor pump on request.
  - Space for pump, pipes and cover; for exact dimensions, please refer to us.
  - A and D designs for gear units with hollow shaft on request.
- \*) Approximate values; exact data acc. to order-related documentation.  
\*\*) Without oil filling

### Dimensions en mm

- Arbres:**
    - k<sub>6</sub> = Ø 25; Ø 28 ≥ m<sub>6</sub> ≤ Ø 100; n<sub>6</sub> > Ø 100
    - Rainure de clavette selon DIN 6885/1, Tolérance dans le moyeu selon ISO JS9
    - Clavette selon DIN 6885/1 forme B
    - Détails voir pages 126 - 135
  - Serpentin de refroidissement:**
    - Impossibilité de livrer les exécutions A, B et E avec une lubrification sous pression par pompe attelée.
    - Combinaison avec lubrification sous pression par moto-pompe sur demande.
  - Espace libre pour passage pompe, tuyauterie et couvercle, côtes précises sur demande.
  - Exécutions A et D pour réducteurs avec arbre creux sur demande.
- \*) Valeurs approximatives; données exactes selon documentation relative à la commande.  
\*\*) sans huile

# Zahnradgetriebe

Dreistufig  
Vertikal  
Bauart B3.V  
Größen 13 - 22

# Gear Units

Three Stage  
Vertical  
Type B3.V  
Sizes 13- 22

# Réducteurs à engrenages

à trois trains  
Vertical  
Type B3.V  
Tailles 13 - 22

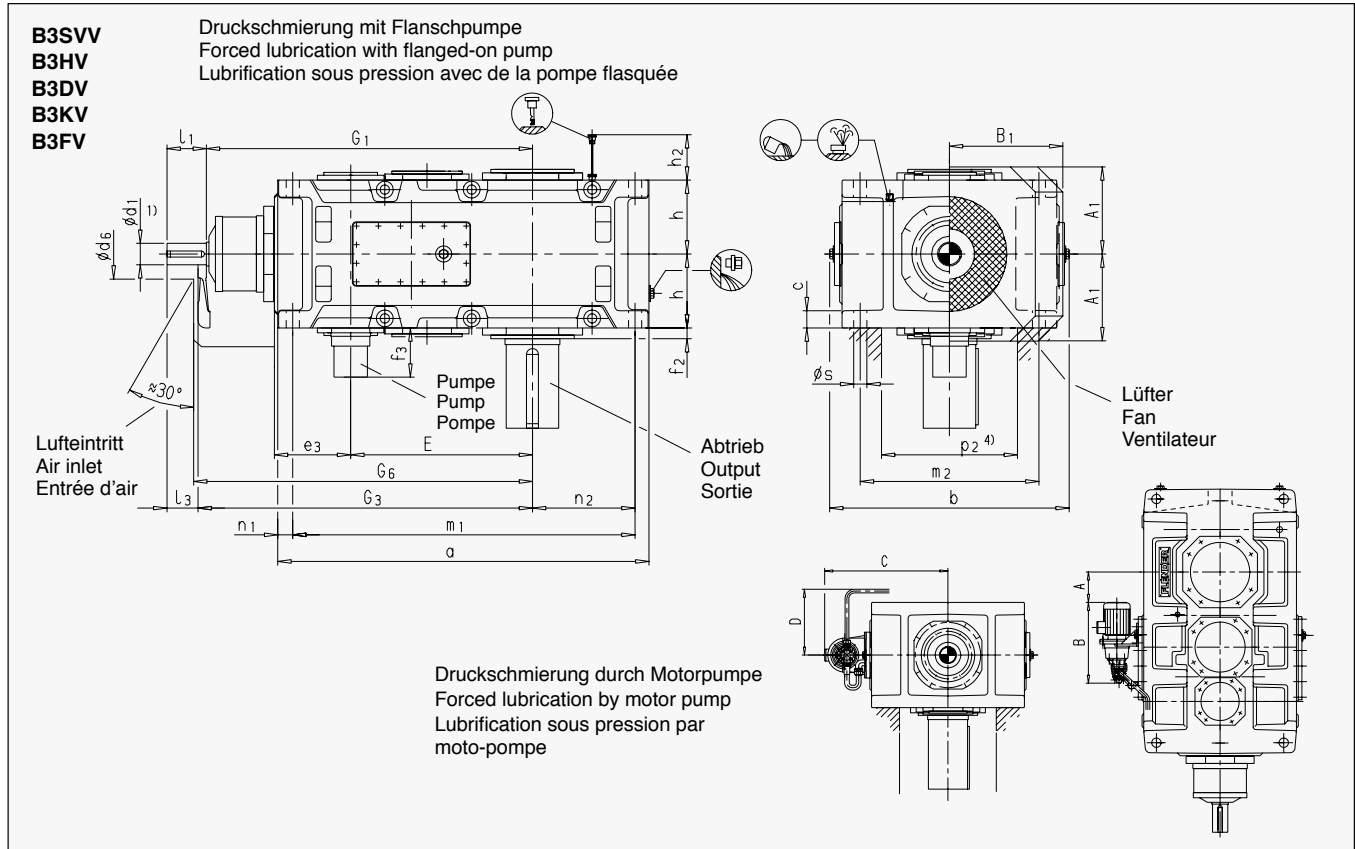

Größe Size Taille	Antrieb / Input / Entrée						Lüfter / Fan / Ventilateur						
	$i_N = 12.5 - 45$			$i_N = 50 - 71$			$G_1$	$G_3$	$G_1$	$G_3$	$A_1$	$B_1$	$d_6$
	$i_N = 14 - 50$			$i_N = 56 - 80$									
	$i_N = 16 - 56$			$i_N = 63 - 90$									
$d_1$	$l_1$	$l_3$	$d_1$	$l_1$	$l_3$	$A_1$	$B_1$	$d_6$					
13 + 14	80	165	130	60	140	105	1125	1160	1195	1230	325	475	210
15 + 16	90	165	130	70	140	105	1367	1402	1413	1448	365	520	210
17 + 18	110	205	165	80	170	130	1560	1600	1620	1660	395	570	230
19 + 20	Auf Anfrage / On request / Sur demande												
21 + 22	Auf Anfrage / On request / Sur demande												

Größe Size Taille	Zahnradgetriebe / Gear units / Réducteurs à engrenages									
	b	c	$e_3$	$f_2$	h	$h_2$	$m_2$	$n_1$	$p_2$	s
13 + 14	900	$61 \pm 2$	265	35	272.5	300	680	50	500	48
15 + 16	980	$72 \pm 2$	320	42	310	340	750	60	570	55
17 + 18	1110	$81 \pm 2$	370	42	340	380	850	70	630	55
19 + 20	Auf Anfrage / On request / Sur demande									
21 + 22	Auf Anfrage / On request / Sur demande									

Größe Size Taille	Zahnradgetriebe / Gear units / Réducteurs à engrenages									
	a	E	$G_6$	$m_1$	$n_2$	Motorpumpe / Motor pump Moto-pompe				
						$f_3$	A +)	B +)	C +)	D +)
13	1290	635	1180	1195	360	170	5	580	690	760
14	1430	705	1250	1335	430	170	75	580	690	760
15	1550	762	1420	1435	430	170	110	580	730	850
16	1640	808	1470	1525	475	170	160	580	730	850
17	1740	860	1620	1610	465	170	160	580	790	930
18	1860	920	1680	1730	525	170	220	580	790	930
19 + 20	Auf Anfrage / On request / Sur demande									
21 + 22	Auf Anfrage / On request / Sur demande									

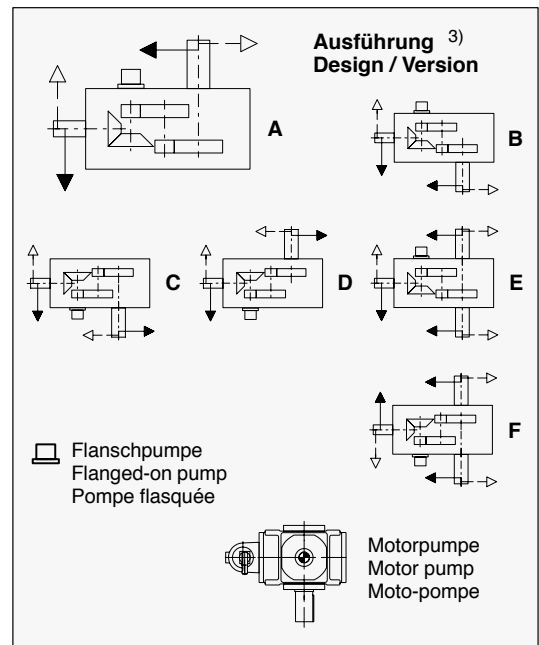

+ ) max. Abmessungen; Einzelheiten nach auftragsbezogener Dokumentation.

+ ) Max. dimensions; details acc. to order-related documentation.

+ ) Dimensions maximales; détails selon documentation relative à la commande.

# Zahnradgetriebe

Dreistufig  
Vertikal  
Bauart B3.V  
Größen 13 - 22

# Gear Units

Three Stage  
Vertical  
Type B3.V  
Sizes 13 - 22

# Réducteurs à engrenages

à trois trains  
Vertical  
Type B3.V  
Tailles 13 - 22

## Abtrieb / Output / Sortie

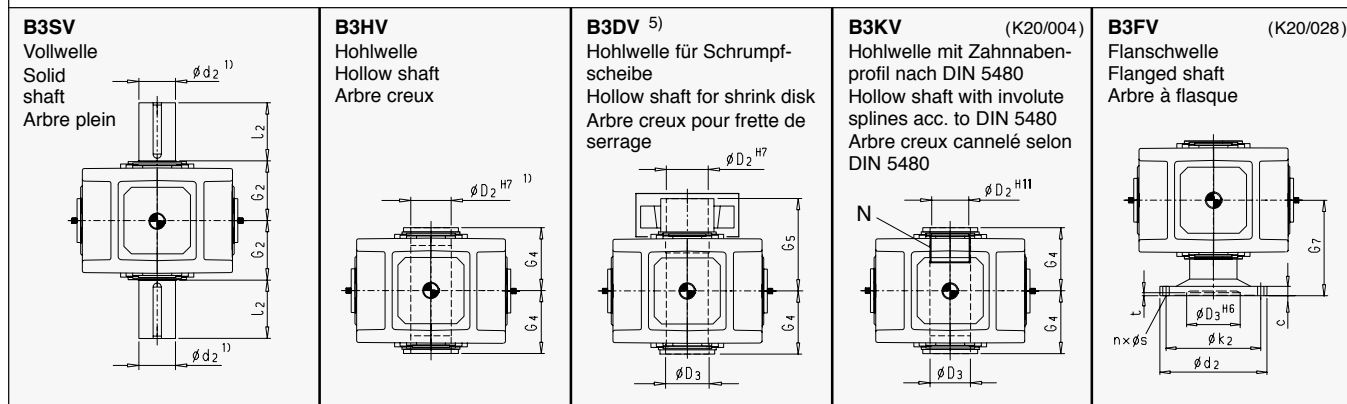

Größe Size Taille	B3SV			B3HV		B3DV				B3KV					B3FV						
	d <sub>2</sub>	l <sub>2</sub>	G <sub>2</sub>	D <sub>2</sub>	G <sub>4</sub>	D <sub>2</sub>	D <sub>3</sub>	G <sub>4</sub>	G <sub>5</sub>	N / DIN 5480	D <sub>2</sub>	D <sub>3</sub>	G <sub>4</sub>	c	d <sub>2</sub>	D <sub>3</sub>	k <sub>2</sub>	n x s	t	G <sub>7</sub>	
13	200	350	335	190	335	190	195	335	480	N 190x5x30x36x9H	180	195	335	48	580	310	500	20 x 33	14	480	
14	210	350	335	210	335	210	215	335	480	N 190x5x30x36x9H	180	215	335	48	620	310	540	24 x 33	14	480	
15	230	410	380	230	380	230	235	380	550	N 220x5x30x42x9H	210	235	380	55	710	360	630	28 x 33	17	550	
16	240	410	380	240	380	240	245	380	550	N 220x5x30x42x9H	210	245	380	55	740	360	660	30 x 33	17	550	
17	250	410	415	250	415	250	260	415	600	N 250x5x30x48x9H	240	260	415	60	750	410	660	24 x 39	18	600	
18	270	470	415	275	415	280	285	415	600	N 250x5x30x48x9H	240	285	415	60	800	410	710	26 x 39	18	600	
19 - 22	Auf Anfrage / On request / Sur demande																				

Größe Size Taille	Ölmenge Oil quantity Quantité de huile (l) *)	Gewicht Weight / Poids (kg) **)	
		B3SV B3HV B3DV B3KV	B3FV
13	115	2260	2420
14	130	2615	2785
15	180	3540	3780
16	190	3765	4020
17	260	4760	5060
18	275	5240	5590
19 - 22	Auf Anfrage / On request Sur demande		

**Kühlschlange / Cooling coil  
Serpentin de refroidissement** <sup>3)</sup>

Wasseranschluß für Kühlschlange G1/2"  
Water connection for cooling coil G1/2"  
Adduction pour serpentin de refroidissement G1/2"

Abtrieb  
Output  
Sortie

Kühlschlange geeignet für Süß-, See- und Brackwasser  
Cooling coil suitable for fresh, sea and brackish water  
Serpentin de refroidissement adapté à l'eau douce, de mer et saumâtre

Größe Size Taille	m <sub>10</sub>	n <sub>10</sub>	e <sub>12</sub>	l/(min x)
13	252	300	335	8
14	252	300	405	8
15	290	335	395	8
16	290	335	440	8
17	340	380	425	8
18	340	380	485	8
19 - 22	Auf Anfrage On request Sur demande			

x) Erforderliche Kühlwassermenge, max. Kühlwasserdruck: 8 bar  
Cooling water quantity required; max. cooling water pressure: 8 bar  
Quantité d'eau de refroidissement nécessaire, pression maxi de l'eau de refroidissement: 8 bar

### Abmessungen in mm

#### 1) Wellen:

- m<sub>6</sub> <= Ø 100; n<sub>6</sub> > Ø 100
- Paßfedernut nach DIN 6885/1, Nabennutbreite nach ISO JS9
- Paßfeder nach DIN 6885/1 Form B
- Einzelheiten siehe Seiten 126 - 135

#### 3) Kühlschlange:

- Ausführungen A, B und E mit Druckschmierung durch Flanscpumpe nicht möglich.
- Kombination mit Druckschmierung durch Motorpumpe auf Anfrage.

4) Freiraum für Pumpe, Rohre und Deckel, genaue Maße ggf. anfragen.

5) Ausführungen A und D bei Hohlwellengetriebe auf Anfrage.

\*) Richtwerte; genaue Angaben nach auftragsbezogener Dokumentation.

\*\*) ohne Ölfüllung

### Dimensions in mm

#### 1) Shafts:

- m<sub>6</sub> <= Ø 100; n<sub>6</sub> > Ø 100
- Keyway acc. to DIN 6885/1, Hub keyway width acc. to ISO JS9
- Parallel key acc. to DIN 6885/1 form B
- For details, see pages 126 - 135

#### 3) Cooling coil:

- For A, B and E designs, forced lubrication by flanged-on pump not possible.
- Combination with forced lubrication by motor pump on request.

4) Space for pump, pipes and cover; for exact dimensions, please refer to us.

5) A and D designs for gear units with hollow shaft on request.

\*) Approximate values; exact data acc. to order-related documentation.

\*\*) Without oil filling

### Dimensions en mm

#### 1) Arbres:

- m<sub>6</sub> <= Ø 100; n<sub>6</sub> > Ø 100
- Rainure de clavette selon DIN 6885/1, Tolérance dans le moyeu selon ISO JS9
- Clavette selon DIN 6885/1 forme B
- Détails voir pages 126 - 135

#### 3) Serpentin de refroidissement:

- Impossibilité de livrer les exécutions A, B et E avec une lubrification sous pression par pompe attelée.
- Combinaison avec lubrification sous pression par moto-pompe sur demande.

4) Espace libre pour passage pompe, tuyauterie et couvercle, côtes précises sur demande.

5) Exécutions A et D pour réducteurs avec arbre creux sur demande.

\*) Valeurs approximatives; données exactes selon documentation relative à la commande.

\*\*) sans huile



# Zahnradgetriebe

Vierstufig  
Vertikal  
Bauart B4.V  
Größen 5 - 12

# Gear Units

Four Stage  
Vertical  
Type B4.V  
Sizes 5 - 12

# Réducteurs à engrenages

à quatre trains  
Vertical  
Type B4.V  
Tailles 5 - 12

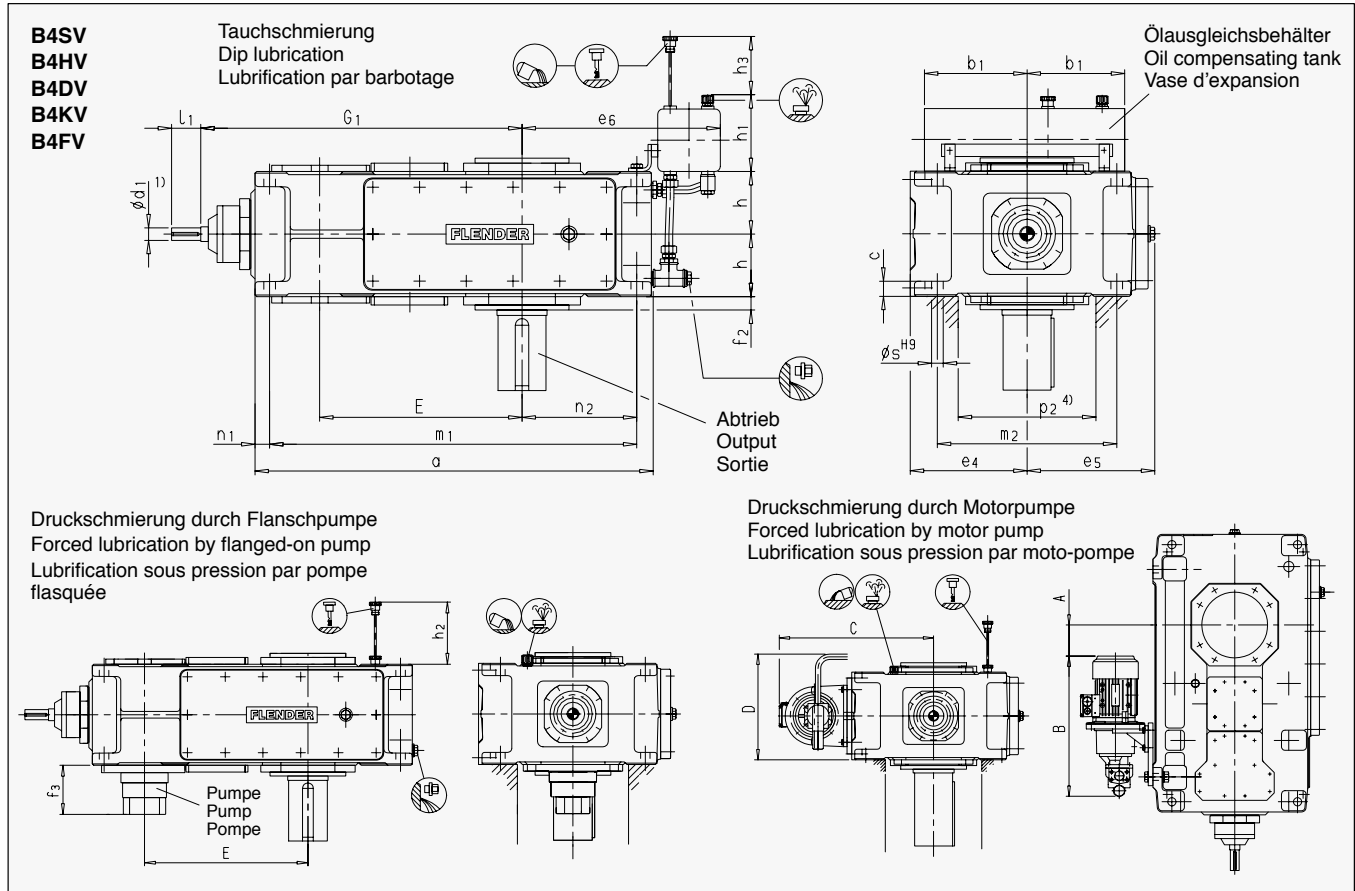

4

Größe Size Taille	Antrieb / Input / Entrée					
	$i_N = 80 - 180$			$i_N = 200 - 315$		
	$d_1$	$l_1$	$d_1$	$l_1$	$G_1$	$G_1$
5 + 6	28	55	20	50	615	650
7 + 8	30	70	25	60	725	770
9 + 10	35	80	28	60	840	890
11 + 12	45	100	35	80	1010	1080

Größe Size Taille	Zahnradgetriebe / Gear units / Réducteurs à engrenages										
	$b_1$	$c_1$	$e_4$	$h$	$h_1$	$h_2$	$h_3$	$m_2$	$n_1$	$p_2$	$s$
5 + 6	240	$30 \pm 1$	230	127.5	205	190	240	360	30	270	24
7 + 8	240	$36 \pm 1$	280	150	205	165	250	430	35	330	28
9 + 10	330	$45 \pm 1.5$	320	185	275	205	330	490	40	370	36
11 + 12	330	$54 \pm 1.5$	380	215	275	240	340	600	50	440	40

Größe Size Taille	Zahnradgetriebe / Gear units / Réducteurs à engrenages												
	$a$	$e_5$	$e_6$	$E$	$f_2$	$m_1$	$n_2$	Pumpe Pump Pompe $f_3$	Motorpumpe / Motor pump / Moto-pompe				
									A +)	B +)	C +)	D +)	
5	690	252	385	405	28	630	175	200	-35	490	480	360	
6	770	252	425	440	28	710	220	200	0	490	480	360	
7	845	292	425	495	30	775	215	120	60	490	530	420	
8	950	302	485	540	32	880	275	120	105	490	530	420	
9	1000	342	560	580	32	920	260	120	-5	490	570	480	
10	1100	342	610	630	32	1020	310	120	45	490	570	480	
11	1200	402	595	705	35	1100	295	130	80	490	630	550	
12	1355	410	680	775	35	1255	380	130	150	490	630	550	

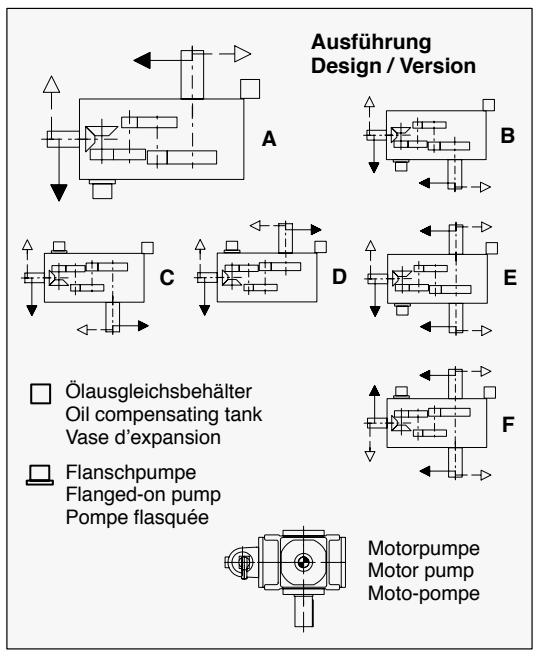

+ ) max. Abmessungen; Einzelheiten nach auftragsbezogener Dokumentation.

+ ) Max. dimensions; details acc. to order-related documentation.

+ ) Dimensions maximales; détails selon documentation relative à la commande.

# Zahnradgetriebe

Vierstufig  
Vertikal  
Bauart B4.V  
Größen 5 - 12

# Gear Units

Four Stage  
Vertical  
Type B4.V  
Sizes 5 - 12

# Réducteurs à engrenages

à quatre trains  
Vertical  
Type B4.V  
Tailles 5 - 12

## Abtrieb / Output / Sortie

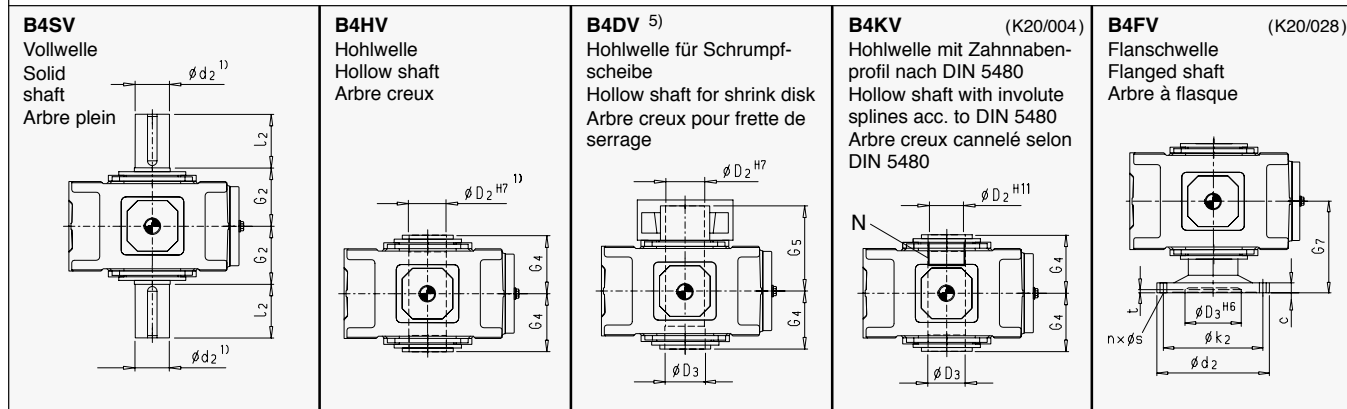

Größe Size Taille	B4SV			B4HV		B4DV				B4KV				B4FV						
	d <sub>2</sub>	l <sub>2</sub>	G <sub>2</sub>	D <sub>2</sub>	G <sub>4</sub>	D <sub>2</sub>	D <sub>3</sub>	G <sub>4</sub>	G <sub>5</sub>	N / DIN 5480	D <sub>2</sub>	D <sub>3</sub>	G <sub>4</sub>	c	d <sub>2</sub>	D <sub>3</sub>	k <sub>2</sub>	n x s	t	G <sub>7</sub>
5	100	210	165	95	165	100	100	165	240	N 95x3x30x30x9H	89	100	165	25	300	150	260	16 x 22	10	255
6	110	210	165	105	165	110	110	165	240	N 95x3x30x30x9H	89	110	165	25	320	160	280	18 x 22	10	255
7	120	210	195	115	195	120	120	195	280	N 120x3x30x38x9H	114	120	195	30	370	180	320	16 x 26	10	300
8	130	250	195	125	195	130	130	195	285	N 120x3x30x38x9H	114	130	195	30	390	190	340	18 x 26	10	300
9	140	250	235	135	235	140	145	235	330	N 140x3x30x45x9H	134	145	235	38	430	220	380	20 x 26	12	350
10	160	300	235	150	235	150	155	235	350	N 140x3x30x45x9H	134	155	235	38	470	240	420	22 x 26	12	350
11	170	300	270	165	270	165	170	270	400	N 170x5x30x32x9H	160	170	270	42	510	260	450	18 x 33	12	400
12	180	300	270	180	270	180	185	270	405	N 170x5x30x32x9H	160	185	270	42	540	280	480	22 x 33	12	400

Größe Size Taille	Ölmenge Oil quantity Quantité de huile (l) *)		Gewicht Weight / Poids (kg) *) **)	
	Tauchs- schmierung Dip lubrication Lubrification par barbotage	Druck- schmierung Forced lubrication Lubrification sous pression	B4SV B4HV B4DV B4KV	B4FV
5	36	18	335	370
6	40	20	385	425
7	65	32	555	605
8	73	36	655	710
9	105	52	890	975
10	110	55	1025	1115
11	175	87	1485	1615
12	200	100	1750	1890

### Abmessungen in mm

#### 1) Wellen:

- k<sub>6</sub> = Ø 25; Ø 28 ≥ m<sub>6</sub> ≤ Ø 100; n<sub>6</sub> > Ø 100
- Paßfedernut nach DIN 6885/1, Nabennutbreite nach ISO JS9
- Paßfeder nach DIN 6885/1 Form B
- Einzelheiten siehe Seiten 126 - 135

4) Freiraum für Pumpe, Rohre und Deckel, genaue Maße ggf. anfragen.

5) Ausführungen A und D bei Hohlwellenge-triebe auf Anfrage.

\*) Richtwerte; genaue Angaben nach auftrags-bezogener Dokumentation.

\*\*) ohne Ölfüllung

### Dimensions in mm

#### 1) Shafts:

- k<sub>6</sub> = Ø 25; Ø 28 ≥ m<sub>6</sub> ≤ Ø 100; n<sub>6</sub> > Ø 100
- Keyway acc. to DIN 6885/1, Hub keyway width acc. to ISO JS9
- Parallel key acc. to DIN 6885/1 form B
- For details, see pages 126 - 135

4) Space for pump, pipes and cover; for exact dimensions, please refer to us.

5) A and D designs for gear units with hollow shaft on request.

\*) Approximate values; exact data acc. to order-related documentation.

\*\*) Without oil filling

### Dimensions en mm

#### 1) Arbres:

- k<sub>6</sub> = Ø 25; Ø 28 ≥ m<sub>6</sub> ≤ Ø 100; n<sub>6</sub> > Ø 100
- Rainure de clavette selon DIN 6885/1, Tolérance dans le moyeu selon ISO JS9
- Clavette selon DIN 6885/1 forme B
- Détails voir pages 126 - 135

4) Espace libre pour passage pompe, tuyauterie et couvercle, côtes précises sur demande.

5) Exécutions A et D pour réducteurs à arbre creux sur demande.

\*) Valeurs approximatives; données exactes selon documentation relative à la commande.

\*\*) sans huile

# Zahnradgetriebe

Vierstufig  
Vertikal  
Bauart B4.V  
Größen 13 - 22

# Gear Units

Four Stage  
Vertical  
Type B4.V  
Sizes 13 - 22

# Réducteurs à engrenages

à quatre trains  
Vertical  
Type B4.HV  
Tailles 13 - 22

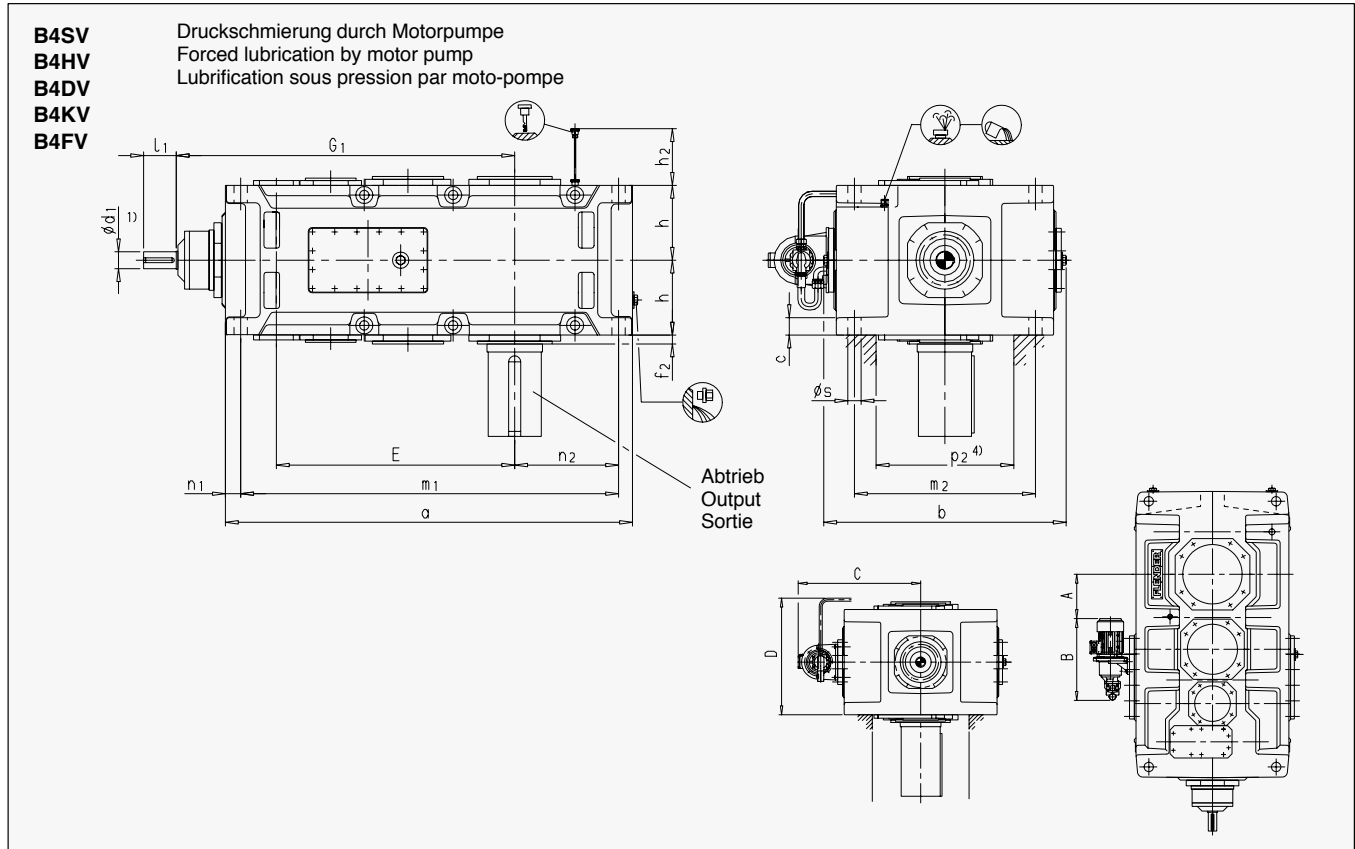

Größe Size Taille	Antrieb / Input / Entrée					
	$i_N = 80 - 180$		$i_N = 200 - 315$		$G_1$	$G_1$
	$i_N = 90 - 200$		$i_N = 224 - 355$			
	$i_N = 100 - 224$		$i_N = 250 - 400$			
	$d_1$	$l_1$	$d_1$	$l_1$		
13 + 14	55	110	40	100	1170	1240
15 + 16	70	135	50	110	1402	1448
17 + 18	70	135	50	110	1450	1510
19 + 20	Auf Anfrage / On request / Sur demande					
21 + 22	Auf Anfrage / On request / Sur demande					

Größe Size Taille	Zahnradgetriebe / Gear units / Réducteurs à engrenages							
	b	c	h	$h_2$	$m_2$	$n_1$	$p_2$	s
13 + 14	900	$61 \pm 2$	272.5	300	680	50	500	48
15 + 16	980	$72 \pm 2$	310	340	750	60	570	55
17 + 18	1110	$81 \pm 2$	340	374	850	70	630	55
19 + 20	Auf Anfrage / On request / Sur demande							
21 + 22	Auf Anfrage / On request / Sur demande							

Größe Size Taille	Zahnradgetriebe / Gear units / Réducteurs à engrenages									
	a	E	$f_2$	$m_1$	$n_2$	Motorpumpe / Motor pump Moto-pompe				
						A +)	B +)	C +)	D +)	
13	1395	820	35	1300	360	70	580	690	705	
14	1535	890	35	1440	430	140	580	690	705	
15	1680	987	42	1565	430	210	580	730	780	
16	1770	1033	42	1655	475	260	580	730	780	
17	1770	1035	42	1640	465	190	580	790	810	
18	1890	1095	42	1760	525	250	580	790	810	
19 + 20	Auf Anfrage / On request / Sur demande									
21 + 22	Auf Anfrage / On request / Sur demande									

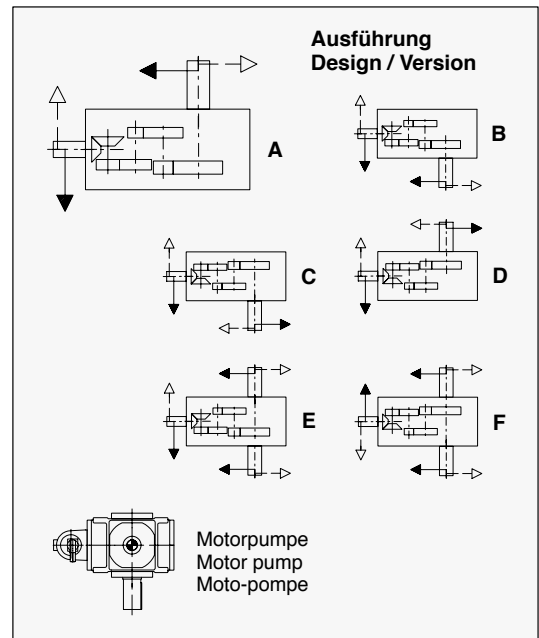

+ ) max. Abmessungen; Einzelheiten nach auftragsbezogener Dokumentation.

+ ) Max. dimensions; details acc. to order-related documentation.

+ ) Dimensions maximales; détails selon documentation relative à la commande.



# Zahnradgetriebe

Vierstufig  
Vertikal  
Bauart B4.V  
Größen 13 - 22

# Gear Units

Four Stage  
Vertical  
Type B4.V  
Sizes 13 - 22

# Réducteurs à engrenages

à quatre trains  
Vertical  
Type B4.V  
Tailles 13 - 22

## Abtrieb / Output / Sortie

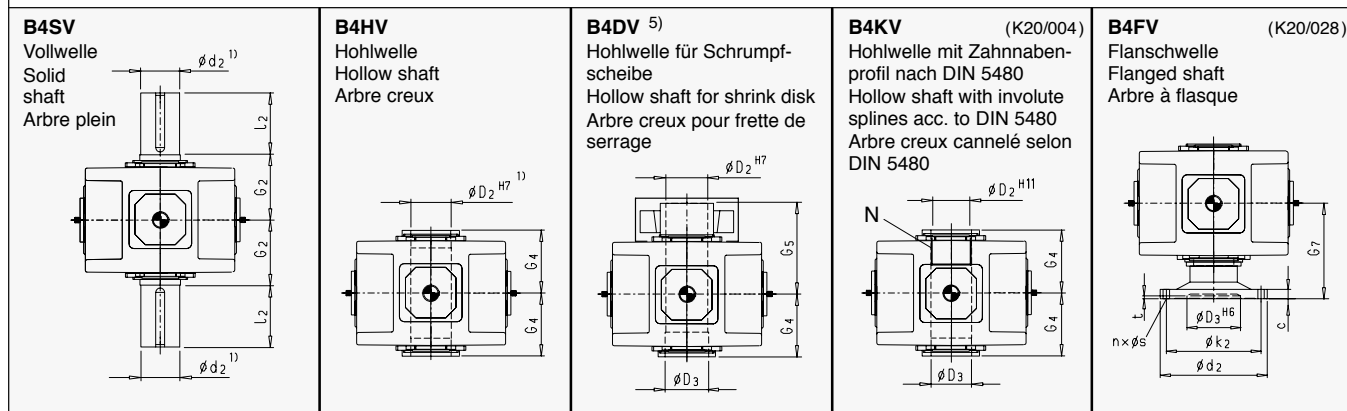

Größe Size Taille	B4SV			B4HV		B4DV				B4KV				B4FV						
	d <sub>2</sub>	l <sub>2</sub>	G <sub>2</sub>	D <sub>2</sub>	G <sub>4</sub>	D <sub>2</sub>	D <sub>3</sub>	G <sub>4</sub>	G <sub>5</sub>	N / DIN 5480	D <sub>2</sub>	D <sub>3</sub>	G <sub>4</sub>	c	d <sub>2</sub>	D <sub>3</sub>	k <sub>2</sub>	n x s	t	G <sub>7</sub>
13	200	350	335	190	335	190	195	335	480	N 190x5x30x36x9H	180	195	335	48	580	310	500	20 x 33	14	480
14	210	350	335	210	335	210	215	335	480	N 190x5x30x36x9H	180	215	335	48	620	310	540	24 x 33	14	480
15	230	410	380	230	380	230	235	380	550	N 220x5x30x42x9H	210	235	380	55	710	360	630	28 x 33	17	550
16	240	410	380	240	380	240	245	380	550	N 220x5x30x42x9H	210	245	380	55	740	360	660	30 x 33	17	550
17	250	410	415	250	415	250	260	415	600	N 250x5x30x48x9H	240	260	415	60	750	410	660	24 x 39	18	600
18	270	470	415	275	415	280	285	415	600	N 250x5x30x48x9H	240	285	415	60	800	410	710	26 x 39	18	600
19 - 22	Auf Anfrage / On request / Sur demande																			

Größe Size Taille	Ölmenge Oil quantity Quantité de huile (l) *)	Gewicht Weight / Poids (kg) **) **)	
		B4SV B4HV B4DV B4KV	B4FV
13	135	2280	2440
14	150	2605	2775
15	210	3435	3675
16	220	3765	4020
17	270	4460	4760
18	285	4930	5280
19 - 22	Auf Anfrage / On request Sur demande		

### Abmessungen in mm

#### 1) Wellen:

- m<sub>6</sub> ≤ Ø 100; n<sub>6</sub> > Ø 100
- Paßfedernut nach DIN 6885/1, Nabennutbreite nach ISO JS9
- Paßfeder nach DIN 6885/1 Form B
- Einzelheiten siehe Seiten 126 - 135

4) Freiraum für Pumpe, Rohre und Deckel, genaue Maße ggf. anfragen.

5) Ausführungen A und D bei Hohlwellenge triebe auf Anfrage.

\*) Richtwerte; genaue Angaben nach auftrags- bezogener Dokumentation.

\*\*) ohne Ölfüllung

### Dimensions in mm

#### 1) Shafts:

- m<sub>6</sub> ≤ Ø 100; n<sub>6</sub> > Ø 100
- Keyway acc. to DIN 6885/1, Hub keyway width acc. to ISO JS9
- Parallel key acc. to DIN 6885/1 form B
- For details, see pages 126 - 135

4) Space for pump, pipes and cover; for exact dimensions, please refer to us.

5) A and D designs for gear units with hollow shaft on request.

\*) Approximate values; exact data acc. to order-related documentation.

\*\*) Without oil filling

### Dimensions en mm

#### 1) Arbres:

- m<sub>6</sub> ≤ Ø 100; n<sub>6</sub> > Ø 100
- Rainure de clavette selon DIN 6885/1, Tolérance dans le moyeu selon ISO JS9
- Clavette selon DIN 6885/1 forme B
- Détails voir pages 126 - 135

4) Espace libre pour passage pompe, tuyauterie et couvercle, côtes précises sur demande.

5) Exécutions A et D pour réducteurs à arbre creux sur demande.

\*) Valeurs approximatives; données exactes selon documentation relative à la commande.

\*\*) sans huile



# Zahnradgetriebe

# Gear Units

# Réducteurs à engrenages

Zentrierbohrungen Form DS  
in Wellenenden DIN 332/1

Centre Holes, Form DS  
in Shaft Ends DIN 332/1

Centrage, forme DS  
dans bouts d'arbre DIN 332/1

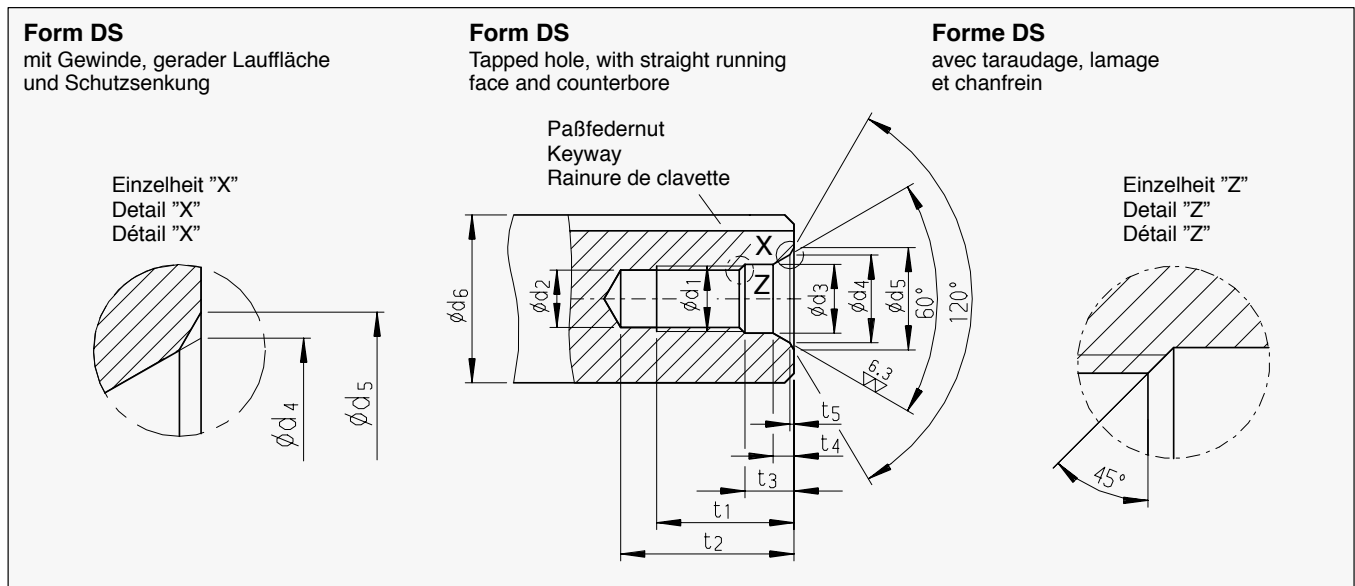

Empfohlene Durchmesserbereiche Recommended diameters Diamètres recommandés $d_6$ 1)		Form DS / Form DS / Forme DS												
über above de mm	bis to à mm	DS- Zentrierung Centering Centrage	$d_1$	$d_2$ 2)	$d_3$	$d_4$	$d_5$	$t_1$ +2	$t_2$ min.   max.	$t_3$ +1	$t_4$ ≈	$t_5$ ≈		
16	21	DS 6	M 6	5	6.4	9.6	10.5	16	20   22	5	2.8	0.4		
21	24	DS 8	M 8	6.8	8.4	12.2	13.2	19	25   28	6	3.3	0.4		
24	30	DS 10	M 10	8.5	10.5	14.9	16.3	22	30   34	7.5	3.8	0.6		
30	38	DS 12	M 12	10.2	13	18.1	19.8	28	37   42	9.5	4.4	0.7		
38	50	DS 16	M 16	14	17	23	25.3	36	45   50	12	5.2	1.0		
50	85	DS 20	M 20	17.5	21	28.4	31.3	42	53   59	15	6.4	1.3		
85	130	DS 24	M 24	21	25	34.2	38	50	63   68	18	8	1.6		
130 *	225 *	DS 30	M 30 *	26.5	31	44	48	60	77   83	17	11	1.9		
225 *	320 *	DS 36	M 36 *	32	37	55	60	74	93   99	22	15	2.3		
320 *	500 *	DS 42	M 42 *	37.5	43	65	71	84	105   111	26	19	2.7		

1) Durchmesser gilt für das fertige Werkstück

1) Diameter of the finished work piece

1) Diamètre de la pièce finie

2) Kernloch-Bohrerdurchmesser nach DIN 336 Teil 1

2) Drill diameters for tapping-size holes acc. to DIN 336 Pt. 1

2) Diamètre de perçage pour taraudage selon DIN 336 / 1

\*) Abmessungen nicht nach DIN 332

\*) Dimensions not acc. to DIN 332

\*) Dimensions non selon DIN 332

## Schutzhauben

## Guards

## Capot de protection

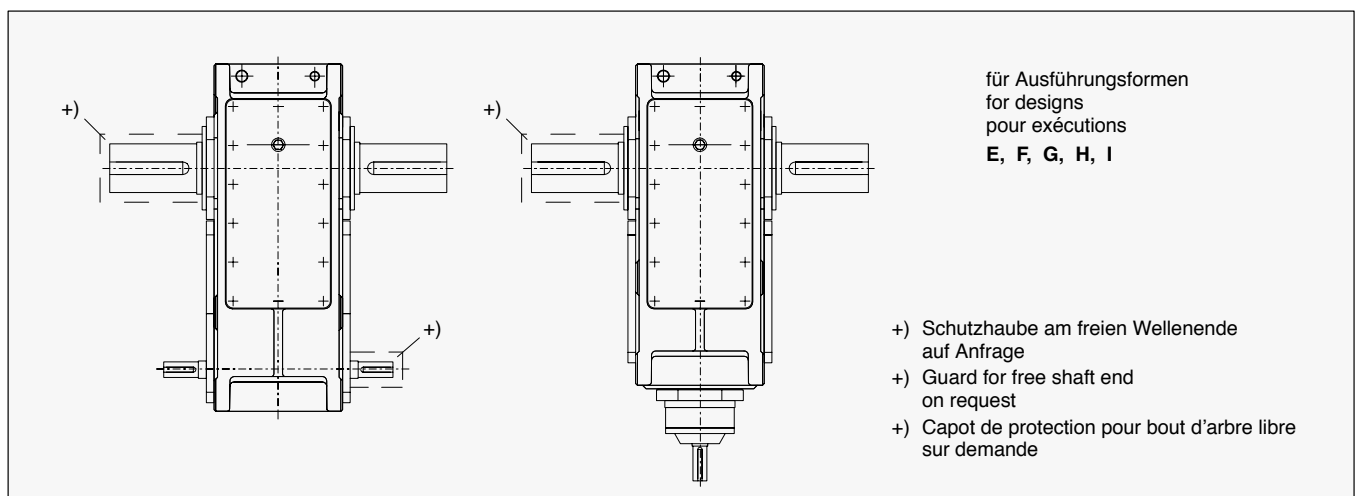

für Ausführungsformen  
für designs  
pour exécutions  
**E, F, G, H, I**

- + ) Schutzhaube am freien Wellenende auf Anfrage
- + ) Guard for free shaft end on request
- + ) Capot de protection pour bout d'arbre libre sur demande

5

Passungsauswahl  
Paßfedern und Nuten

Selection of ISO Fits  
Parallel Keys and Keyways

Choix des tolérances  
Clavettes parallèles et rainures

Passungsauswahl / Selection of ISO fits / Choix des tolérances				
Passungsauswahl Selection of ISO fits Choix des tolérances	Welle / Shaft / Bouts d'arbres d		Wellentoleranz Shaft tolerance Tolérance des bouts d'arbres	Bohrungstoleranz Bore tolerance Tolérance pour les alésages
	über above de mm	bis to jusqu'à mm		
Wellentoleranz nach Flender-Norm Shaft tolerance acc. to Flender standard Tolérance des bouts d'arbres selon standard Flender		25	k6	H7
	25	100	m6	
	100		n6	

Für außergewöhnliche Betriebsverhältnisse, z.B. Reversierbetrieb unter Last, ist ein festerer Sitz und für die Nabennutbreite das ISO-Toleranzfeld P9 vorzusehen.

For heavy-duty operating conditions, e.g. reversing under load, it is recommended that a tighter fit and for the hub keyway width the ISO P9 tolerance is selected.

Pour des conditions de service exceptionnelles, par exemple service à inversion de rotation sous charge, prévoir un serrage plus important et la tolérance ISO P9 pour la largeur b de la rainure dans le moyeu ou un clavetage forcé.

Seitens des Kunden sind hierzu entsprechende Vorgaben notwendig.

In this case, the customer should give the relevant information.

Le client doit préciser dans ce cas les informations relatives nécessaires.

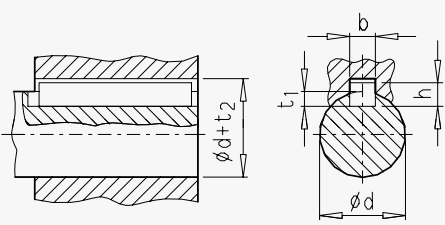
Paßfedern / Parallel keys / Clavettes parallèles							
Mitnehmerverbindung ohne Anzug Drive type fastening without taper action Clavetage libre		Durchmesser Diameter Diamètres d	Breite Width Largeur b	Höhe Height Hauteur h	Wellennuttiefe Depth of keyway in shaft Profondeur de rainure dans l'arbre t <sub>1</sub>	Nabennuttiefe Depth of keyway in hub Profondeur de rainure dans le moyeu d + t <sub>2</sub> DIN 6885/1	
		über above de mm	bis to jusqu'à mm	b <sub>1)</sub> mm	mm	mm	mm
		Paßfeder und Nut nach DIN 6885/1	Parallel key and keyway acc. to DIN 6885/1	Clavette parallèle et rainure selon DIN 6885 feuille 1			
		17	22	6	6	3.5	d + 2.8
		22	30	8	7	4	d + 3.3
		30	38	10	8	5	d + 3.3
		38	44	12	8	5	d + 3.3
		44	50	14	9	5.5	d + 3.8
		50	58	16	10	6	d + 4.3
		58	65	18	11	7	d + 4.4
		65	75	20	12	7.5	d + 4.9
		75	85	22	14	9	d + 5.4
		85	95	25	14	9	d + 5.4
		95	110	28	16	10	d + 6.4
		110	130	32	18	11	d + 7.4
		130	150	36	20	12	d + 8.4
		150	170	40	22	13	d + 9.4
		170	200	45	25	15	d + 10.4
		200	230	50	28	17	d + 11.4
		230	260	56	32	20	d + 12.4
		260	290	63	32	20	d + 12.4
		290	330	70	36	22	d + 14.4
		330	380	80	40	25	d + 15.4
		380	440	90	45	28	d + 17.4

- Das Toleranzfeld der Nabennutbreite b für Paßfedern ist ISO JS9, bzw. ISO P9 bei erschwerten Betriebsbedingungen.
- The tolerance zone for the hub keyway width b for parallel keys is ISO JS9, or ISO P9 for heavy-duty operating conditions.
- La plage de tolérance de la largeur b de la rainure de clavette par rapport à la clavette est ISO JS9, voir ISO P9 en cas de conditions de fonctionnement difficiles.

# Zahnradgetriebe

Hohlwellen für  
Schrumpfscheiben  
Bauarten H2, H3, H4, B3, B4  
Größen 4 - 26

# Gear Units

Hollow Shafts for  
Shrink Disks  
Types H2, H3, H4, B3, B4  
Sizes 4 - 26

# Réducteurs à engrenages

Arbre creux pour frette  
de serrage  
Types H2, H3, H4, B3, B4  
Tailles 4 - 26

X = Platzbedarf für Drehmomentschlüssel berücksichtigen  
X = Space required for torque wrench  
X = Place nécessaire pour la clé dynamométrique

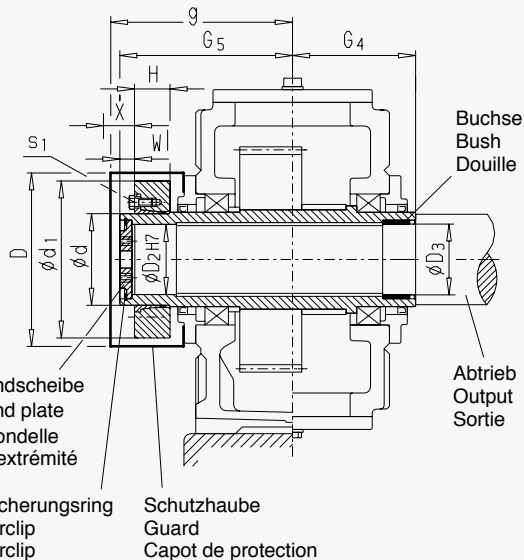

Arbeitsmaschinenwelle für Schrumpfscheibenverbindung, bei Montage nicht gefettet.

Driven machine shaft for shrink disk connection. Driven machine shaft must be free of oil or grease.

Arbre de la machine entraînée pour montage par frette de serrage, dégraissé impérativement lors du montage.

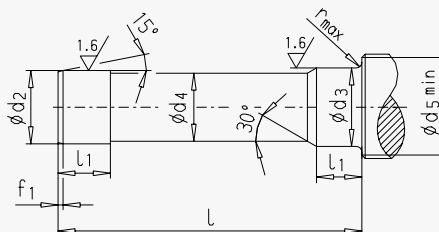

Arbeitsmaschinenwelle mit Zentrierung Form DS (mit Gewinde) nach DIN 332.

Driven machine shaft with centre hole form DS (tapped hole) acc. to DIN 332.

Arbre de la machine entraînée avec centrage forme DS (avec taraudage) selon DIN 332.

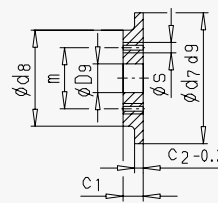

Endscheibe  
End plate  
Rondelle  
d'extrémité

Bauarten / Types H2D., H3D., H4D., B3D., B4D.

Ge- triebe- größe Gear unit size Taille réduc- teur	Arbeitsmaschinenwelle 2) Driven machine shaft Arbre de la machine entraînée											Endscheibe End plate Rondelle d'extrémité					Siche- rungs- ring Circlip Circlip	Hohlwelle Hollow shaft Arbre creux				Schrumpfscheibe Shrink disk Frette de serrage 1)				Schrau- be Screw Vis	Schutz- haube Guard Capot de protection									
	d <sub>2</sub>	d <sub>3</sub>	d <sub>4</sub>	d <sub>5</sub>	f <sub>1</sub>	l	l <sub>1</sub>	r	c <sub>1</sub>	c <sub>2</sub>	d <sub>7</sub>	d <sub>8</sub>	D <sub>9</sub>	m	s	An- zahl Qty. Qté		DIN 472	D <sub>2</sub>	D <sub>3</sub>	G <sub>4</sub>	G <sub>5</sub>	Bauart Type HSD	d	d <sub>1</sub>		H	W	D	g						
	mm																	mm																		
4	85 g6	85 h6	84.5	95	4	326	48	2	17	7	90	70	22	50	M 8	2	90 x 3	85	85	140	205	110-32	110	185	51	20	M 12	235	225							
5	100 g6	100 h6	99.5	114	5	383	53	2	20	8	105	80	26	55	M 10	2	105 x 4	100	100	165	240	125-32	125	215	55	20	M 12	275	260							
6	110 g6	110 h6	109.5	124	5	383	58	3	20	8	115	85	26	60	M 10	2	115 x 4	110	110	165	240	140-32	140	230	61	20	M 14	285	255							
7	120 g6	120 h6	119.5	134	5	453	68	3	20	8	125	90	26	65	M 12	2	125 x 4	120	120	195	280	155-32	155	263	64	23	M 14	330	305							
8	130 g6	130 h6	129.5	145	6	458	73	3	20	8	135	100	26	70	M 12	2	135 x 4	130	130	195	285	165-32	165	290	70	23	M 16	340	305							
9	140 g6	145 m6	139.5	160	6	539	82	4	23	10	150	110	33	80	M 12	2	150 x 4	140	145	235	330	175-32	175	300	71	28	M 16	360	355							
10	150 g6	155 m6	149.5	170	6	559	92	4	23	10	160	120	33	90	M 12	2	160 x 4	150	155	235	350	200-32	200	340	87	28	M 16	395	365							
11	165 f6	170 m6	164.5	185	7	644	112	4	23	10	175	130	33	90	M 12	2	175 x 4	165	170	270	400	220-32	220	370	103	30	M 20	435	420							
12	180 f6	185 m6	179.5	200	7	649	122	4	23	10	190	140	33	100	M 16	2	190 x 4	180	185	270	405	240-32	240	405	107	30	M 20	450	420							
13	190 f6	195 m6	189.5	213	7	789	137	5	23	10	200	150	33	110	M 16	2	200 x 4	190	195	335	480	260-32	260	430	119	30	M 20	500	505							
14	210 f6	215 m6	209.5	233	8	784	147	5	28	14	220	170	33	130	M 16	2	220 x 5	210	215	335	480	280-32	280	460	132	30	M 20	525	505							
15	230 f6	235 m6	229.5	253	8	899	157	5	28	14	240	180	39	140	M 16	2	240 x 5	230	235	380	550	300-32	300	485	140	35	M 24	575	575							
16	240 f6	245 m6	239.5	263	8	899	157	5	28	14	250	190	39	150	M 20	2	250 x 5	240	245	380	550	320-32	320	520	140	35	M 24	595	575							
17	250 f6	260 m6	249.5	278	8	982	177	5	30	14	265	200	39	150	M 20	2	265 x 5	250	260	415	600	340-32	340	570	155	35	M 24	615	630							
18	280 f6	285 m6	279.5	306	9	982	177	5	30	14	290	210	39	160	M 20	2	290 x 5	280	285	415	600	360-32	360	590	162	35	M 24	635	625							
19	285 f6	295 m6	284.5	316	9	1100	187	5	32	15	300	220	39	170	M 24	2	300 x 5	285	295	465	670	380-32	380	640	166	40	M 27	-	-							
20	310 f6	315 m6	309.5	336	9	1100	187	5	32	15	320	230	39	180	M 24	2	320 x 6	310	315	465	670	390-32	390	650	166	40	M 27	-	-							
21	330 f6	335 m6	329	358	9	1160	205	5	40	20	340	250	45	190	M 24	2	340 x 6	330	335	490	715	420-32	420	670	186	45	M 27	-	-							
22	340 f6	345 m6	339	368	9	1170	215	5	40	20	350	260	45	200	M 24	2	350 x 6	340	345	490	725	440-32	440	720	194	45	M 27	-	-							
23 - 26	Auf Anfrage / On request / Sur demande																																			

1) Schrumpfscheibe gehört nicht zum Liefer-  
umfang. Bei Bedarf gesondert bestellen.  
Schrumpfscheibe wird bei Bestellung lose  
mitgeliefert.

1) Shrink disk does not belong to our scope of  
supply. Please order separately, if required.  
In case of order, shrink disk will be supplied  
as loose item.

1) La frette de serrage ne fait pas partie de la  
livraison. La commander spécialement.  
En cas de commande la frette de serrage  
sera livrée séparément.

2) Werkstoff Arbeitsmaschinenwelle C60N oder  
höhere Festigkeit.

2) Material of driven machine shaft: C60N or  
higher strength.

2) Matière de l'arbre machine entraînée: C60N  
ou qualité supérieure.

Schrumpfscheibe an Maschinenseite auf An-  
frage.

Shrink disk on machine side on request.

Frette de serrage côté machine sur demande.

# Zahnradgetriebe

Hohlwellen für  
Schrumpfscheiben  
Bauart B2  
Größen 4 - 18

# Gear Units

Hollow Shafts for  
Shrink Disks  
Type B2  
Sizes 4 - 18

# Réducteurs à engrenages

Arbre creux pour frette  
de serrage  
Type B2  
Tailles 4 - 18

X = Platzbedarf für Drehmomentschlüssel berücksichtigen  
X = Space required for torque wrench  
X = Place nécessaire pour la clé dynamométrique

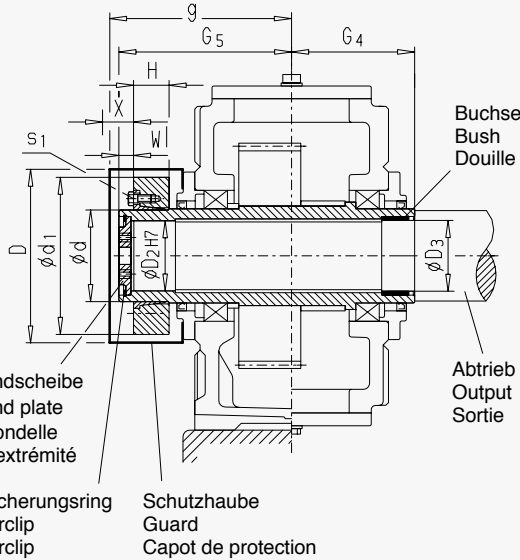

Arbeitsmaschinenwelle für Schrumpfscheibenverbindung, bei Montage nicht gefettet.

Driven machine shaft for shrink disk connection. Driven machine shaft must be free of oil or grease.

Arbre de la machine entraînée pour montage par frette de serrage, dégraissé impérativement lors du montage.

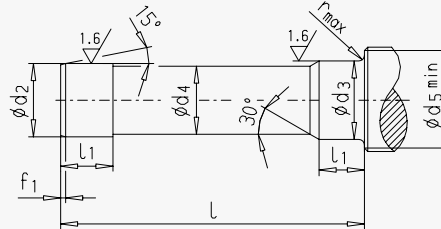

Arbeitsmaschinenwelle mit Zentrierung Form DS (mit Gewinde) nach DIN 332.

Driven machine shaft with centre hole form DS (tapped hole) acc. to DIN 332.

Arbre de la machine entraînée avec centrage forme DS (avec taraudage) selon DIN 332.

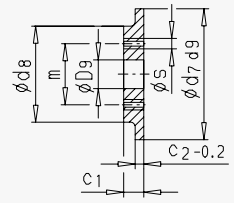

Endscheibe  
End plate  
Rondelle  
d'extrémité

## Bauart / Type B2D.

Ge- triebe- größe Gear unit size Taille réduc- teur	Arbeitsmaschinenwelle <sup>2)</sup> Driven machine shaft Arbre de la machine entraînée														Endscheibe End plate Rondelle d'extrémité		Siche- rungs- ring Circlip Circlip	Hohlwelle Hollow shaft Arbre creux				Schrumpfscheibe Shrink disk Frette de serrage <sup>1)</sup>				Schrau- be Screw Vis	Schutz- haube Guard Capot de protection						
	d <sub>2</sub>	d <sub>3</sub>	d <sub>4</sub>	d <sub>5</sub>	f <sub>1</sub>	l	l <sub>1</sub>	r	c <sub>1</sub>	c <sub>2</sub>	d <sub>7</sub>	d <sub>8</sub>	D <sub>9</sub>	m	s	An- zahl Qty. Qté		DIN 472	D <sub>2</sub>	D <sub>3</sub>	G <sub>4</sub>	G <sub>5</sub>	Bauart Type HSD	d	d <sub>1</sub>		H	W	s <sub>1</sub>	D	g		
	mm																	mm															
4	85 g6	85 h6	84.5	95	4	386	48	2	17	7	90	70	22	50	M 8	2	90 x 3	85	85	170	235	110-32	110	185	51	20	M 12	235	255				
5	100 g6	100 h6	99.5	114	5	453	53	2	20	8	105	80	26	55	M 10	2	105 x 4	100	100	200	275	125-32	125	215	55	20	M 12	275	290				
6	110 g6	110 h6	109.5	124	5	453	58	3	20	8	115	85	26	60	M 10	2	115 x 4	110	110	200	275	140-32	140	230	61	20	M 14	285	285				
7	120 g6	120 h6	119.5	134	5	533	68	3	20	8	125	90	26	65	M 12	2	125 x 4	120	120	235	320	155-32	155	263	64	23	M 14	330	345				
8	130 g6	130 h6	129.5	145	6	538	73	3	20	8	135	100	26	70	M 12	2	135 x 4	130	130	235	325	165-32	165	290	70	23	M 16	340	345				
9	140 g6	145 m6	139.5	160	6	609	82	4	23	10	150	110	33	80	M 12	2	150 x 4	140	145	270	365	175-32	175	300	71	28	M 16	360	390				
10	150 g6	155 m6	149.5	170	6	629	92	4	23	10	160	120	33	90	M 12	2	160 x 4	150	155	270	385	200-32	200	340	87	28	M 16	395	400				
11	165 f6	170 m6	164.5	185	7	744	112	4	23	10	175	130	33	90	M 12	2	175 x 4	165	170	320	450	220-32	220	370	103	30	M 20	435	470				
12	180 f6	185 m6	179.5	200	7	749	122	4	23	10	190	140	33	100	M 16	2	190 x 4	180	185	320	455	240-32	240	405	107	30	M 20	450	470				
14	210 f6	215 m6	209.5	233	8	894	147	5	28	14	220	170	33	130	M 16	2	220 x 5	210	215	390	535	280-32	280	460	132	30	M 20	525	555				
16	240 f6	245 m6	239.5	263	8	1039	157	5	28	14	250	190	39	150	M 20	2	250 x 5	240	245	450	620	320-32	320	520	140	35	M 24	595	645				
18	280 f6	285 m6	279.5	306	9	1177	177	5	30	14	290	210	39	160	M 20	2	290 x 5	280	285	510	700	360-32	360	590	162	35	M 24	635	725				

1) Schrumpfscheibe gehört nicht zum Liefer-  
umfang. Bei Bedarf gesondert bestellen.  
Schrumpfscheibe wird bei Bestellung lose  
mitgeliefert.

2) Werkstoff Arbeitsmaschinenwelle C60N oder  
höhere Festigkeit.

Schrumpfscheibe an Maschinenseite auf An-  
frage.

1) Shrink disk does not belong to our scope of  
supply. Please order separately, if required.  
In case of order, shrink disk will be supplied  
as loose item.

2) Material of driven machine shaft: C60N or  
higher strength.

Shrink disk on machine side on request.

1) La frette de serrage ne fait pas partie de la  
livraison. La commander spécialement.  
En cas de commande la frette de serrage  
sera livrée séparément.

2) Matière de l'arbre machine entraînée: C60N  
ou qualité supérieure.

Frette de serrage côté machine sur demande.

## Zahnradgetriebe

Hohlwellen für  
Paßfederverbindungen  
Bauarten H2, H3, H4, B3, B4  
Größen 4 - 18

## Gear Units

Hollow Shafts for Parallel  
Key Connections  
Types H2, H3, H4, B3, B4  
Sizes 4 - 18

## Réducteurs à engrenages

Arbre creux pour  
raccord de clavette  
Types H2, H3, H4, B3, B4  
Tailles 4 - 18

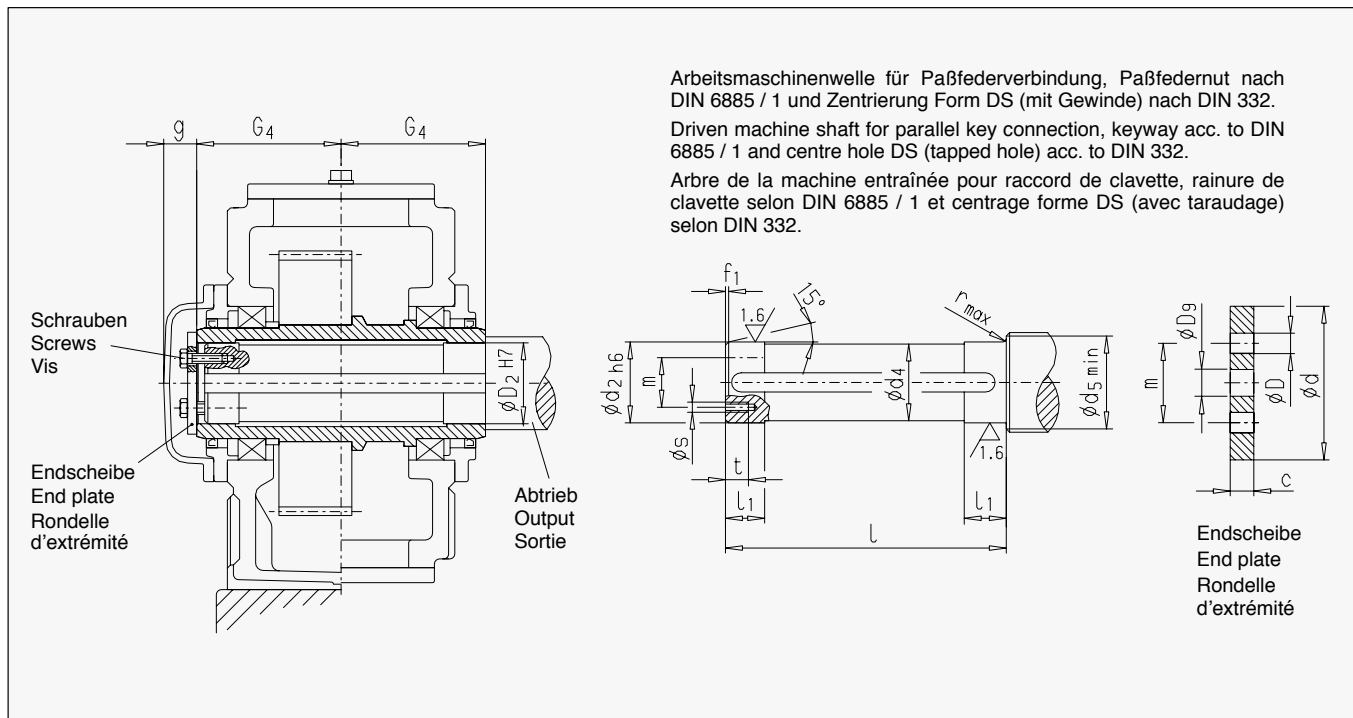

Bauarten / Types **H2H., H3H., H4H., B3H., B4H.**

Ge- triebe größe Gear unit size Taille réduc- teur	Arbeitsmaschinenwelle <sup>1)</sup> Driven machine shaft Arbre de la machine entraînée										Endscheibe End plate Rondelle d'extrémité					Schraube Screw Vis		Hohlwelle Hollow shaft Arbre creux		
	d <sub>2</sub>	d <sub>4</sub>	d <sub>5</sub>	f <sub>1</sub>	l	l <sub>1</sub>	r	s	t	c	D	D <sub>9</sub>	d	m	Größe Size Taille	An- zahl Qty. Qté	D <sub>2</sub>	G <sub>4</sub>	g	
	mm																	mm		
<b>4</b>	80	79.5	88	4	278	35	1.2	M 10	18	10	11	22	100	60	M 10 x 25	2	80	140	35	
<b>5</b>	95	94.5	105	5	328	40	1.6	M 10	18	10	11	26	120	70	M 10 x 25	2	95	165	40	
<b>6</b>	105	104.5	116	5	328	45	1.6	M 10	18	10	11	26	120	70	M 10 x 25	2	105	165	40	
<b>7</b>	115	114.5	126	5	388	50	1.6	M 12	20	12	13.5	26	140	80	M 12 x 30	2	115	195	40	
<b>8</b>	125	124.5	136	6	388	55	2.5	M 12	20	12	13.5	26	150	85	M 12 x 30	2	125	195	40	
<b>9</b>	135	134.5	147	6	467	60	2.5	M 12	20	12	13.5	33	160	90	M 12 x 30	2	135	235	45	
<b>10</b>	150	149.5	162	6	467	65	2.5	M 12	20	12	13.5	33	185	110	M 12 x 30	2	150	235	45	
<b>11</b>	165	164.5	177	7	537	70	2.5	M 16	28	15	17.5	33	195	120	M 16 x 40	2	165	270	45	
<b>12</b>	180	179.5	192	7	537	75	2.5	M 16	28	15	17.5	33	220	130	M 16 x 40	2	180	270	45	
<b>13</b>	190	189.5	206	7	667	80	3	M 16	28	18	17.5	33	230	140	M 16 x 40	2	190	335	45	
<b>14</b>	210	209.5	226	8	667	85	3	M 16	28	18	17.5	33	250	160	M 16 x 40	2	210	335	45	
<b>15</b>	230	229.5	248	8	756	100	3	M 20	38	25	22	39	270	180	M 20 x 55	4	230	380	60	
<b>16</b>	240	239.5	258	8	756	100	3	M 20	38	25	22	39	280	180	M 20 x 55	4	240	380	60	
<b>17</b>	250	249.5	270	8	826	110	4	M 20	38	25	22	39	300	190	M 20 x 55	4	250	415	60	
<b>18</b>	275	274.5	295	9	826	120	4	M 20	38	25	22	39	330	210	M 20 x 55	4	275	415	60	

1) Werkstoff Arbeitsmaschinenwelle C60N oder höhere Festigkeit.

Paßfeder gehört nicht zum Lieferumfang. Bei Bedarf gesondert bestellen.

1) Material of driven machine shaft: C60N or higher strength.

Parallel key does not belong to our scope of supply. Please order separately, if required.

1) Matière de l'arbre machine entraînée: C60N ou qualité supérieure.

La clavette ne fait pas partie de la livraison. La commander spécialement.

## Zahnradgetriebe

Hohlwellen für  
Paßfederverbindungen  
Bauart B2  
Größen 4 - 18

## Gear Units

Hollow Shafts for Parallel  
Key Connections  
Type B2  
Sizes 4 - 18

## Réducteurs à engrenages

Arbre creux pour  
raccord de clavette  
Type B2  
Tailles 4 - 18

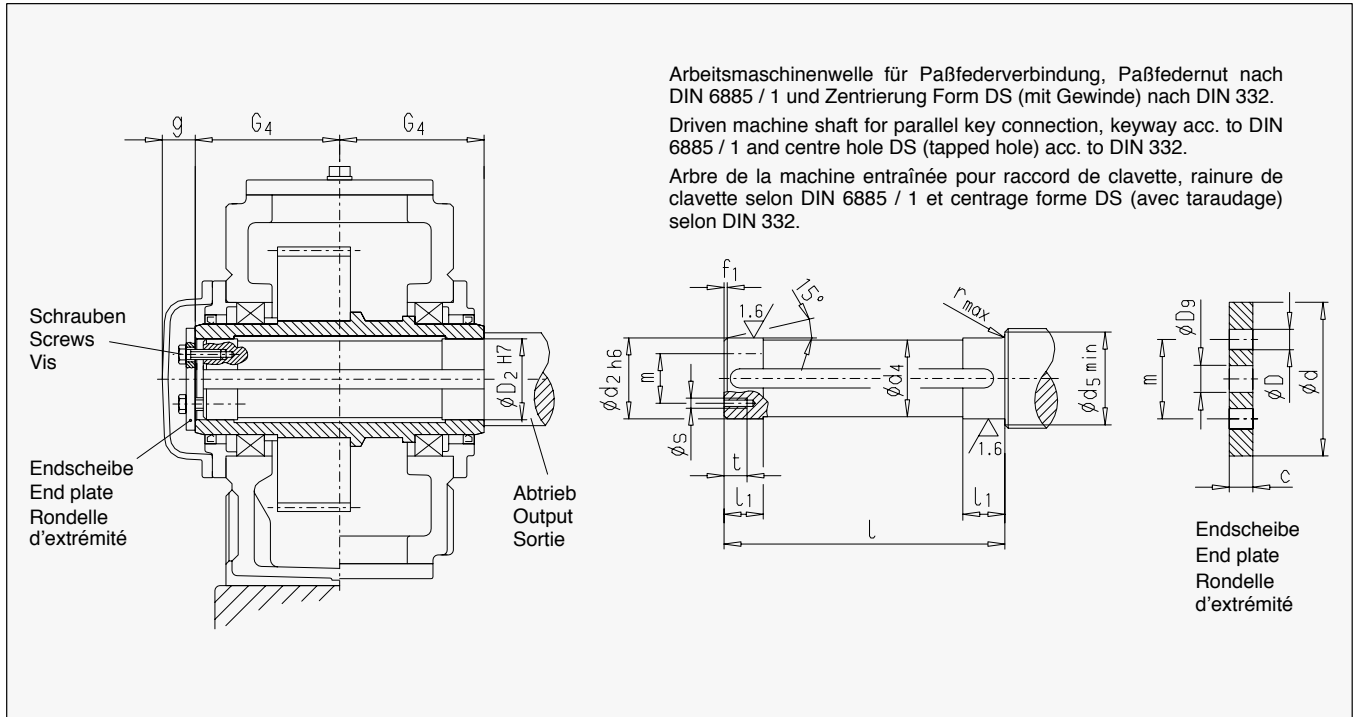

Bauart / Type B2H.

Ge- triebe- größe Gear unit size Taille réduc- teur	Arbeitsmaschinenwelle <sup>1)</sup> Driven machine shaft Arbre de la machine entraînée																		Schraube Screw Vis		Hohlwelle Hollow shaft Arbre creux		
	d <sub>2</sub>	d <sub>4</sub>	d <sub>5</sub>	f <sub>1</sub>	l	l <sub>1</sub>	r	s	t	c	D	D <sub>9</sub>	d	m	Größe Size Taille	An- zahl Qty. Qté	D <sub>2</sub>	G <sub>4</sub>	g				
	mm																				mm		
4	80	79.5	88	4	338	35	1.2	M 10	18	10	11	22	100	60	M 10 x 25	2	80	170	35				
5	95	94.5	105	5	398	40	1.6	M 10	18	10	11	26	120	70	M 10 x 25	2	95	200	40				
6	105	104.5	116	5	398	45	1.6	M 10	18	10	11	26	120	70	M 10 x 25	2	105	200	40				
7	115	114.5	126	5	468	50	1.6	M 12	20	12	13.5	26	140	80	M 12 x 30	2	115	235	40				
8	125	124.5	136	6	468	55	2.5	M 12	20	12	13.5	26	150	85	M 12 x 30	2	125	235	40				
9	135	134.5	147	6	537	60	2.5	M 12	20	12	13.5	33	160	90	M 12 x 30	2	135	270	45				
10	150	149.5	162	6	537	65	2.5	M 12	20	12	13.5	33	185	110	M 12 x 30	2	150	270	45				
11	165	164.5	177	7	637	70	2.5	M 16	28	15	17.5	33	195	120	M 16 x 40	2	165	320	45				
12	180	179.5	192	7	637	75	2.5	M 16	28	15	17.5	33	220	130	M 16 x 40	2	180	320	45				
14	210	209.5	226	8	777	85	3	M 16	28	18	17.5	33	250	160	M 16 x 40	2	210	390	45				
16	240	239.5	258	8	896	100	3	M 20	38	25	22	39	280	180	M 20 x 55	4	240	450	60				
18	275	274.5	295	9	1016	120	4	M 20	38	25	22	39	330	210	M 20 x 55	4	275	510	60				

1) Werkstoff Arbeitsmaschinenwelle C60N oder höhere Festigkeit.

Paßfeder gehört nicht zum Lieferumfang. Bei Bedarf gesondert bestellen.

1) Material of driven machine shaft: C60N or higher strength.

Parallel key does not belong to our scope of supply. Please order separately, if required.

1) Matière de l'arbre machine entraînée: C60N ou qualité supérieure.

La clavette ne fait pas partie de la livraison. La commander spécialement.

## Zahnradgetriebe

Hohlwelle mit Zahnradprofil  
nach DIN 5480  
Bauarten H2, H3, H4, B3, B4  
Größen 5 - 26

## Gear Units

Hollow Shaft With Involute  
Splines acc. to DIN 5480  
Types H2, H3, H4, B3, B4  
Sizes 5 - 26

## Réducteurs à engrenages

Arbre creux cannelé  
selon DIN 5480  
Types H2, H3, H4, B3, B4  
Tailles 5 - 26

K20/004

Arbeitsmaschinenwelle für Zahnprofilverbindung, bei Montage gefettet  
Driven machine shaft for connection via involute splines, to be greased on assembly  
Arbre machine pour liaison cannelée, à graisser impérativement au montage

Buchse  
Bush  
Douille

Sicherungsring  
Circlip  
Circlip

Endscheibe  
End plate  
Rondelle d'extrémité

Abtrieb  
Output  
Sortie

Endscheibe  
End plate  
Rondelle d'extrémité

Arbeitsmaschinenwelle mit Zentrierung Form DS (mit Gewinde) nach DIN 332  
Driven machine shaft with centre hole form DS (tapped hole) acc. to DIN 332  
Arbre de la machine de travail avec centrage forme DS (avec taraudage) selon DIN 332

Endscheibe und Sicherungsring gehören zu unserer Lieferung  
End plate and circlip are supplied by us  
Rondelle d'extrémité et circlip font partie de notre fourniture

Bauarten / Types **H2K., H3K., H4K., B3K., B4K.**

Ge- triebe- größe Gear unit size Taille réduc- teur	Zahnwellenprofil Involute splines Cannelures DIN 5480	Arbeitsmaschinenwelle <sup>1)</sup> Driven machine shaft Arbre de la machine entraînée										Endscheibe End plate Rondelle d'extrémité						Sicherungs- ring Circlip DIN 472	Hohlwelle Hollow shaft Arbre creux				Schrau- be Screw Vis	
		d <sub>2</sub>	d <sub>3</sub>	d <sub>4</sub>	d <sub>5</sub>	f <sub>1</sub>	l	l <sub>1</sub>	l <sub>2</sub>	r	c <sub>1</sub>	c <sub>2</sub>	d <sub>7</sub>	d <sub>8</sub>	D <sub>9</sub>	m	s		An- zahl Qty. Qté	D <sub>2</sub>	D <sub>3</sub>	G <sub>4</sub>		g
		mm										mm												
5	W 95x3x30x30x8f	94.4	100 h6	93	114	3	308	53	90	2	20	8	105	80	26	55	M 10	2	105x4	89	100	165	40	M 24
6	W 95x3x30x30x8f	94.4	110 h6	93	124	3	308	58	90	3	20	8	105	80	26	55	M 10	2	105x4	89	110	165	40	M 24
7	W120x3x30x38x8f	119.4	120 h6	118	134	3	368	68	105	3	20	8	125	90	26	65	M 12	2	125x4	114	120	195	40	M 24
8	W120x3x30x38x8f	119.4	130 h6	118	145	3	368	73	105	3	20	8	125	90	26	65	M 12	2	125x4	114	130	195	40	M 24
9	W140x3x30x45x8f	139.4	145 m6	138	160	3	444	82	125	4	23	10	150	110	33	80	M 12	2	150x4	134	145	235	45	M 30
10	W140x3x30x45x8f	139.4	155 m6	138	170	3	444	92	125	4	23	10	150	110	33	80	M 12	2	150x4	134	155	235	45	M 30
11	W170x5x30x32x8f	169	170 m6	168	185	5	514	112	150	4	23	10	175	130	33	90	M 12	2	175x4	160	170	270	45	M 30
12	W170x5x30x32x8f	169	185 m6	168	200	5	514	122	150	4	23	10	175	130	33	90	M 12	2	175x4	160	185	270	45	M 30
13	W190x5x30x36x8f	189	195 m6	188	213	5	644	137	180	5	23	10	200	150	33	110	M 16	2	200x4	180	195	335	45	M 30
14	W190x5x30x36x8f	189	215 m6	188	233	5	644	147	180	5	23	10	200	150	33	110	M 16	2	200x4	180	215	335	45	M 30
15	W220x5x30x42x8f	219	235 m6	218	253	5	728	157	200	5	28	14	240	180	39	140	M 16	2	240x5	210	235	380	60	M 36
16	W220x5x30x42x8f	219	245 m6	218	263	5	728	157	200	5	28	14	240	180	39	140	M 16	2	240x5	210	245	380	60	M 36
17	W250x5x30x48x8f	249	260 m6	248	278	5	796	177	215	5	30	14	265	200	39	150	M 20	2	265x5	240	260	415	60	M 36
18	W250x5x30x48x8f	249	285 m6	248	306	5	796	177	215	5	30	14	265	200	39	150	M 20	2	265x5	240	285	415	60	M 36
19-26	Auf Anfrage / On request / Sur demande																							

1) Werkstoff Arbeitsmaschinenwelle C60N oder höhere Festigkeit.

1) Material of driven machine shaft: C60N or higher strength.

1) Matière de l'arbre machine: C60N ou qualité supérieure.



# Zahnradgetriebe

Hohlwelle mit Zahnradprofil nach DIN 5480  
 Bauart B2  
 Größen 5 - 18

# Gear Units

Hollow Shaft With Involute Splines acc. to DIN 5480  
 Type B2  
 Sizes 5 - 18

# Réducteurs à engrenages

Arbre creux cannelé selon DIN 5480  
 Type B2  
 Tailles 5 - 18

K20/004

**Arbeitsmaschinenwelle für Zahnprofilverbindung, bei Montage gefettet**  
 Driven machine shaft for connection via involute splines, to be greased on assembly  
 Arbre machine pour liaison cannelée, à graisser impérativement au montage

**Endscheibe**  
 End plate  
 Rondelle d'extrémité

**Arbeitsmaschinenwelle mit Zentrierung Form DS (mit Gewinde) nach DIN 332**  
 Driven machine shaft with centre hole form DS (tapped hole) acc. to DIN 332  
 Arbre de la machine de travail avec centrage forme DS (avec taraudage) selon DIN 332

Endscheibe und Sicherungsring gehören zu unserer Lieferung  
 End plate and circlip are supplied by us  
 Rondelle d'extrémité et circlip font partie de notre fourniture

Bauart / Type <b>B2K.</b>																								
Ge- triebe- größe Gear unit size Taille réduc- teur	Arbeitsmaschinenwelle <sup>1)</sup> Driven machine shaft Arbre de la machine entraînée											Endscheibe End plate Rondelle d'extrémité						Sicher- ungs- ring Circlip DIN 472	Hohlwelle Hollow shaft Arbre creux				Schrau- be Screw Vis	
	Zahnwellenprofil Involute splines Cannelures DIN 5480	d <sub>2</sub>	d <sub>3</sub>	d <sub>4</sub>	d <sub>5</sub>	f <sub>1</sub>	l	l <sub>1</sub>	l <sub>2</sub>	r	c <sub>1</sub>	c <sub>2</sub>	d <sub>7</sub>	d <sub>8</sub>	D <sub>9</sub>	m	s		An- zahl Qty. Qté	D <sub>2</sub>	D <sub>3</sub>	G <sub>4</sub>		g
		mm										mm												
<b>5</b>	W 95x3x30x30x8f	94.4	100 h6	93	114	3	378	53	90	2	20	8	105	80	26	55	M 10	2	105x4	89	100	200	40	M 24
<b>6</b>	W 95x3x30x30x8f	94.4	110 h6	93	124	3	378	58	90	3	20	8	105	80	26	55	M 10	2	105x4	89	110	200	40	M 24
<b>7</b>	W120x3x30x38x8f	119.4	120 h6	118	134	3	448	68	105	3	20	8	125	90	26	65	M 12	2	125x4	114	120	235	40	M 24
<b>8</b>	W120x3x30x38x8f	119.4	130 h6	118	145	3	448	73	105	3	20	8	125	90	26	65	M 12	2	125x4	114	130	235	40	M 24
<b>9</b>	W140x3x30x45x8f	139.4	145 m6	138	160	3	514	82	125	4	23	10	150	110	33	80	M 12	2	150x4	134	145	270	45	M 30
<b>10</b>	W140x3x30x45x8f	139.4	155 m6	138	170	3	514	92	125	4	23	10	150	110	33	80	M 12	2	150x4	134	155	270	45	M 30
<b>11</b>	W170x5x30x32x8f	169	170 m6	168	185	5	614	112	150	4	23	10	175	130	33	90	M 12	2	175x4	160	170	320	45	M 30
<b>12</b>	W170x5x30x32x8f	169	185 m6	168	200	5	614	122	150	4	23	10	175	130	33	90	M 12	2	175x4	160	185	320	45	M 30
<b>14</b>	W190x5x30x36x8f	189	215 m6	188	233	5	754	147	180	5	23	10	200	150	33	110	M 16	2	200x4	180	215	390	45	M 30
<b>16</b>	W220x5x30x42x8f	219	245 m6	218	263	5	868	157	200	5	28	14	240	180	39	140	M 16	2	240x5	210	245	450	60	M 36
<b>18</b>	W250x5x30x48x8f	249	285 m6	248	306	5	986	177	215	5	30	14	265	200	39	150	M 20	2	265x5	240	285	510	60	M 36

1) Werkstoff Arbeitsmaschinenwelle C60N oder höhere Festigkeit.

1) Material of driven machine shaft: C60N or higher strength.

1) Matière de l'arbre machine: C60N ou qualité supérieure.

# Zahnradgetriebe

Gegenflansche für  
Flanschwellen  
Bauarten H2, H3, H4, B2, B3, B4  
Größen 5 - 12

# Gear Units

Counterflanges for  
Flanged Shafts  
Types H2, H3, H4, B2, B3, B4  
Sizes 5 - 12

# Réducteurs à engrenages

Contre-bride  
pour arbre à bride  
Types H2, H3, H4, B2, B3, B4  
Tailles 5 - 12

K20/028

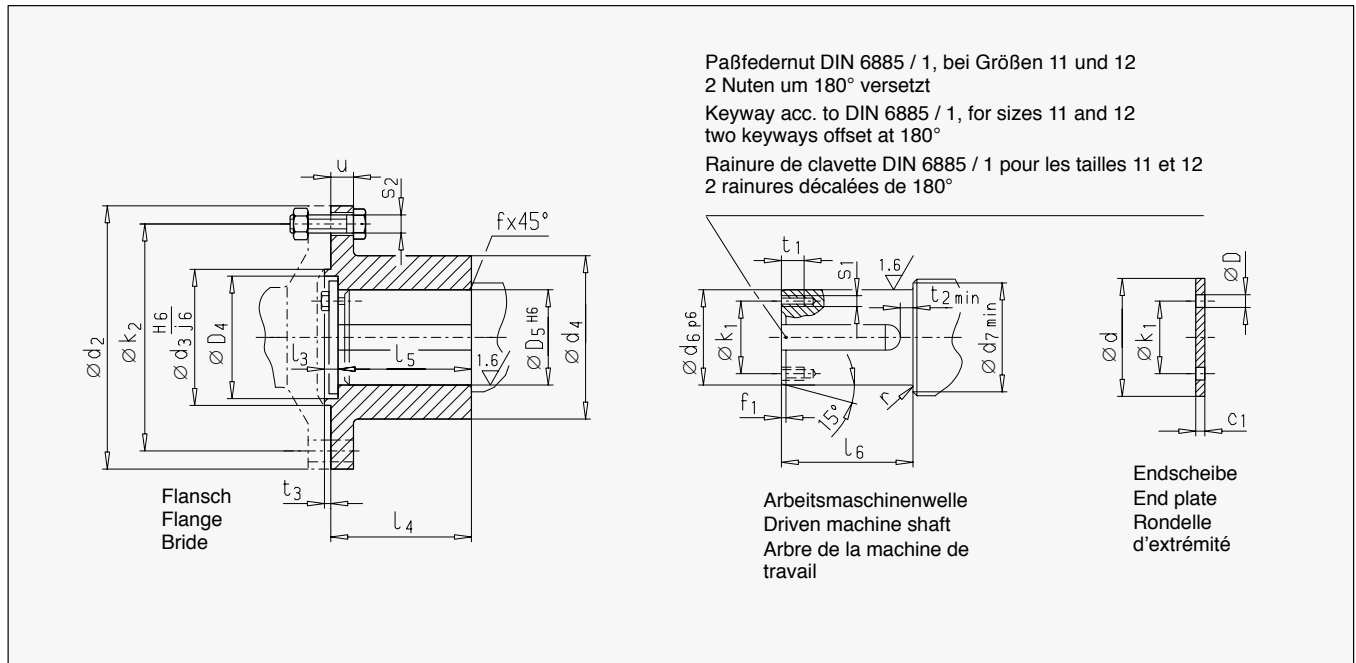

Paßfedernut DIN 6885 / 1, bei Größen 11 und 12  
2 Nuten um 180° versetzt  
Keyway acc. to DIN 6885 / 1, for sizes 11 and 12  
two keyways offset at 180°  
Rainure de clavette DIN 6885 / 1 pour les tailles 11 et 12  
2 rainures décalées de 180°

Bauarten / Types H2F, H3F., H4F, B2F., B3F, B4F.																
Getriebe- größe Gear unit size Taille réducteur	Flansch / Flange / Bride													Schraube <sup>1)</sup> Bolt / Vis		
	d <sub>2</sub>	d <sub>3</sub>	d <sub>4</sub>	D <sub>4</sub>	D <sub>5</sub>	f	k <sub>2</sub>	l <sub>3</sub>	l <sub>4</sub>	l <sub>5</sub>	s <sub>2</sub>	t <sub>3</sub>	u	Größe Size Taille	Anzahl Qty. Qté	T <sub>A</sub> <sup>2)</sup> Nm
	mm															
5	300	150	190	135	110	2.5	260	16	175	167	M 20	8	25	M 20 x 70	16	610
6	320	160	210	145	120	2.5	280	22	185	171	M 20	8	25	M 20 x 70	18	610
7	370	180	230	160	135	2.5	320	21	220	207	M 24	8	30	M 24 x 90	16	1050
8	390	190	270	175	150	2.5	340	22	220	206	M 24	8	30	M 24 x 90	18	1050
9	430	220	290	195	160	4.0	380	22	250	238	M 24	10	38	M 24 x 100	20	1050
10	470	240	310	220	180	4.0	420	22	250	238	M 24	10	38	M 24 x 100	22	1050
11	510	260	340	235	200	4.0	450	22	290	278	M 30	10	42	M 30 x 120	18	2100
12	540	280	360	255	210	4.0	480	22	290	278	M 30	10	42	M 30 x 120	22	2100

Getriebe- größe Gear unit size Taille réduc- teur	Arbeitsmaschinenwelle Driven machine shaft Arbre de la machine de travail										Endscheibe End plate Rondelle d'extrémité				Schraube Bolt / Vis		Gewicht Weight Poids kg
	d <sub>6</sub>	d <sub>7</sub>	f <sub>1</sub>	k <sub>1</sub>	l <sub>6</sub>	r	s <sub>1</sub>	t <sub>1</sub>	t <sub>2</sub>	c <sub>1</sub>	d	D	k <sub>1</sub>	Größe Size Taille	Anzahl Qty. Qté		
	mm										mm						
5	110	122	2.5	80	165	2	M 12	28	7.5	10	130	13.5	80	M 12 x 35	4	35	
6	120	132	2.5	95	169	2	M 16	32	7.5	14	140	17.5	95	M 16 x 45	4	45	
7	135	147	2.5	95	205	2	M 16	32	16	14	155	17.5	95	M 16 x 45	4	65	
8	150	162	2.5	110	204	2	M 16	32	16	16	170	17.5	110	M 16 x 45	4	85	
9	160	176	4.0	110	235	3	M 16	32	16	16	190	17.5	110	M 16 x 45	4	115	
10	180	196	4.0	145	235	3	M 20	38	16	18	215	22	145	M 20 x 55	4	130	
11	200	216	4.0	145	275	3	M 20	38	16	18	230	22	145	M 20 x 55	4	175	
12	210	230	4.0	160	275	3	M 20	38	16	18	250	22	160	M 20 x 55	4	200	

Paßfeder gehört nicht zum Lieferumfang.  
Bei Bedarf gesondert bestellen.

- Schrauben nach DIN 931, Werkstoff 10.9;  
Mutter nach DIN 934, Werkstoff 10
- Anzugsmoment der Flanschverbindungs-  
schraube

Werkstoffe der Flansche und Arbeitsmaschinen-  
wellen C60N oder höhere Festigkeit.

Parallel key does not belong to our scope of  
supply. Please order separately, if required.

- Bolts acc. to DIN 931, material 10.9;  
Nuts acc. to DIN 934, material 10
- Tightening torque of flange connection bolts

Material of flanges and driven machine shafts:  
C60N or higher strength.

La clavette ne fait pas partie de la livraison.  
La commander spécialement.

- Vis selon DIN 931, matière 10.9;  
Écrous selon DIN 934, matière 10
- Couple de serrage des vis de raccord de bride

Matières des brides et arbres de la machine de  
travail C60N ou meilleure résistance.

## Zahnradgetriebe

Gegenflansche für  
Flanschwellen  
Bauarten H2, H3, H4, B2, B3, B4  
Größen 13 - 26

## Gear Units

Counterflanges for  
Flanged Shafts  
Types H2, H3, H4, B2, B3, B4  
Sizes 13 - 26

## Réducteurs à engrenages

Contre-bride  
pour arbre à bride  
Types H2, H3, H4, B2, B3, B4  
Tailles 13 - 26

K20/028

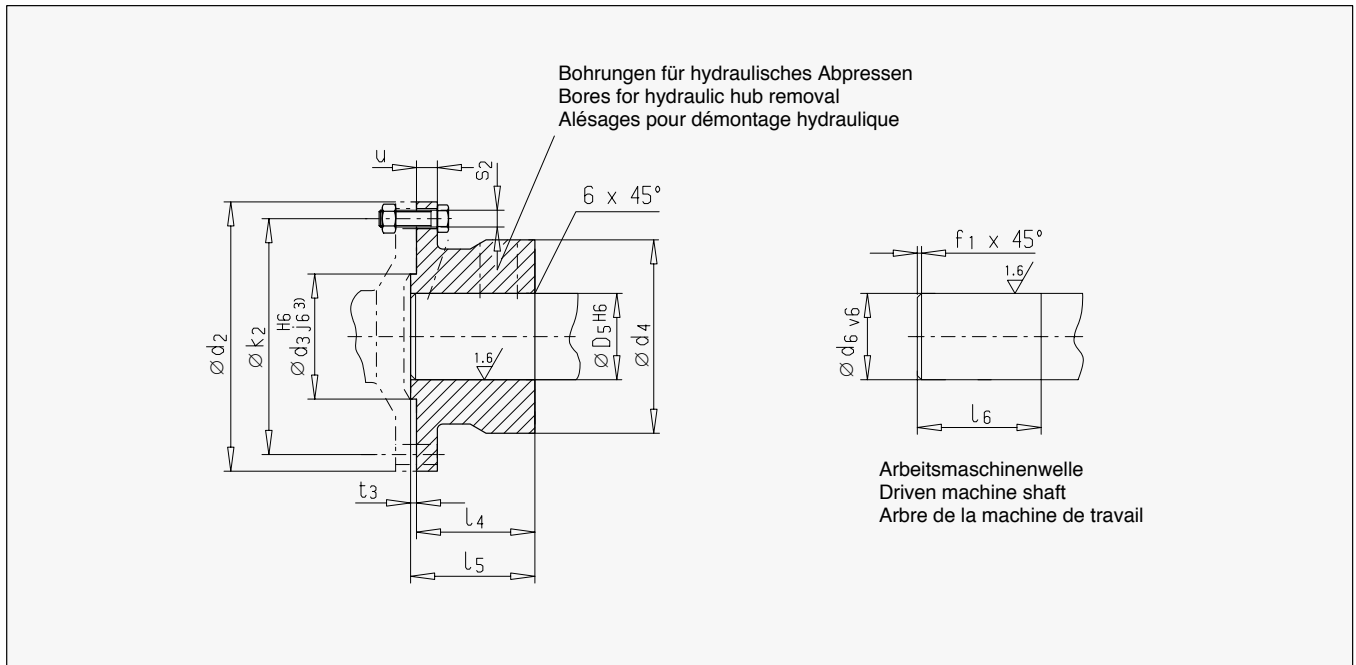

Bauarten / Types **H2F., H3F., H4F., B2F., B3F., B4F.**

Getriebe- größe Gear unit size Taille réducteur	Flansch / Flange / Bride										Schraube 1) Bolt / Vis			Arbeitsmaschinen- welle Driven machine shaft Arbre de la machine de travail			Gewicht Weight Poids  kg
	d <sub>2</sub>	d <sub>3</sub>	d <sub>4</sub>	2) D <sub>5</sub>	k <sub>2</sub>	l <sub>4</sub>	l <sub>5</sub>	s <sub>2</sub>	t <sub>3</sub>	u	Größe Size Taille	Anzahl Qty. Qté	T <sub>a</sub> Nm	d <sub>6</sub>	f <sub>1</sub>	l <sub>6</sub>	
	mm													mm			
<b>13</b>	580	310	390	240	500	310	322	M 30	12	48	M 30 x 130	20	2100	240	3	322	235
<b>14</b>	620	310	425	260	540	345	357	M 30	12	48	M 30 x 130	24	2100	260	3	357	300
<b>15</b>	710	360	460	280	630	365	380	M 30	15	55	M 30 x 140	28	2100	280	3	380	400
<b>16</b>	740	360	480	300	660	395	410	M 30	15	55	M 30 x 140	30	2100	300	4	410	450
<b>17</b>	750	410	520	320	660	420	436	M 36	16	60	M 36 x 160	24	3560	320	4	436	540
<b>18</b>	800	410	550	340	710	450	466	M 36	16	60	M 36 x 160	26	3560	340	4	466	650
<b>19 - 26</b>	Auf Anfrage / On request / Sur demande																

1) Schrauben nach DIN 931, Werkstoff 10.9;  
Mutter nach DIN 934, Werkstoff 10.

2) Andere Durchmesser auf Anfrage. (Bei Fuß-  
ausführung sind kleinere Bohrungen D<sub>5</sub> mög-  
lich).

3) Maß d<sub>3</sub> j6 nach dem Aufschrumpfen.  
Flanschverbindung mit Paßfedernut auf Anfrage.

Werkstoffe der Flansche und Arbeitsmaschinen-  
wellen C60N oder höhere Festigkeiten.

Gegenflansch beim Aufsetzen auf 190 °C er-  
wärmen, Arbeitsmaschinenwelle auf 20 °C.

1) Bolts acc. to DIN 931, material 10.9;  
Nuts acc. to DIN 934, material 10.

2) Other diameters on request. (For foot-mount-  
ed design, smaller bores D<sub>5</sub> are possible).

3) Dimension d<sub>3</sub> j6 after shrink fitting.  
Counterflange with keyway on request.

Material of flanges and driven machine shafts:  
C60N or higher strengths.

For assembly, heat counterflange to 190 °C, and  
driven machine shaft to 20 °C.

1) Vis selon DIN 931, matière 10.9;  
Écrous selon DIN 934, matière 10.

2) Autres diamètres sur demande. (Petits alésa-  
ges possibles pour la version avec patte).

3) Dimension d<sub>3</sub> j6 après le frettage.

Raccord de la bride avec rainure de clavette sur  
demande.

Matières des brides et arbres de la machine de  
travail C60N ou meilleure résistance.

Lors de l'installation, préchauffez la contre-bride à  
190 °C, l'arbre de la machine de travail à 20 °C.

## Ölauswahl und Konservierung

## Selection of Oil and Preservation

## Sélection du type d'huile Conservation

FLENDER-Zahnradgetriebe können mit Ölen von Flender zugelassener Hersteller befüllt werden, wobei der Ölhersteller bzw. Öllieferant für die Qualität seines Produktes verantwortlich ist. Bei der Auswahl von Ölsorte und Ölviskosität sind die in der Tabelle 1 genannten Einsatzgrenzen zu beachten.

Die Tabelle 2 gibt einen Überblick über die möglichen Ölversorgungsvarianten für die entsprechenden Bauarten und Größen.

Eine Mindest-Betriebsviskosität von 25 cSt muß gewährleistet sein.

FLENDER gear units may be filled with oils from producers authorized by Flender, the oil producer or supplier being responsible for the quality of his product. For the selection of oil grade and viscosity, the limits of application given in table 1 are to be taken into consideration.

In table 2 a survey of the possible oil supply variants is given for the respective types and sizes.

A minimum operating viscosity of 25 cSt must be ensured.

Les réducteurs FLENDER sont à remplir avec une huile avalisée par Flender, le fabricant et/ou le fournisseur de l'huile restant responsable de la qualité de son produit. Pour le choix du type et de la viscosité de l'huile tenir compte des limites indiquées dans le tableau 1.

Le tableau 2 donne un aperçu des variantes de lubrification pour les types et tailles réducteurs.

Une viscosité de fonctionnement minimale de 25 cSt doit être garantie.

Tabelle / Table / Tableau 1				
Viskosität ISO-VG bei 40 °C in mm <sup>2</sup> /s (cSt) Viscosity ISO-VG at 40 °C in mm <sup>2</sup> /s (cSt) Viscosité ISO-VG à 40 °C en mm <sup>2</sup> /s (cSt)	minimale Grenztemperaturen in °C für Minimum temperature limit in °C for Températures limites inférieures en °C pour			
	Tauchschmierung Dip lubrication Lubrification par barbotage		Druckschmierung Forced lubrication Lubrification sous pression	
	Mineralöl Mineral oil Huile minérale	Synthetisches Öl Synthetic oil Huile synthétique	Mineralöl Mineral oil Huile minérale	Synthetisches Öl Synthetic oil Huile synthétique
<b>VG 220</b>	- 15	- 25	10	0
<b>VG 320</b>	- 12	- 25	15	5
<b>VG 460</b>	- 9	- 25	-	-

### Tauchschmierung:

Bei Tauchschmierung liegen alle zu schmierenen Elemente in Öl.

Ein Ölausgleichsbehälter ist für die Ölausdehnung angeschraubt.

Auswahlkriterien siehe Seite 138

Unterhalb der in der Tabelle angegebenen Temperaturen muß beheizt werden.

Bei Tauchschmierung darf die Öltemperatur nicht unterhalb des Pourpoints des gewählten Öles liegen.

### Druckschmierung:

Bei Druckschmierung werden alle nicht in Öl liegenden Elemente durch eine angebaute Flanschpumpe oder durch eine separate Motorpumpe mit Spritzöl versorgt.

Auswahlkriterien siehe Seiten 139 - 142

Bei Druckschmierung darf die Betriebsviskosität 1800 cSt beim Anfahren nicht überschritten werden.

Unterhalb der in Tabelle 1 aufgeführten Grenztemperaturen ist Tauchschmierung vorzusehen oder es muß beheizt werden.

### Dip lubrication:

In case of dip lubrication, all parts to be lubricated are lying in the oil.

An oil compensating tank has been fitted for oil expansion.

For criteria for selection, see page 138.

If the temperatures are below the values as listed in the table, the oil must be heated.

In case of dip lubrication, the oil temperature must not drop below the pour point of the selected oil.

### Forced lubrication:

In case of forced lubrication, all parts not lying in oil are splash lubricated by means of a flanged-on pump or by a separate motor pump.

For criteria for selection, see pages 139 - 142.

In case of forced lubrication, the operating viscosity 1800 cSt must not be exceeded during start-up.

If the temperatures are below the values as listed in table 1, dip lubrication has to be provided or the oil must be heated.

### Lubrification par barbotage:

Lors de la lubrification par barbotage, tous les éléments à graisser sont plongés dans l'huile.

Un réservoir de compensation d'huile est vissé pour la dilatation de l'huile.

Critères de sélection, voir page 138

Il doit y avoir préchauffage de l'huile lors de températures inférieures à celles indiquées dans le tableau.

Lors de la lubrification par barbotage, la température de l'huile ne doit pas descendre en-dessous du point d'écoulement de l'huile sélectionnée.

### Lubrification sous pression:

Lors de la lubrification sous pression, tous les éléments ne se trouvant pas dans l'huile sont alimentés en huile par une pompe flasquée intégrée ou par une pompe à moteur séparé.

Critères de sélection, voir pages 139 - 142

Lors de la lubrification sous pression, la viscosité de fonctionnement ne doit pas dépasser 1800 cSt lors du démarrage.

Prévoir la lubrification par barbotage ou procéder au préchauffage à des températures inférieures à celles indiquées dans le tableau 1.

### Konservierung:

Die Innenkonservierung von FLENDER-Zahnradgetrieben ist abhängig von dem zum Einsatz kommenden Öl.

Für konservierte Getriebe sind folgende Lagerzeiten möglich:

Standard-Konservierung	Langzeit-Konservierung <sup>1)</sup>
bis 6 Monate	bis 24 Monate <sup>2)</sup> bis 36 Monate <sup>3)</sup>

1) nicht für Getriebe mit Labyrinth- oder Spaltdichtung.

2) nur bei Einsatz von Mineralöl oder synthetischem Öl auf PAO-Basis.

3) nur bei Einsatz von synthetischem Öl auf PG-Basis.

Bei Überschreitung der genannten Lagerzeiten ist das Getriebe erneut zu konservieren.

### Preservation:

The internal preservation of FLENDER gear units is dependent on the oil used.

For gear units with corrosion prevention, the following storage times are possible:

Standard preservation	Long-term preservation <sup>1)</sup>
up to 6 months	up to 24 months <sup>2)</sup> up to 36 months <sup>3)</sup>

1) Not for gear units with labyrinth seals or diaphragm glands.

2) Only if mineral oil or synthetic oil on PAO basis is used.

3) Only if synthetic oil on PG basis is used.

If the storage periods mentioned are exceeded, the anti-corrosive agent in the gear unit is to be renewed.

### Conservation:

Le type de conservation intérieure des réducteurs est dépendant de l'huile qui sera employé lors de leur utilisation.

Il est possible de conserver les réducteurs pour les temps de stockage suivants:

Conservation standard	Conservation longue <sup>1)</sup>
jusqu'à 6 mois	jusqu'à 24 mois <sup>2)</sup> jusqu'à 36 mois <sup>3)</sup>

1) Non applicable pour les réducteurs à joints labyrinthe ou sans contact.

2) Seulement pour l'emploi ultérieur d'huile minérale ou synthétique sur base PAO.

3) Seulement pour l'emploi ultérieur d'huile synthétique sur base PG.

En cas de prolongement du temps de stockage du réducteur un nouveau conditionnement de conservation sera nécessaire.

## Zahnradgetriebe

Ölversorgung

Variantenübersicht

Bauarten H2, H3, H4, B2, B3, B4

Größen 3 - 26

## Gear Units

Oil Supply

Survey of Variants

Types H2, H3, H4, B2, B3, B4

Sizes 3 - 26

## Réducteurs à engrenages

Alimentation en huile

Aperçu des variantes

Types H2, H3, H4, B2, B3, B4

Tailles 3 - 26

Tabelle / Table / Tableau 2							
Bauart Type	Größe Size Taille	Tauchschmierung Dip lubrication Lubrification par barbotage		Druckschmierung Flanschpumpe Forced lubrication, flanged-on pump Lubrification sous pression par pompe flasquée		Druckschmierung Motorpumpe Forced lubrication, motor pump Lubrification sous pression par moto-pompe	
H1SH	3 - 17	H		H		-	
H2..	4	H V		V		-	
	5 - 12	H V		H V SR <sup>1) 3)</sup>		-	
	13 - 18	H M		H M V SR <sup>1) 3)</sup>		-	
	19 - 26	H M		V		-	
H3..	5 - 12	H V		V SR <sup>1)</sup>		V SR <sup>1)</sup>	
	13 - 18	H M		V SR <sup>1)</sup>		V SR <sup>1)</sup>	
	19 - 26	H M		V		-	
H4..	7 - 12	H V		V		V	
	13 - 18	H M		V		V	
	19 - 26	H M		V		-	
B2..	4	H V		V		-	
	5 - 12	H V		H V SR <sup>2)</sup>		V SR <sup>2)</sup>	
	13 - 18	H M		H M V SR <sup>2)</sup>		V SR <sup>2)</sup>	
	19 - 26	H M		V		-	
B3..	4	H V		V		-	
	5 - 12	H V		V SR <sup>2)</sup>		V SR <sup>2)</sup>	
	13 - 18	H M		V SR <sup>2)</sup>		V SR <sup>2)</sup>	
	19 - 26	H M		V		-	
B4..	5 - 12	H V		V SR <sup>2)</sup>		V SR <sup>2)</sup>	
	13 - 18	H M		V SR <sup>2)</sup>		V SR <sup>2)</sup>	
	19 - 26	H M		V		-	

**H** = Horizontalgetriebe

**M** = Horizontalgetriebe in Aufsteckausführung

**V** = Vertikalgetriebe

**SR** = Vertikalgetriebe mit Abtriebsvollwelle und Ölstaurohr

**H** = Horizontal gear unit

**M** = Shaft-mounted horizontal gear unit

**V** = Vertical gear unit

**SR** = Vertical gear unit with solid output shaft and oil retaining tube

**H** = Réducteur horizontal

**M** = Réducteur horizontal flottant

**V** = Réducteur verticaux

**SR** = Réducteur verticaux avec arbre de sortie plein et cheminée de retenue d'huile

1) Nur Ausführung B möglich

2) Nur Ausführung C möglich

3) Größe 5 nur bis  $i \leq 16$  möglich

Größe 7 nur bis  $i \leq 16$  möglich

Größe 11 nur bis  $i \leq 18$  möglich

Größe 13 nur bis  $i \leq 18$  möglich

Größe 17 nur bis  $i \leq 16$  möglich

1) Design B possible only

2) Design C possible only

3) For size 5 only possible up to  $i \leq 16$

For size 7 only possible up to  $i \leq 16$

For size 11 only possible up to  $i \leq 18$

For size 13 only possible up to  $i \leq 18$

For size 17 only possible up to  $i \leq 16$

1) Exécution B seulement possible

2) Exécution C seulement possible

3) Pour taille 5 seulement possible  $i \leq 16$

Pour taille 7 seulement possible  $i \leq 16$

Pour taille 11 seulement possible  $i \leq 18$

Pour taille 13 seulement possible  $i \leq 18$

Pour taille 17 seulement possible  $i \leq 16$

## Zahnradgetriebe

Tauchschmierung

Vertikal

Bauarten H2, H3, H4, B2, B3, B4

Größen 4 - 12

## Gear Units

Dip lubrication

Vertical

Types H2, H3, H4, B2, B3, B4

Sizes 4 - 12

## Réducteurs à engrenages

Lubrification par barbotage

Vertical

Types H2, H3, H4, B2, B3, B4

Tailles 4 - 12

Bei der Auslegung der Tauchschmierung sind folgende Kriterien zu berücksichtigen:

- maximale Eingangsdrehzahl  $n_1$  siehe Tabelle 3
- zulässige Öltemperaturen siehe Tabelle 1

Bei Getrieben mit  $n_1$  und  $i_N$ , die nicht in der Tabelle 3 aufgeführt sind, kann die thermische Auslegung von den in diesem Katalog genannten Parametern abweichen. Gegebenenfalls sind diese Getriebe mit einer Druckschmierung auszuführen. Hier ist Rücksprache mit Flender notwendig!

For the design with dip lubrication the following criteria are to be taken into account:

- For maximum input speed  $n_1$ , see table 3.
- For permissible oil temperatures, see table 1.

For gear units with  $n_1$  and  $i_N$  not listed in table 3, the parameters for the calculation of the thermal capacity can deviate from those given in this brochure. If necessary, such gear units are to be designed with forced lubrication. Please consult Flender!

Lors de la conception de la lubrification par barbotage, respecter les critères suivants:

- Vitesse d'entrée maximale  $n_1$ , voir tableau 3
- Températures de l'huile autorisées, voir tableau 1

Pour des réducteurs pour lesquels  $n_1$  et  $i_N$  ne sont pas indiqués dans le tableau N° 3, les paramètres pour le calcul thermique peuvent ne pas correspondre à ceux indiqués dans ce catalogue. Si nécessaire, ces réducteurs doivent être prévus avec une lubrification forcée. Veuillez consulter Flender!

Tabelle / Table / Tableau 3

Größe Size Taille	Bauarten / Types											
	H2.V		H3.V		H4.V		B2.V		B3.V		B4.V	
	$i_N$	$n_{1max}$	$i_N$	$n_{1max}$	$i_N$	$n_{1max}$	$i_N$	$n_{1max}$	$i_N$	$n_{1max}$	$i_N$	$n_{1max}$
4	6.3 - 10	1200	-		-	-	5 - 5.6	750	12.5 - 71	1800	-	
	11.2 - 12.5	1500					6.3 - 7.1	900				
	14 - 22.4	1800					8 - 9	1000				
							10 - 11.2	1200				
5	6.3 - 9	1000	25 - 90	1800	-	-	6.3 - 7.1	750	12.5 - 71	1800	80 - 315	1800
	10 - 12.5	1200					8 - 9	900				
	14 - 16	1500					10 - 11.2	1000				
	18 - 22.4	1800										
6	8 - 11.2	1000	31.5 - 112	1800	-	-	9	750	16 - 90	1800	100 - 400	1800
	12.5 - 16	1200					10 - 11.2	900				
	18 - 20	1500					12.5 - 14	1000				
	22.4 - 28	1800										
7	6.3 - 7.1	750	25 - 90	1800	100 - 355	1800	9 - 10	750	12.5 - 25	1500	80 - 315	1800
	8 - 9	900					11.2	900				
	10 - 11.2	1000										
	12.5 - 16	1200										
18 - 22.4	1500											
8	8 - 9	750	31.5 - 112	1800	125 - 450	1800	11.2 - 12.5	750	16 - 31.5	1500	100 - 400	1800
	10 - 11.2	900					14	900				
	12.5 - 14	1000					35.5 - 90	1800				
	16 - 20	1200										
22.4 - 28	1500											
9	6.3 - 7.1	1200	25 - 90	1800	100 - 355	1800	5 - 5.6	900	12.5 - 71	1800	80 - 315	1800
	8 - 10	1500					6.3 - 7.1	1000				
	11.2 - 22.4	1800					8 - 10	1200				
							11.2	1500				
10	8 - 9	1200	31.5 - 112	1800	125 - 450	1800	6.3 - 7.1	900	16 - 90	1800	100 - 400	1800
	10 - 12.5	1500					8 - 9	1000				
	14 - 28	1800					10 - 12.5	1200				
							14	1500				
11	6.3 - 7.1	1000	25 - 90	1800	100 - 355	1800	5.6 - 6.3	750	12.5 - 22.4	1500	80 - 315	1800
	8 - 10	1200					7.1 - 8	900				
	11.2 - 12.5	1500					9 - 10	1000				
	14 - 22.4	1800					11.2	1200				
12	8 - 9	1000	31.5 - 112	1800	125 - 450	1800	7.1 - 8	750	16 - 28	1500	100 - 400	1800
	10 - 12.5	1200					9 - 10	900				
	14 - 16	1500					11.2 - 12.5	1000				
	18 - 28	1800					14	1200				

**Zahnradgetriebe**

Druckschmierung  
Flanscpumpe  
Bauarten H2.V, H3.V, H4.V  
Größen 5 - 18 Vertikal

**Gear Units**

Forced Lubrication  
Flanged-on Pump  
Types H2.V, H3.V, H4.V  
Sizes 5 - 18 Vertikal

**Réducteurs à engrenages**

Lubrification sous pression  
Pompe flasquée  
Types H2.V, H3.V, H4.V  
Tailles 5 - 18 Vertikal

Tabelle / Table / Tableau 4								
Flanscpumpenzuordnung für Stirnrad-Vertikalgetriebe / Assignment of flanged-on pumps to vertical helical gear units Correspondances des pompes flasquée pour réducteurs verticaux à engrenages cylindriques								
Bauart Type Ausführung Design Exécution	n <sub>1</sub> min <sup>-1</sup>	Getriebegröße Gear unit size Taille réducteur		Flansch- pumpengröße Flanged-on pump size Taille de la pompe flasquée	Getriebegröße Gear unit size Taille réducteur			Flansch- pumpengröße Flanged-on pump size Taille de la pompe flasquée
		5, 7, 9, 11	6, 8, 10, 12		13, 15, 17	14	16, 18	
		Übersetzung / Ratio / Rapport i <sub>N</sub>			Übersetzung / Ratio / Rapport i <sub>N</sub>			
H2.V A, C	750 - 1800	6.3 - 22.4	8 - 28	KSW 1	6.3 - 22.4	8 - 28	7.1 - 25	KSW 2
H3.V A, C	1201 - 1800	25 - 40	31.5 - 50	KSW 2	22.4 - 50	28 - 63	25 - 56	KSW 3
		45 - 90	56 - 112	KSW 3	56 - 90	71 - 112	63 - 90	KSW 4
							100	*
	901 - 1200	25 - 56	31.5 - 71	KSW 3	22.4 - 31.5	28 - 40	25 - 35.5	KSW 3
		63 - 90	80 - 112	*	35.5 - 56	45 - 71	40 - 63	KSW 4
					63 - 90	80 - 112	71 - 100	*
	750 - 900	25 - 45	31.5 - 56	KSW 3	22.4 - 25	28 - 31.5	25 - 28	KSW 3
		50 - 90	63 - 112	*	28 - 45	35.5 - 56	31.5 - 50	KSW 4
				50 - 90	63 - 112	56 - 100	*	
H4.V A, C	1201 - 1800	100 - 224	125 - 280	KSW 3	100 - 355	125 - 450	112 - 400	*
		250 - 355	315 - 450	*				
	901 - 1200	100 - 140	125 - 180	KSW 3				
		160 - 355	200 - 450	*				
	750 - 900	100 - 112	125 - 140	KSW 3				
		125 - 355	160 - 450	*				
H2.V B, D	750 - 1800	6.3 - 22.4	8 - 28	KSW 1	6.3 - 22.4	8 - 28	7.1 - 25	KSW 2
H3.V B, D	1201 - 1800	25 - 35.5	31.5 - 45	KSW 2	22.4 - 35.5	28 - 45	25 - 40	KSW 3
		40 - 71	50 - 90	KSW 3	40 - 71	50 - 90	45 - 80	KSW 4
		80 - 90	100 - 112	*	80 - 90	100 - 112	90 - 100	*
	901 - 1200	25 - 50	31.5 - 63	KSW 3	22.4 - 25	28 - 31.5	25 - 28	KSW 3
		56 - 90	71 - 112	*	28 - 45	35.5 - 56	31.5 - 50	KSW 4
					50 - 90	63 - 112	56 - 100	*
	750 - 900	25 - 35.5	31.5 - 45	KSW 3	22.4 - 35.5	28 - 45	25 - 40	KSW 4
		40 - 90	50 - 112	*	40 - 90	50 - 112	45 - 100	*
H4.V B, D	1201 - 1800	100 - 180	125 - 224	KSW 3	100 - 355	125 - 450	112 - 400	*
		200 - 355	250 - 450	*				
	901 - 1200	100 - 125	125 - 160	KSW 3				
		140 - 355	180 - 450	*				
	750 - 900	100 - 355	125 - 450	*				

\* = Motorpumpe erforderlich siehe Tabelle 6 / Motor pump required, see table 6 / Motopompe nécessaire, voir tableau 6

**Zahnradgetriebe**

Druckschmierung  
Flanscpumpe  
Bauarten B2.V, B3.V, B4.V  
Größen 5 - 18 Vertikal

**Gear Units**

Forced Lubrication  
Flanged-on Pump  
Types B2.V, B3.V, B4.V  
Sizes 5 - 18 Vertikal

**Réducteurs à engrenages**

Lubrification sous pression  
Pompe flasquée  
Types B2.V, B3.V, B4.V  
Tailles 5 - 18 Vertikal

Tabelle / Table / Tableau 5								
Flanscpumpenzuordnung für Kegelstirnrad-Vertikalgetriebe / Assignment of flanged-on pumps to vertical bevel-helical gear units Correspondances pompes flasquées pour réducteurs verticaux à engrenages cylindro-coniques								
Bauart Type Ausführung Design Exécution	n <sub>1</sub> min <sup>-1</sup>	Getriebegröße Gear unit size Taille réducteur		Flansch- pumpengröße Flanged-on pump size Taille de la pompe flasquée	Getriebegröße Gear unit size Taille réducteur			Flansch- pumpengröße Flanged-on pump size Taille de la pompe flasquée
		5, 7, 9, 11	6, 8, 10, 12		13, 15, 17	14	16, 18	
		Übersetzung / Ratio / Rapport i <sub>N</sub>						
B2.V A, B	1201 - 1800	5 - 6.3	6.3 - 8	KSW 1	5 - 8	6.3 - 10	5.6 - 9	KSW 2
		7.1 - 11.2	9 - 14	KSW 2	9 - 11.2	11.2 - 14	10 - 12.5	KSW 3
	901 - 1200	5 - 8	6.3 - 10	KSW 2	5	6.3	5.6	KSW 2
		9 - 11.2	11.2 - 14	KSW 3	5.6 - 11.2	7.1 - 14	6.3 - 12.5	KSW 3
	750 - 900	5 - 6.3	6.3 - 8	KSW 2	5 - 10	6.3 - 12.5	5.6 - 11.2	KSW 3
		7.1 - 10	9 - 12.5	KSW 3	11.2	14	12.5	*
		11.2	14	*				
B2.V C, D	1201 - 1800	5 - 6.3	6.3 - 8	KSW 1	5 - 6.3	6.3 - 8	5.6 - 7.1	KSW 2
		7.1 - 11.2	9 - 14	KSW 2	7.1 - 11.2	9 - 14	8 - 12.5	KSW 3
	901 - 1200	5 - 8	6.3 - 10	KSW 2	5 - 10	6.3 - 12.5	5.6 - 11.2	KSW 3
		9 - 11.2	11.2 - 14	KSW 3	11.2	14	12.5	*
	750 - 900	5 - 6.3	6.3 - 8	KSW 2	5 - 7.1	6.3 - 9	5.6 - 8	KSW 3
		7.1 - 10	9 - 12.5	KSW 3	8 - 11.2	10 - 14	9 - 12.5	*
		11.2	14	*				
B3.V A, B	1201 - 1800	12.5 - 35.5	16 - 45	KSW 2	12.5 - 22.4	16 - 28	14 - 25	KSW 2
		40 - 71	50 - 90	KSW 3	25 - 50	31.5 - 63	28 - 56	KSW 3
					56 - 71	71 - 90	63 - 80	KSW 4
	901 - 1200	12.5 - 25	16 - 31.5	KSW 2	12.5 - 35.5	16 - 45	14 - 40	KSW 3
		28 - 50	35.5 - 63	KSW 3	40 - 56	50 - 71	45 - 63	KSW 4
		56 - 71	71 - 90	*	63 - 71	80 - 90	71 - 80	*
750 - 900	12.5 - 35.5	16 - 45	KSW 3	12.5 - 25	16 - 31.5	14 - 28	KSW 3	
	40 - 71	50 - 90	*	28 - 40	35.5 - 50	31.5 - 45	KSW 4	
				45 - 71	56 - 90	50 - 80	*	
B3.V C, D	1201 - 1800	12.5 - 35.5	16 - 45	KSW 2	12.5 - 35.5	16 - 45	14 - 40	KSW 3
		40 - 71	50 - 90	KSW 3	40 - 71	50 - 90	45 - 80	KSW 4
	901 - 1200	12.5 - 25	16 - 31.5	KSW 2	12.5 - 25	16 - 31.5	14 - 28	KSW 3
		28 - 50	35.5 - 63	KSW 3	28 - 50	35.5 - 63	31.5 - 56	KSW 4
		56 - 71	71 - 90	*	56 - 71	71 - 90	63 - 80	*
750 - 900	12.5 - 35.5	16 - 45	KSW 3	12.5 - 35.5	16 - 45	14 - 40	KSW 4	
	40 - 71	50 - 90	*	40 - 71	50 - 90	45 - 80	*	
B4.V A, B	1201 - 1800	80 - 125	100 - 160	KSW 2	80 - 315	100 - 400	90 - 355	*
		140 - 250	180 - 315	KSW 3				
		280 - 315	355 - 400	*				
	901 - 1200	80 - 180	100 - 224	KSW 3				
		200 - 315	250 - 400	*				
		750 - 900	80 - 125	100 - 160				
140 - 315	180 - 400		*					
B4.V C, D	1201 - 1800	80 - 180	100 - 224	KSW 3	80 - 315	100 - 400	90 - 355	*
		200 - 315	250 - 400	*				
		901 - 1200	80 - 125	100 - 160				
	140 - 315		180 - 400	*				
	750 - 900		80 - 90	100 - 112				
		100 - 315	125 - 400	*				

\* = Motorpumpe erforderlich siehe Tabelle 7 / Motor pump required, see table 7 / Motopompe nécessaire, voir tableau 7



**Zahnradgetriebe**

Druckschmierung  
 Motorpumpe  
 Bauarten H2, H3, H4, B2, B3, B4  
 Größen 5 - 18 Vertikal

**Gear Units**

Forced Lubrication  
 Motor Pump  
 Types H2, H3, H4, B2, B3, B4  
 Sizes 5 - 18 Vertical

**Réducteurs à engrenages**

Lubrification sous pression  
 Motopompe  
 Types H2, H3, H4, B2, B3, B4  
 Tailles 5 - 18 Vertikal

Tabelle / Table / Tableau 6			
Motorpumpenzuordnung für Stirnrad-Vertikalgetriebe / Assignment of motor pumps to vertical helical gear units Motopompes correspondantes pour réducteurs verticaux à engrenages cylindriques			
Bauart / Type	Größe / Size / Taille	Ausführung / Design / Exécution	Pumpe / Pump / Pompe
H2.V	5 - 18	A / B / C / D	1)
H3.V	5 - 18	A / C	SF 2/8
	5 - 12	B / D	SF 2/8
	13 - 18		SF 2/13
H4.V	7 - 12	A / C	SF 2/8
	13 - 18		SF 2/13
	7 - 18	B / D	SF 2/13

1) nur Flanscpumpe

1) Flanged-on pump only

1) pompe flasquée

Tabelle / Table / Tableau 7			
Motorpumpenzuordnung für Kegelstirnrad-Vertikalgetriebe / Assignment of motor pumps to vertical bevel-helical gear units Motopompes correspondantes pour réducteurs verticaux à engrenages cylindro-coniques			
Bauart / Type	Größe / Size / Taille	Ausführung / Design / Exécution	Pumpe / Pump / Pompe
B2.V	5 - 12	A / B	SF 2/5
	13 - 18		SF 2/8
	5 - 18	C / D	SF 2/8
B3.V	5 - 12	A / B	SF 2/8
	13 - 18		SF 2/13
	5 - 12	C / D	SF 2/8
	13 - 18		SF 2/13
B4.V	5 - 12	A / B	SF 2/8
	13 - 18		SF 2/13
	5 - 12	C / D	SF 2/8
	13 - 18		SF 2/13

## Zahnradgetriebe

Druckschmierung  
Überwachungsgeräte  
Bauarten H2, H3, H4, B2, B3, B4  
Größen 5 - 18 Vertikal

## Gear Units

Forced Lubrication  
Monitoring Instruments  
Types H2, H3, H4, B2, B3, B4  
Sizes 5 - 18 Vertikal

## Réducteurs à engrenages

Lubrification sous pression  
Dispositifs de contrôle  
Types H2, H3, H4, B2, B3, B4  
Tailles 5 - 18 Vertikal

Überwachungsgeräte bei Druckschmierung durch Flansch- oder Motorpumpe

Monitoring instruments for forced lubrication by means of flanged-on or motor pump

Dispositifs de contrôle lors du graissage sous pression par pompe à bride ou par motopompe

Getriebegröße Gear unit size Taille réducteur 5 - 12	Getriebegröße Gear unit size Taille réducteur 13 - 18
a) Grobfilter Coarse filter Gros filtre	a) Doppelschaltfilter Double change-over filter Filtre double
b) Druckwächter Pressure monitor Capteur de pression	b) Druckwächter Pressure monitor Capteur de pression
	c) Anschluß für Manometer G 1/2 Connection for pressure gauge G 1/2 Raccord pour manomètre G 1/2

**a)**  
**Grobfilter** dienen dem Schutz von nachgeschalteten Aggregaten durch Auffangen und Sammeln von Schmutzpartikeln.

**a)**  
**Coarse filters** serve to protect downstream units by catching and collecting dirt particles.

**a)**  
Les **gros filtres** servent à protéger les éléments intercalés à la suite en récupérant et en rassemblant les particules de saleté.

**Doppelschaltfilter** in Boxer-Ausführung haben eine optisch/elektrische Verschmutzungsanzeige.  
Differenzdruck  $\Delta p = 2$  bar, 1 Umschaltkontakt.

**Double change-over filters** with opposed cylinders have an opto-electrical contamination indicator.  
Differential pressure  $\Delta p = 2$  bar; 1 change-over contact.

Les **filtres doubles** en exécution opposée disposent d'un indicateur optique/électrique du colmatage.  
Pression différentielle  $\Delta p = 2$  bars, 1 contact de commutation.

Elektrische Grenzdaten:  
Schaltspannung  $U \leq 250$  V DC + AC  
Schaltstrom  $I \leq 1$  A  
Schaltvermögen  $P \leq 30$  W bzw.  $\leq 60$  VA  
Schutzart IP 65

Electrical maximum ratings:  
Switching voltage  $U \leq 250$  V DC + AC  
Switching current  $I \leq 1$  A  
Switching capability  $P \leq 30$  W or  $\leq 60$  VA  
Type of protection IP 65

Données électriques maximales:  
Tension de commutation  $U \leq 250$  V DC + AC  
Courant  $I \leq 1$  A  
Capacité de commutation  $P \leq 30$  W ou  $\leq 60$  VA  
Type de protection IP 65

**b)**  
Der **Druckwächter** kann in Verbindung mit einer Warnanlage das Absinken des Öldruckes  $\leq 0,5$  bar optisch oder akustisch anzeigen oder die Anlage ausschalten.

**b)**  
When the oil pressure drops below 0.5 bar, the **pressure monitor** in combination with a warning system can give an optical or acoustical warning, or switch off the system.

**b)**  
En cas de baisse de pression d'huile en dessous de 0,5 bar, le **capteur de pression** en liaison avec un dispositif d'alarme peut fournir un signal optique ou acoustique, ou bien arrêter l'installation.

**Technische Daten:**  
Max. Schaltleistungen  
2 A/250 V, AC/250 VA (Wechselspannung)  
4 A/200 V, DC/20 W (Gleichspannung)  
Schutzart IP 65

**Technical data:**  
Max. switching capacity  
2 A/250 V; AC/250 VA (alternating current)  
4 A/200 V; DC/20 W (direct current)  
Type of protection IP 65

**Données techniques:**  
Puissance de commutation max  
2 A/250 V, AC/250 VA (courant alternatif)  
4 A/200 V, DC/20 W (courant continu)  
Type de protection IP 65

## Zahnradgetriebe

Druckschmierung  
Horizontal  
Bauart H1SH  
Größen 5 - 17

## Gear Units

Forced Lubrication  
Horizontal  
Type H1SH  
Sizes 5 - 17

## Réducteurs à engrenages

Lubrification sous pression  
Horizontal  
Type H1SH  
Tailles 5 - 17

K20/019



Tabelle / Table / Tableau 9

Getriebegröße Gear unit size Taille réducteur	5	7	9	11	13	15	17		
Pumpe * Pump / Pompe KSW	1	2	2	2	3	3	3	3	3
A mm	≈ 115	≈ 105	≈ 105	≈ 125	≈ 240	≈ 240	≈ 240	≈ 240	≈ 240
E mm	283	337	400	430	474	479	$i_N = 3.15 - 4$ 525	$i_N = 4.5 - 5.6$ 525	$i_N = 2 - 2.8$ 525

\*) Gültig für Drehzahlen:  
 $n_1 \geq 900$  bis  $1800 \text{ min}^{-1}$

\*) Applies to speeds:  
 $n_1 \geq 900$  up to  $1800 \text{ min}^{-1}$

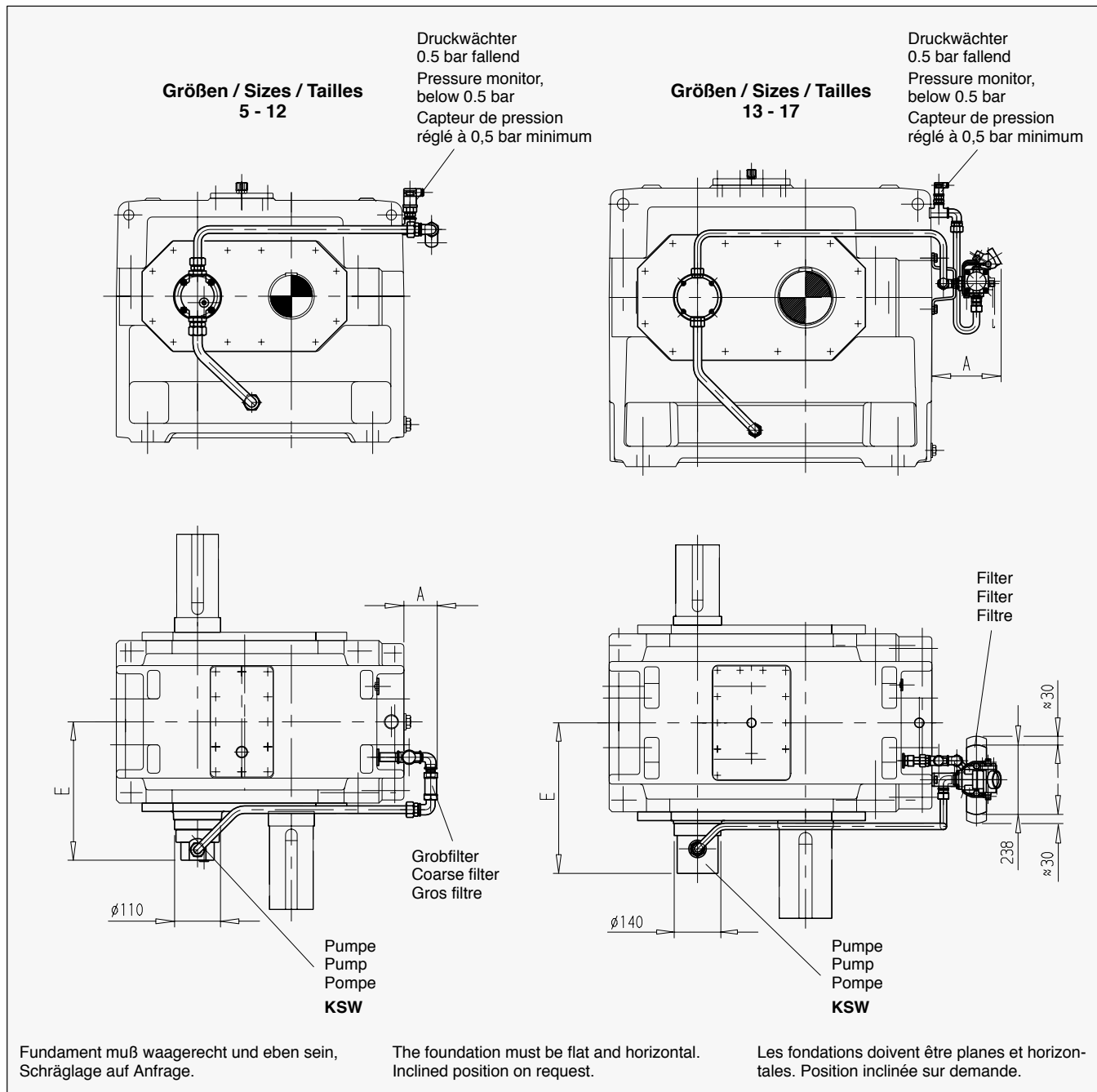
\*) Valable pour vitesses:  
 $n_1 \geq 900$  à  $1800 \text{ min}^{-1}$

## Zahnradgetriebe

Druckschmierung  
Horizontal  
Bauart H2.H  
Größen 5 - 18

## Gear Units

Forced Lubrication  
Horizontal  
Type H2.H  
Sizes 5 - 18

## Réducteurs à engrenages

Lubrification sous pression  
Horizontal  
Type H2.H  
Tailles 5 - 18

K20/019

**Größen / Sizes / Tailles  
5 - 12**

Druckwächter  
0.5 bar fallend  
Pressure monitor,  
below 0.5 bar  
Capteur de pression  
réglé à 0,5 bar minimum

Grobfilter  
Coarse filter  
Gros filtre

Pumpe \*  
Pump  
Pompe  
**KSW 1**

**Größen / Sizes / Tailles  
13 - 18**

Druckwächter  
0.5 bar fallend  
Pressure monitor,  
below 0.5 bar  
Capteur de pression  
réglé à 0,5 bar minimum

Filter  
Filter  
Filtre

Pumpe \*  
Pump  
Pompe  
**KSW 2**

Fundament muß waagrecht und eben sein,  
Schräglage auf Anfrage.

The foundation must be flat and horizontal.  
Inclined position on request.

Les fondations doivent être planes et horizontales.  
Position inclinée sur demande.

**Tabelle / Table / Tableau 10**

Getriebegröße Gear unit size Taille réducteur	5	6	7	8	9	10	11	12	13	14	15	16	17	18
E mm	264		285		308		344		440		475		500	

\*) Gültig für Drehzahlen:  
 $n_1 \geq 1500$  bis  $1800 \text{ min}^{-1}$

\*) Applies to speeds:  
 $n_1 \geq 1500$  up to  $1800 \text{ min}^{-1}$

\*) Valable pour vitesses:  
 $n_1 \geq 1500$  à  $1800 \text{ min}^{-1}$

## Zahnradgetriebe

Druckschmierung  
Horizontal  
Bauart B2SH  
Größen 5 - 18

## Gear Units

Forced Lubrication  
Horizontal  
Type B2SH  
Sizes 5 - 18

## Réducteurs à engrenages

Lubrification sous pression  
Horizontal  
Type B2SH  
Tailles 5 - 18

K20/019

**Größen / Sizes / Tailles**  
5 - 12

Pumpe  
Pump  
Pompe  
**KSW**

**Größen / Sizes / Tailles**  
13 - 18

Pumpe  
Pump  
Pompe  
**KSW**

Fundament muß waagrecht und eben sein,  
Schräglage auf Anfrage.

The foundation must be flat and horizontal.  
Inclined position on request.

Les fondations doivent être planes et horizontales.  
Position inclinée sur demande.

**Tabelle / Table / Tableau 11**

Getriebegröße Gear unit size Taille réducteur	5 / 6			7 / 8			9 / 10			11 / 12			13 / 14		15 / 16		17 / 18	
	1	2	3	1	2	3	1	2	3	1	2	3	2	3	2	3	2	3
Ø N	110	110	140	110	110	140	110	110	140	110	110	140	110	140	110	140	110	140
E	342	342	342	372	372	372	401	401	401	442	442	442	489	489	545	545	606	606

\*) Gültig für folgende Drehzahlen:  
Größen 1 und 2  $n_1 \geq 1500$  bis  $1800 \text{ min}^{-1}$   
Größe 3  $n_1 \geq 1200$  bis  $1800 \text{ min}^{-1}$

\*) Applies to the following speeds:  
Sizes 1 and 2  $n_1 \geq 1500$  up to  $1800 \text{ min}^{-1}$   
Size 3  $n_1 \geq 1200$  up to  $1800 \text{ min}^{-1}$

\*) Valable pour les vitesses suivantes:  
Tailles 1 et 2  $n_1 \geq 1500$  à  $1800 \text{ min}^{-1}$   
Taille 3  $n_1 \geq 1200$  à  $1800 \text{ min}^{-1}$

## Zahnradgetriebe

Wasser-Ölkühler  
Horizontal  
Bauart H1SH  
Größen 5 - 17

## Gear Units

Water-oil Cooler  
Horizontal  
Type H1SH  
Sizes 5 - 17

## Réducteurs à engrenages

Refroidisseur d'huile-eau  
Horizontal  
Type H1SH  
Tailles 5 - 17

K20/020



Tabelle / Table / Tableau 12

Getriebe- größe Gear unit size Taille réducteur	Ölkuhler / Oil cooler / Refroidisseur d'huile												Ölpumpe / Oil pump * Pompe à huile		
	Größe Size Taille	e <sub>1</sub>	e <sub>2</sub>	e <sub>3</sub>	e <sub>4</sub>	e <sub>5</sub>	e <sub>6</sub>	e <sub>7</sub>	h <sub>1</sub>	h <sub>2</sub>	h <sub>3</sub>	h <sub>4</sub>	KSW Größe Size / Taille	d mm	Übersetzung Ratio / Rapport i <sub>ges</sub>
5	01	138	92	170	282	365	342	–	55	95	130	550	1	110	1.25 ... 5.6
7	01	148	102	180	335	405	383	–	90	130	165	570	2	110	1.25 ... 4
					320								1	110	4.5 ... 5.6
9	01	160	114	195	373	450	428	–	140	180	215	620	2	110	1.25 ... 2.8
					373								2	110	3.15 ... 4
					358								1	110	4.5 ... 5.6
11	01	193	147	225	433	510	488	–	185	225	260	665	3	140	1.6 ... 2.8
					433								3	140	3.15 ... 4
					406								2	110	4.5 ... 5.6
13	03	230	160	270	469	610	588	670	75	150	200	938	3	140	1.6 ... 2.8
					469								3	140	3.15 ... 4
					442								2	110	4.5 ... 5.6
15	03	210	140	250	474	685	664	745	95	170	220	958	3	140	2 ... 2.8
					474								3	140	3.15 ... 4
					447								2	110	4.5 ... 5.6
17	03	235	165	275	491	725	704	785	155	230	280	1018	3	140	2 ... 2.8
					491								3	140	3.15 ... 4
					455								2	110	4.5 ... 5.6

Beim Überschreiten der Wärmegrenzleistungen  $P_{GD}$  sind Ölkuhler und Ölpumpe vorzusehen, (evtl. zusammen mit Lüfterbetrieb).

If the thermal capacities  $P_{GD}$  are exceeded, oil cooler and oil pump have to be provided, possibly together with a fan.

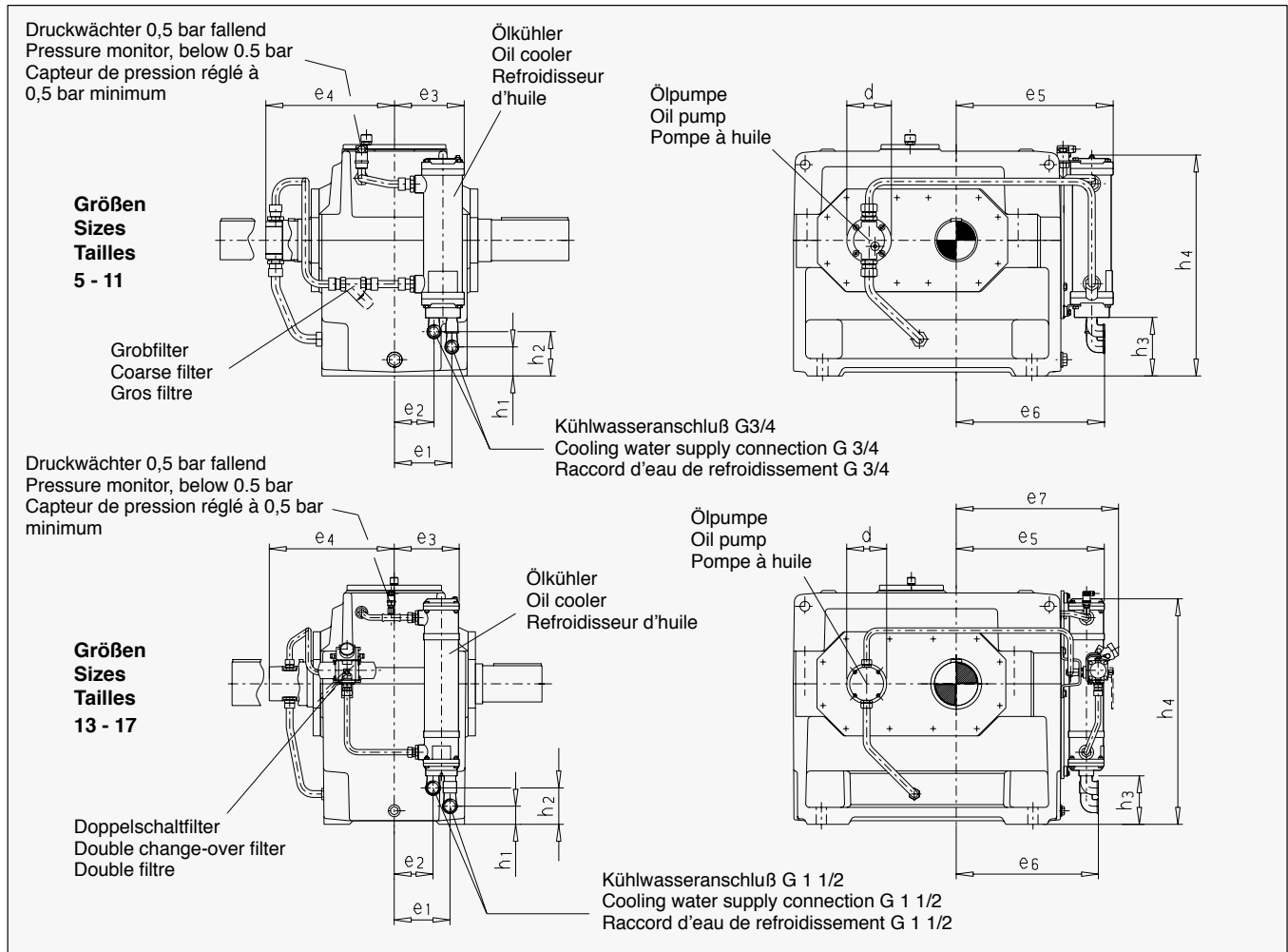
Lors du dépassement des capacités thermiques limites  $P_{GD}$ , prévoir un refroidisseur d'huile et une pompe à huile éventuellement couplés avec un système de refroidissement.

Vertikalgetriebe auf Anfrage

Vertical gear units on request

Réducteurs verticaux sur demande

Wärmegrenzleistungen auf Anfrage

Thermal capacities on request

Capacités thermiques limites sur demande

Kühler geeignet für Süß- und Seewasser

Cooler suitable for fresh and sea water

Refroidisseur adapté à l'eau douce et à l'eau de mer

\*) Gültig für Drehzahlen  $n_1 = 900 - 1800 \text{ min}^{-1}$

\*) Applies to speeds  $n_1 = 900 - 1800 \text{ min}^{-1}$

\*) Valable pour vitesses  $n_1 = 900 - 1800 \text{ min}^{-1}$

## Zahnradgetriebe

Wasser-Ölkühler  
Horizontal  
Bauart H2.H  
Größen 5 - 18

## Gear Units

Water-oil Cooler  
Horizontal  
Type H2.H  
Sizes 5 - 18

## Réducteurs à engrenages

Refroidisseur d'huile-eau  
Horizontal  
Type H2.H  
Tailles 5 - 18

K20/020



Tabelle / Table / Tableau 13

Getriebe- größe Gear unit size Taille réducteur	Ölkühler / Oil cooler / Refroidisseur d'huile												Ölpumpe / Oil pump Pompe à huile *	
	Größe Size Taille	e <sub>1</sub>	e <sub>2</sub>	e <sub>3</sub>	e <sub>4</sub>	e <sub>5</sub>	e <sub>6</sub>	e <sub>7</sub>	h <sub>1</sub>	h <sub>2</sub>	h <sub>3</sub>	h <sub>4</sub>	KSW Größe Size / Taille	d mm
5		123	77	155	263	350	318	—	55	95	130	550		
6	01	123	77	155	263	395	363	—	55	95	130	550	1	110
7		148	102	180	283	395	363	—	75	115	150	570		
8		148	102	180	283	455	423	—	75	115	150	570		
9	01	173	127	205	306	455	413	—	150	190	225	645	1	110
10		173	127	205	306	495	463	—	150	190	225	645		
11	01	203	157	235	342	495	458	—	225	265	300	720	1	
12	01	203	157	235	342	580	543	—	225	265	300	720	2	110
13	03	260	190	300	410	590	563	645	75	150	200	938	2	
14		260	190	300	410	670	633	725	75	150	200	938		
15	03	300	230	340	445	670	643	725	105	180	230	968	2	110
16		300	230	340	445	715	688	770	105	180	230	968		
17						715	683	770						
18	03	330	260	370	475	770	743	825	145	220	270	1008	2	110

\*) Für alle Übersetzungen  
( $n_1 = 750 - 1800 \text{ min}^{-1}$ )

Beim Überschreiten der Wärmegrenzleistungen  $P_{GD}$  sind Ölkühler und Ölpumpe vorzusehen, (evtl. zusammen mit Lüfterbetrieb).

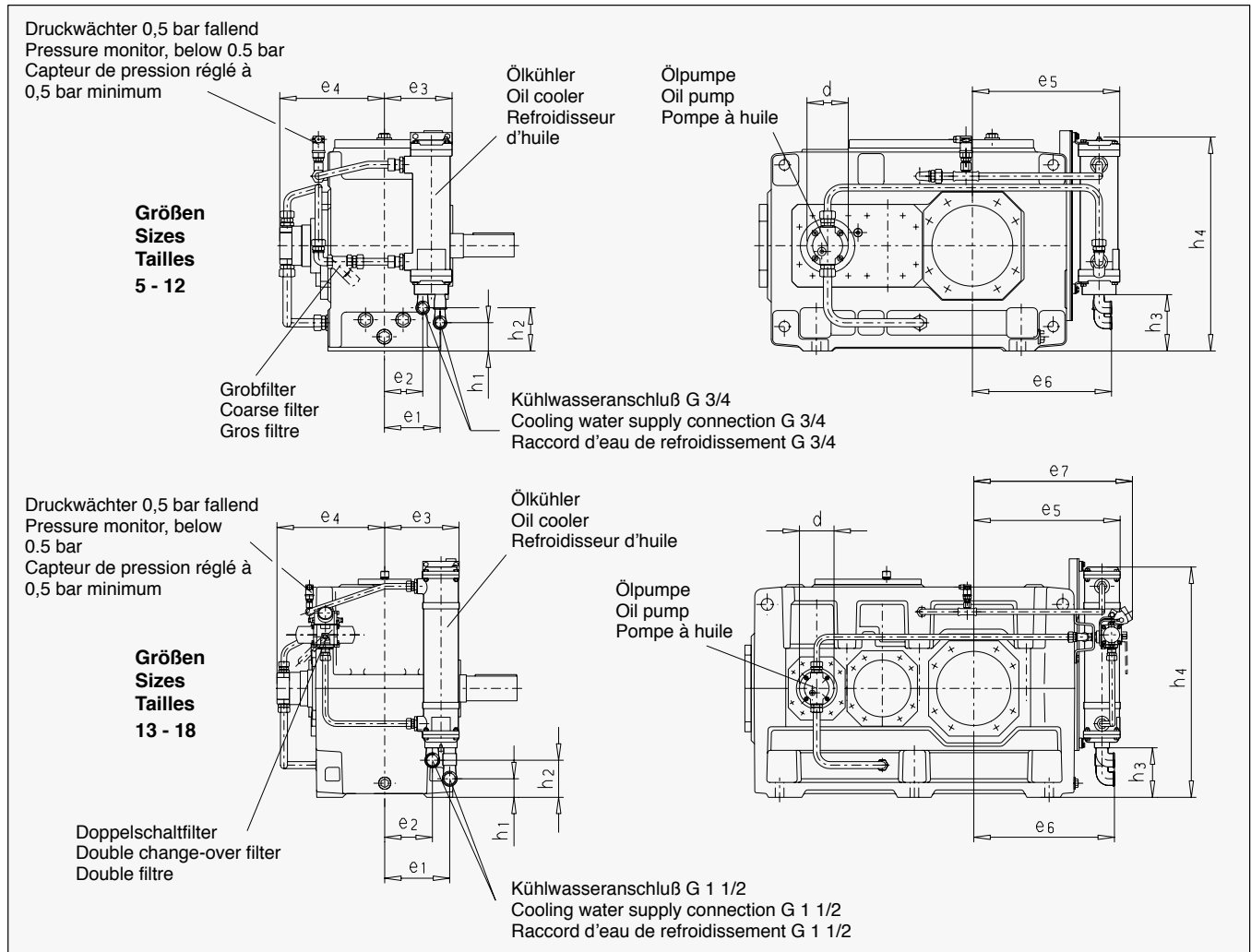
Vertikalgetriebe auf Anfrage  
Wärmegrenzleistungen auf Anfrage  
Kühler geeignet für Süß- und Seewasser

\*) For all transmission ratios  
( $n_1 = 750 - 1800 \text{ min}^{-1}$ )

If the thermal capacities  $P_{GD}$  are exceeded, oil cooler and oil pump have to be provided, possibly together with a fan.

Vertical gear units on request  
Thermal capacities on request  
Cooler suitable for fresh and sea water

\*) Pour tout rapports  
( $n_1 = 750 - 1800 \text{ min}^{-1}$ )

Lors du dépassement des capacités thermiques limites  $P_{GD}$ , prévoir un refroidisseur d'huile et une pompe à huile éventuellement couplés avec un système de refroidissement.

Réducteurs verticaux sur demande  
Capacités thermiques limites sur demande  
Refroidisseur adapté à l'eau douce et à l'eau de mer

## Zahnradgetriebe

Wasser-Ölkühler  
Horizontal  
Bauart B2.H  
Größen 5 - 12

## Gear Units

Water-oil Cooler  
Horizontal  
Type B2.H  
Sizes 5 - 12

## Réducteurs à engrenages

Refroidisseur d'huile-eau  
Horizontal  
Type B2.H  
Tailles 5 - 12

K20/020



Tabelle / Table / Tableau 14

Getriebe- größe Gear unit size Taille réducteur	Ölkühler / Oil cooler / Refroidisseur d'huile											Ölpumpe / Oil pump Pompe à huile *	
	Größe Size Taille	e <sub>1</sub>	e <sub>2</sub>	e <sub>3</sub>	e <sub>4</sub>	e <sub>5</sub>	e <sub>6</sub>	h <sub>1</sub>	h <sub>2</sub>	h <sub>3</sub>	h <sub>4</sub>	KSW Größe Size / Taille	d mm
mm													
5	01	158	112	190	340	355	323	55	95	130	550	3	140
					313							2	110
					298							1	110
6	01	158	112	190	340	400	368	55	95	130	550	3	140
					313							2	110
					298							1	110
7	01	188	142	220	370	400	368	75	115	150	570	3	140
					343							2	110
					328							1	110
8	01	188	142	220	370	460	428	75	115	150	570	3	140
					343							2	110
					328							1	110
9	01	218	172	250	399	460	418	150	190	225	645	3	140
					372							2	110
					357							1	110
10	01	218	172	250	399	500	468	150	190	225	645	3	140
					372							2	110
					357							1	110
11	01	263	217	295	440	500	463	225	265	300	720	3	140
					413							2	110
					398							1	110
12	01	263	217	295	440	580	548	225	265	300	720	3	140
					413							2	110
					398							1	110

Beim Überschreiten der Wärmegrenzleistungen  $P_{GD}$  sind Ölkühler und Ölpumpe vorzusehen, (evtl. zusammen mit Lüfterbetrieb).

If the thermal capacities  $P_{GD}$  are exceeded, oil cooler and oil pump have to be provided, possibly together with a fan.

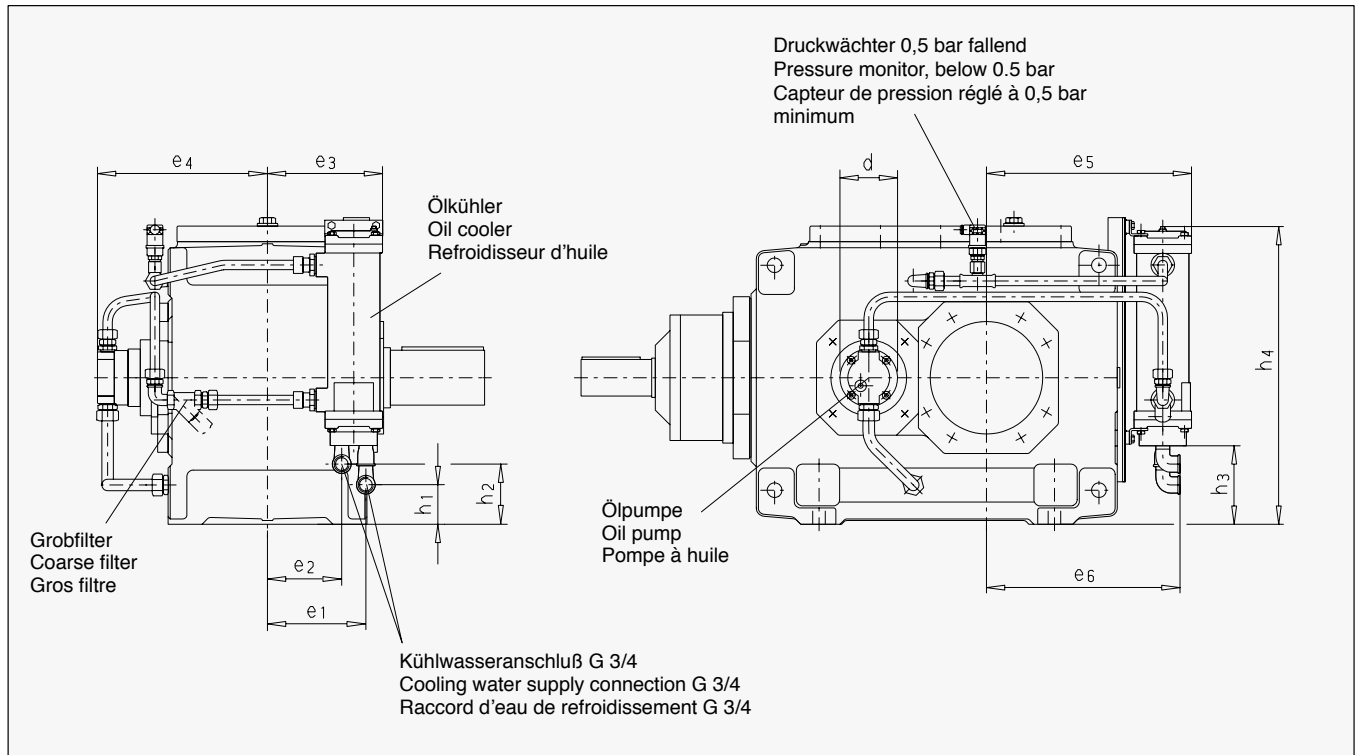
Lors du dépassement des capacités thermiques limites  $P_{GD}$ , prévoir un refroidisseur d'huile et une pompe à huile éventuellement couplés avec un système de refroidissement.

Vertikalgetriebe auf Anfrage  
Wärmegrenzleistungen auf Anfrage  
Geeignet für Süß- und Seewasser

Vertical gear units on request  
Thermal capacities on request  
Cooler suitable for fresh and sea water

Réducteurs verticaux sur demande  
Capacités thermiques limites sur demande  
Refroidisseur adapté à l'eau douce et à l'eau de mer

\*) Bei unterschiedlichen Pumpengrößen gelten die für Vertikalgetriebe festgelegten Übersetzungsanordnungen und Drehzahlen  $n_1$ , siehe Seite 140.

\*) For different pump sizes the transmission ratio assignments will apply as determined for vertical gear units and speeds  $n_1$ , see page 140.

\*) Pour les réducteurs verticaux, l'étagement des rapports de réduction et la vitesse  $n_1$  définissent les différentes tailles de pompes, voir page 140.



## Zahnradgetriebe

Wasser-Ölkühler  
Horizontal  
Bauart B2.H  
Größen 13 - 18

## Gear Units

Water-oil Cooler  
Horizontal  
Type B2.H  
Sizes 13 - 18

## Réducteurs à engrenages

Refroidisseur d'huile-eau  
Horizontal  
Type B2.H  
Tailles 13 - 18

K20/020



Tabelle / Table / Tableau 15

Getriebe- größe Gear unit size Taille réducteur	Ölkühler / Oil cooler / Refroidisseur d'huile												Ölpumpe / Oil pump Pompe à huile *	
	Größe Size Taille	e <sub>1</sub>	e <sub>2</sub>	e <sub>3</sub>	e <sub>4</sub>	e <sub>5</sub>	e <sub>6</sub>	e <sub>7</sub>	h <sub>1</sub>	h <sub>2</sub>	h <sub>3</sub>	h <sub>4</sub>	KSW Größe Size / Taille	d mm
13	03	320	250	355	487	595	573	645	75	150	200	938	3	140
					460		698						2	110
14	03	320	250	355	487	665	643	715	75	150	200	938	3	140
					460		698						2	110
15	03	375	305	410	543	675	653	725	105	180	230	968	3	140
					516		698						2	110
16	03	375	305	410	543	720	698	770	105	180	230	968	3	140
					516		698						2	110
17	03	435	365	470	605	720	693	770	145	220	270	1008	3	140
					578		698						2	110
18	03	435	365	470	605	775	753	825	145	220	270	1008	3	140
					578		698						2	110

Beim Überschreiten der Wärmegrenzleistungen  $P_{GD}$  sind Ölkühler und Ölpumpe vorzusehen, (evtl. zusammen mit Lüfterbetrieb).

If the thermal capacities  $P_{GD}$  are exceeded, oil cooler and oil pump have to be provided, possibly together with a fan.

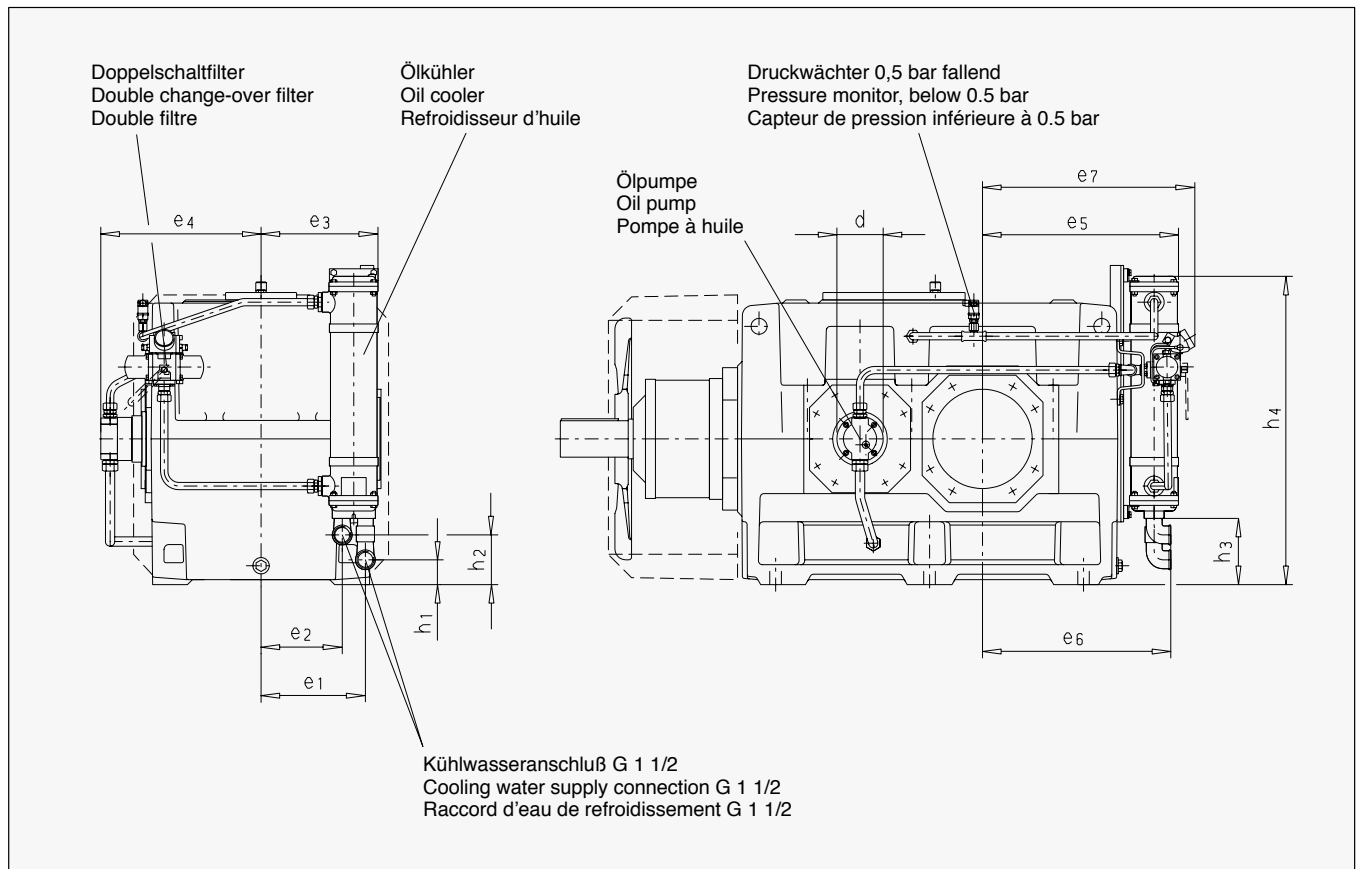
Lors du dépassement des capacités thermiques limites  $P_{GD}$ , prévoir un refroidisseur d'huile et une pompe à huile éventuellement couplés avec un système de refroidissement.

Vertikalgetriebe auf Anfrage  
Wärmegrenzleistungen auf Anfrage  
Geeignet für Süß- und Seewasser

Vertical gear units on request  
Thermal capacities on request  
Cooler suitable for fresh and sea water

Réducteurs verticaux sur demande  
Capacités thermiques limites sur demande  
Refroidisseur adapté à l'eau douce et à l'eau de mer

\*) Bei unterschiedlichen Pumpengrößen gelten die für Vertikalgetriebe festgelegten Übersetzungszuordnungen und Drehzahlen  $n_1$ , siehe Seite 140.

\*) For different pump sizes the transmission ratio assignments will apply as determined for vertical gear units and speeds  $n_1$ , see page 140.

\*) Pour les réducteurs verticaux, l'étagement des rapports de réduction et la vitesse  $n_1$  définissent les différentes tailles de pompes, voir page 140.

## Zahnradgetriebe

Luft-Ölkühler  
Horizontal  
Bauart H1SH  
Größen 5 - 11

## Gear Units

Air-oil Cooler  
Horizontal  
Type H1SH  
Sizes 5 - 11

## Réducteurs à engrenages

Refroidisseur d'huile-air  
Horizontal  
Type H1SH  
Tailles 5 - 11

K20/021



Tabelle / Table / Tableau 16

Getriebe- größe Gear unit size Taille réducteur	A	B	C	D	E	F	G	H	X <sub>min</sub>	Größe / Size / Taille			
										Luft-Ölkühler Air-oil cooler Refroidisseur d'huile-air	Pumpe / Pump / Pompe *		
											KSW	d	Übersetzung Ratio / Rapport i <sub>ges</sub>
5	655	240	250	470	282	46.5	75	438	130	03 - 3N - 1500	1	110	1.25 ... 5.6
7	695	210	250	470	335	40	80	506		04 - 1N - 1500	2	110	1.25 ... 4
					320					1	110	4.5 ... 5.6	
9	865	240	320	540	373	50	100	612		05 - 1N - 1500	2	110	1.25 ... 2.8
					373					2	110	3.15 ... 4	
11	925	240	320	540	433	38	130	712		06 - 1N - 1500	3	140	1.6 ... 2.8
					433						3	140	3.15 ... 4
					406						2	110	4.5 ... 5.6

\*) Gültig für Drehzahlen  $n_1 = 900 - 1800 \text{ min}^{-1}$   
Vertikalgetriebe auf Anfrage  
Wärmegrenzleistungen auf Anfrage

\*) Applies to speeds  $n_1 = 900 - 1800 \text{ min}^{-1}$   
Vertical gear units on request  
Thermal capacities on request

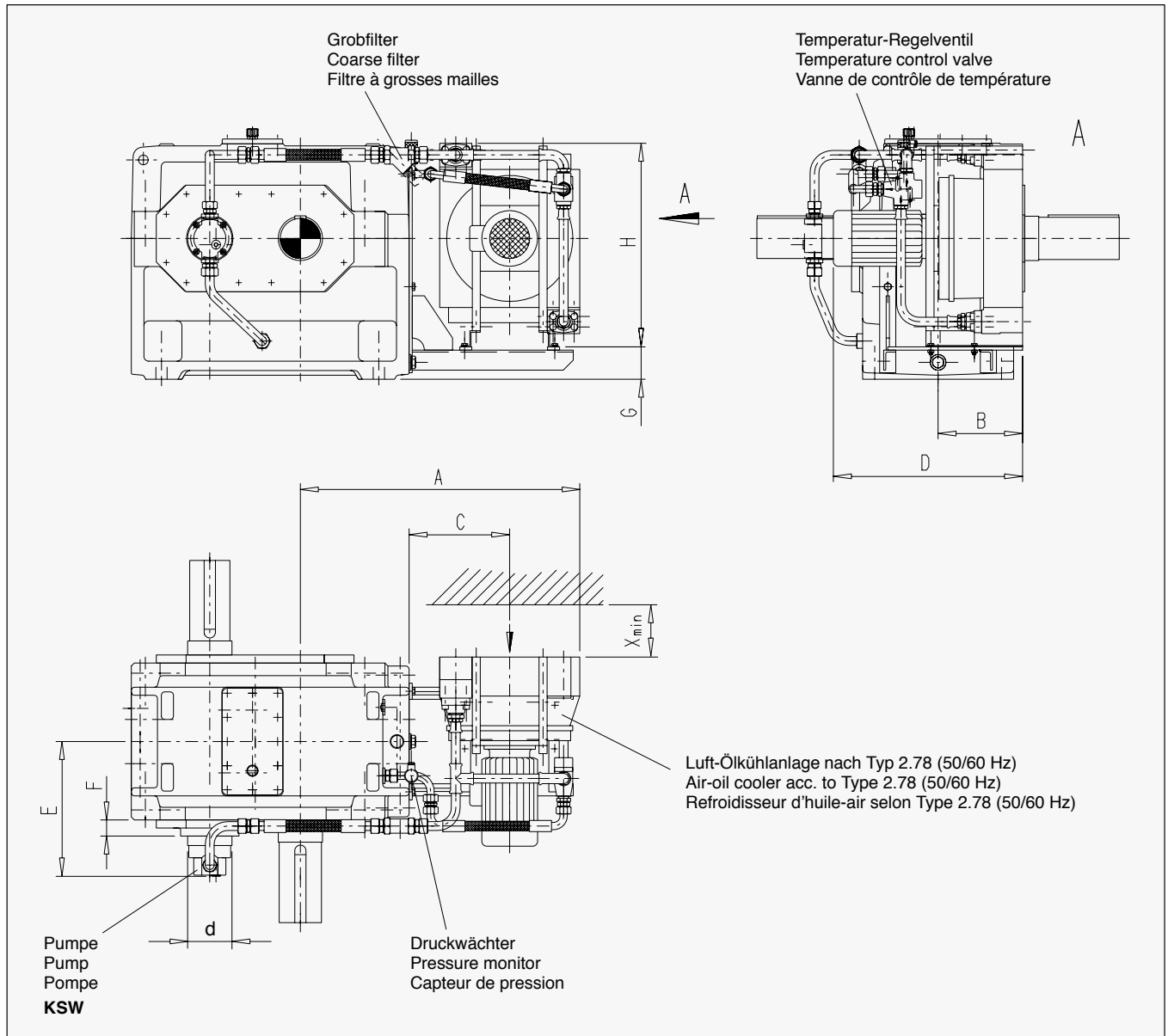
\*) Valable pour vitesses  $n_1 = 900 - 1800 \text{ min}^{-1}$   
Réducteurs verticaux sur demande  
Capacités thermiques limites sur demande

## Zahnradgetriebe

Luft-Ölkühler  
Horizontal  
Bauart H1SH  
Größen 13 - 17

## Gear Units

Air-oil Cooler  
Horizontal  
Type H1SH  
Sizes 13 - 17

## Réducteurs à engrenages

Refroidisseur d'huile-air  
Horizontal  
Type H1SH  
Tailles 13 - 17

K20/021



Tabelle / Table / Tableau 17

Getriebe- größe Gear unit size Taille réducteur	A	B	C	D	E	F	G	H	K	X <sub>min</sub>	Größe / Size / Taille			
											Luft-Ölkühler Air-oil cooler Refroidisseur d'huile-air	Pumpe / Pump / Pompe *		
												KSW	d	Übersetzung Ratio / Rapport i <sub>ges</sub>
13	1107	350	400	574	469	40	115	721	1100	130	07 - 1N - 1500	3	140	1.6 ... 2.8
					442							3	140	3.15 ... 4
												2	110	4.5 ... 5.6
15	1185	355	400	574	474	60	135	853	1190	250	08 - 1N - 1500	3	140	2 ... 2.8
					474							3	140	3.15 ... 4
					447							2	110	4.15 ... 5.6
17	1360	357	480	635	491	42	235	853	1310	350	09 - 1N - 1000	3	140	2 ... 2.8
					491							3	140	3.15 ... 4
					455							2	110	4.5 ... 5.6

\*) Gültig für Drehzahlen  $n_1 = 900 - 1800 \text{ min}^{-1}$   
Vertikalgetriebe auf Anfrage  
Wärmegrenzleistungen auf Anfrage

\*) Applies to speeds  $n_1 = 900 - 1800 \text{ min}^{-1}$   
Vertical gear units on request  
Thermal capacities on request

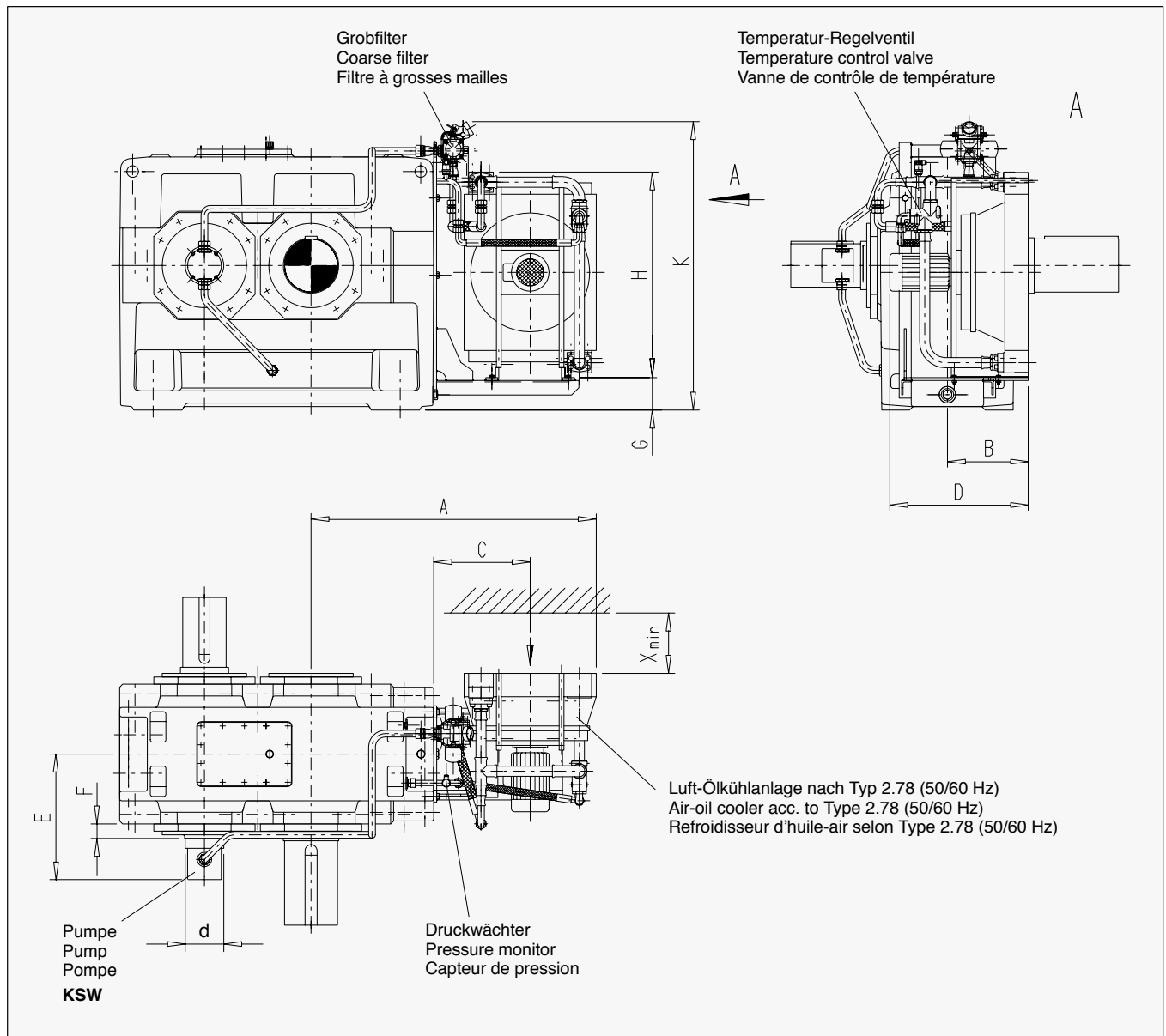
\*) Valable pour vitesses  $n_1 = 900 - 1800 \text{ min}^{-1}$   
Réducteurs verticaux sur demande  
Capacités thermiques limites sur demande

## Zahnradgetriebe

Luft-Ölkühler  
Horizontal  
Bauart H2.H  
Größen 5 - 12

## Gear Units

Air-oil Cooler  
Horizontal  
Type H2.H  
Sizes 5 - 12

## Réducteurs à engrenages

Refroidisseur d'huile-air  
Horizontal  
Type H2.H  
Tailles 5 - 12

K20/021



Tabelle / Table / Tableau 18

Getriebe- größe Gear unit size Taille réducteur	A	B	C	D	E	F	G	H	$X_{min}$	Größe / Size / Taille		
										Luft-Ölkühler Air-oil cooler Refroidisseur d'huile-air	Pumpe / Pump Pompe *	
											KSW	d
5	580	250	225	425	263	50	125	376	130	02 - 3N - 1500	1	110
6	625	250	225	525	263	50	125	376				
7	680	240	255	470	283	48	150	438				
8	740	240	255	470	283	48	150	438				
9	730	230	255	470	306	36	150	506				
10	780	230	255	470	306	36	150	506				
11	880	260	310	540	342	42	190	612				
12	965	260	310	540	342	42	190	612				

\*) Für alle Übersetzungen  
( $n_1 = 750 - 1800 \text{ min}^{-1}$ )

Vertikalgetriebe auf Anfrage  
Wärmegrenzleistungen auf Anfrage

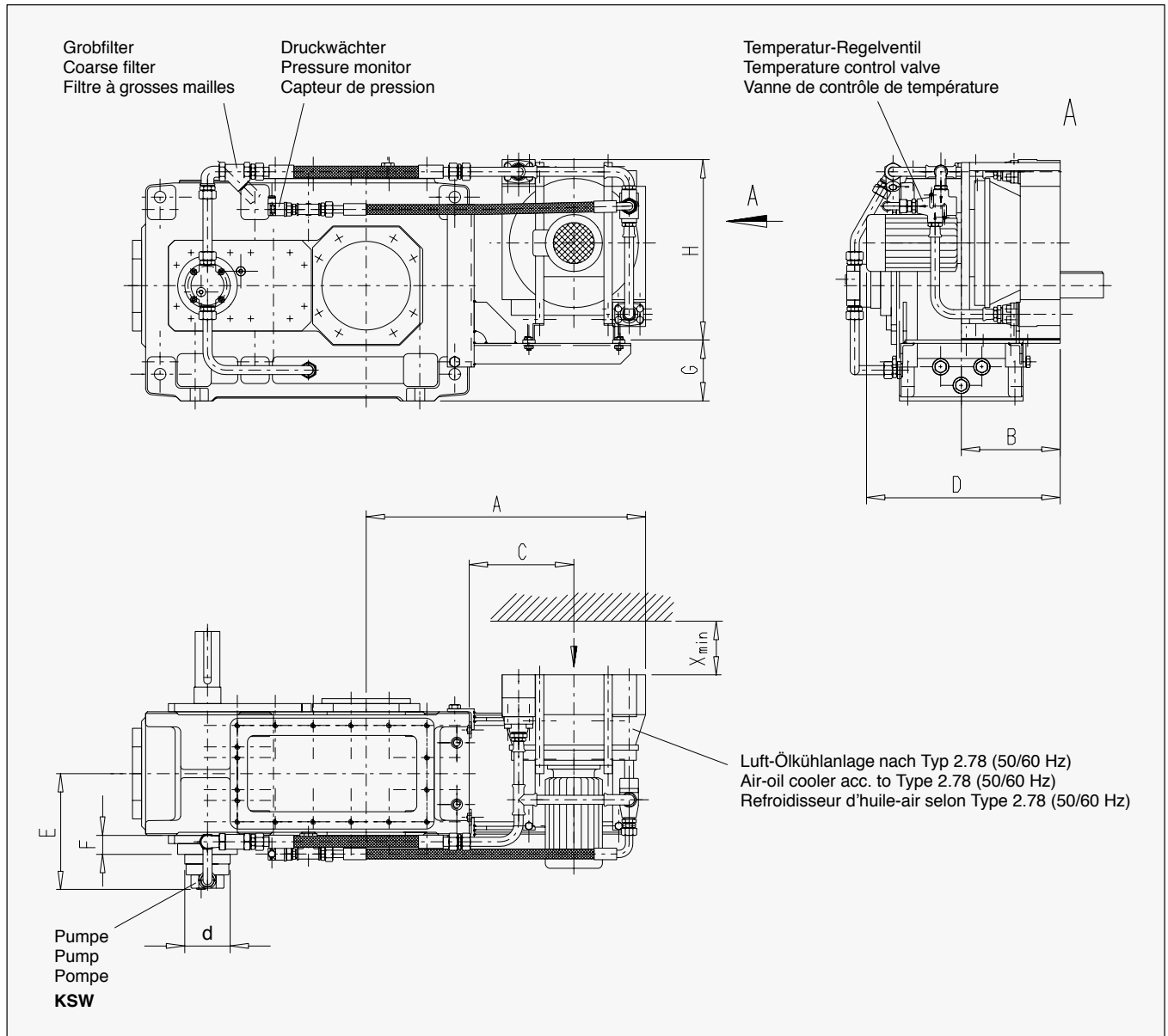
\*) For all transmission ratios  
( $n_1 = 750 - 1800 \text{ min}^{-1}$ )

Vertical gear units on request  
Thermal capacities on request

\*) Pour tous rapports  
( $n_1 = 750 - 1800 \text{ min}^{-1}$ )

Réducteurs verticaux sur demande  
Capacités thermiques limites sur demande

## Zahnradgetriebe

Luft-Ölkühler  
Horizontal  
Bauart H2.H  
Größen 13 - 18

## Gear Units

Air-oil Cooler  
Horizontal  
Type H2.H  
Sizes 13 - 18

## Réducteurs à engrenages

Refroidisseur d'huile-air  
Horizontal  
Type H2.H  
Tailles 13 - 18

K20/021



Tabelle / Table / Tableau 19

Getriebe- größe Gear unit size Taille réducteur	A	B	C	D	E	F	G	H	K	X <sub>min</sub>	Größe / Size / Taille			
											Luft-Ölkühler Air-oil cooler Refroidisseur d'huile-air		Pumpe / Pump Pompe *	
													KSW	d
13	1000	270	365	540	410	37	95	712	990	130	06 - 3N - 1500		2	110
14	1070	270	365	540	410	37	95	712	990	130	06 - 3N - 1500			
15	1175	290	410	574	445	35	150	721	1090	130	07 - 3N - 1500			
16	1220	290	410	574	445	35	150	721	1090	130	07 - 3N - 1500			
17	1215	290	410	574	475	35	170	853	1195	250	08 - 3N - 1500			
18	1275	290	410	574	475	35	170	853	1195	250	08 - 3N - 1500			

\*) Für alle Übersetzungen  
( $n_1 = 750 - 1800 \text{ min}^{-1}$ )

Vertikalgetriebe auf Anfrage  
Wärmegrenzleistungen auf Anfrage

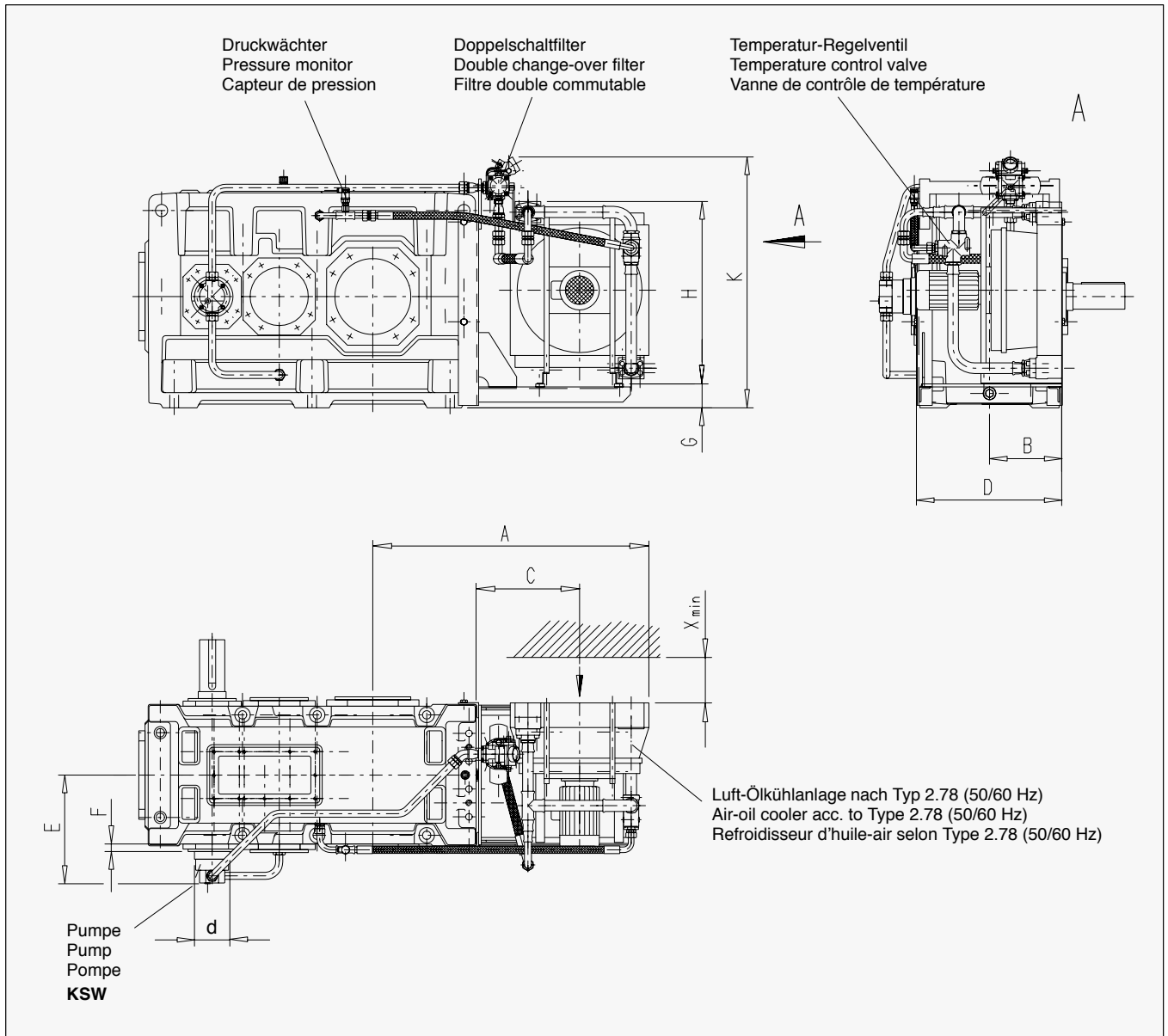
\*) For all transmission ratios  
( $n_1 = 750 - 1800 \text{ min}^{-1}$ )

Vertical gear units on request  
Thermal capacities on request

\*) Pour tous rapports  
( $n_1 = 750 - 1800 \text{ min}^{-1}$ )

Réducteurs verticaux sur demande  
Capacités thermiques limites sur demande

## Zahnradgetriebe

Luft-Ölkühler  
Horizontal  
Bauart B2.H  
Größen 5 - 12

## Gear Units

Air-oil Cooler  
Horizontal  
Type B2.H  
Sizes 5 - 12

## Réducteurs à engrenages

Refroidisseur d'huile-air  
Horizontal  
Type B2.H  
Tailles 5 - 12

K20/021



Tabelle / Table / Tableau 20

Getriebe- größe Gear unit size Taille réducteur	A	B	C	D	E	F	G	H	X <sub>min</sub>	Größe / Size / Taille		
										Luft-Ölkühler Air-oil cooler Refroidisseur d'huile-air	Pumpe / Pump Pompe *	
											KSW	d
5	634	190	255	470	340	53	80	438	130	03 - 3N - 1500	3	140
					313						2	110
					298						1	110
6	679	190	255	470	340	53	80	438	130	03 - 3N - 1500	3	140
					313						2	110
					298						1	110
7	679	220	255	470	370	53	80	506	130	04 - 3N - 1500	3	140
					343						2	110
					328						1	110
8	739	220	255	470	370	53	80	506	130	04 - 3N - 1500	3	140
					343						2	110
					328						1	110
9	887	220	310	540	399	52	80	612	130	05 - 3N - 1500	3	140
					372						2	110
					357						1	110
10	937	220	310	540	399	52	80	612	130	05 - 3N - 1500	3	140
					372						2	110
					357						1	110
11	882	220	310	540	440	48	80	712	130	06 - 3N - 1500	3	140
					413						2	110
					398						1	110
12	967	220	310	540	440	48	80	712	130	06 - 3N - 1500	3	140
					413						2	110
					398						1	110

Vertikalgetriebe auf Anfrage  
Wärmegrenzleistungen auf Anfrage

\*) Bei unterschiedlichen Pumpengrößen gelten die für Vertikalgetriebe festgelegten Übersetzungszuordnungen und Drehzahlen  $n_1$ , siehe Seite 140.

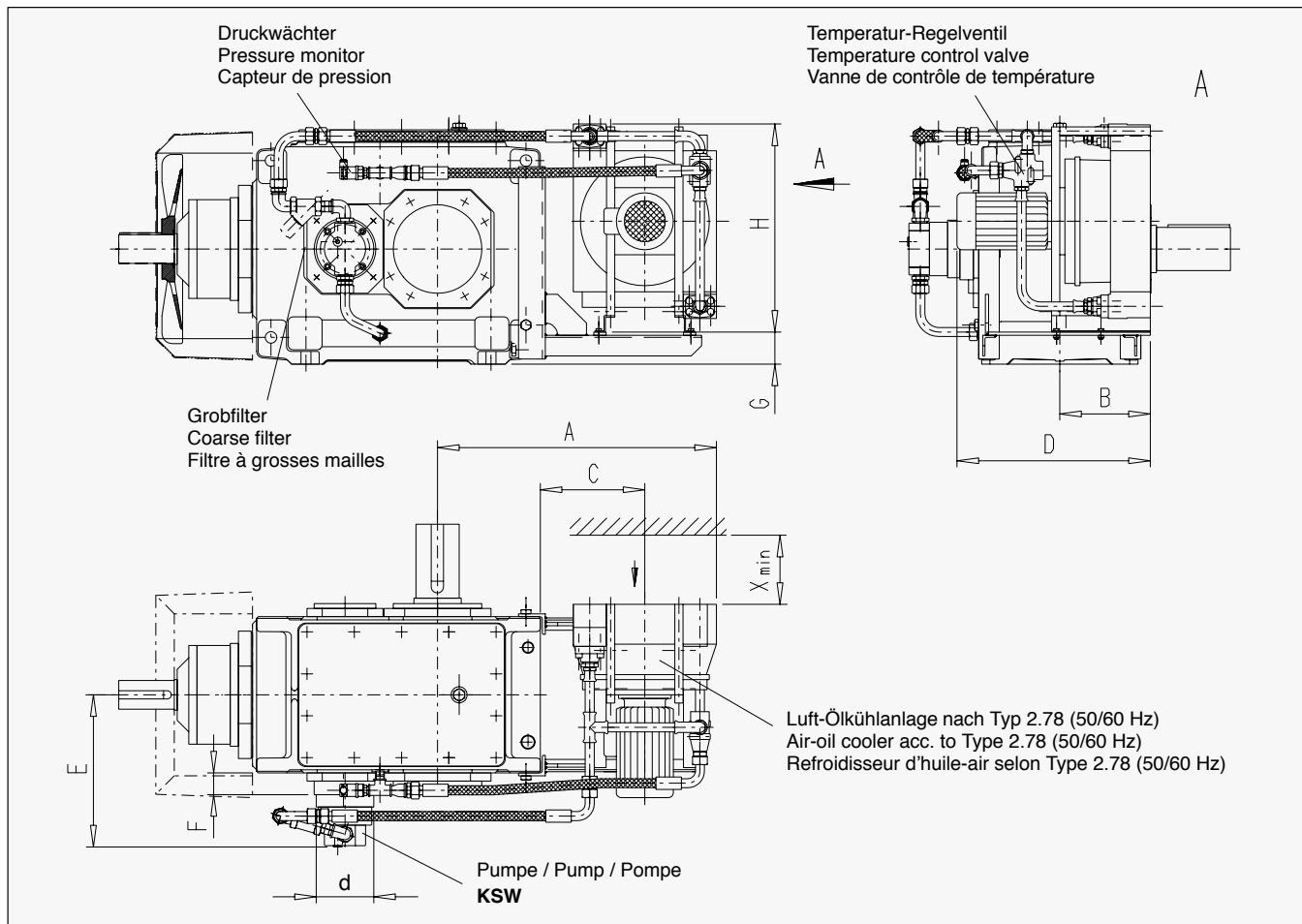
Vertical gear units on request  
Thermal capacities on request

\*) For different pump sizes the transmission ratio assignments will apply as determined for vertical gear units and speeds  $n_1$ , see page 140.

Réducteurs verticaux sur demande  
Capacités thermiques limites sur demande

\*) Pour les réducteurs verticaux, l'étagement des rapports de réduction et la vitesse  $n_1$  définissent les différentes tailles de pompes, voir page 140.

## Zahnradgetriebe

Luft-Ölkühler  
Horizontal  
Bauart B2.H  
Größen 13 - 18

## Gear Units

Air-oil Cooler  
Horizontal  
Type B2.H  
Sizes 13 - 18

## Réducteurs à engrenages

Refroidisseur d'huile-air  
Horizontal  
Type B2.H  
Tailles 13 - 18

K20/021



Tabelle / Table / Tableau 21

Getriebe- größe Gear unit size Taille réducteur	A	B	C	D	E	F	G	H	K	X <sub>min</sub>	Größe / Size / Taille		
											Luft-Ölkühler Air-oil cooler Refroidisseur d'huile-air	Pumpe / Pump Pompe *	
												KSW	d
13	1092	230	410	574	487 460	35	95	721	995	130	07 - 3N - 1500	3	140
												2	110
14	1162	230	410	574	487 460	35	95	721	995	130	07 - 3N - 1500	3	140
												2	110
15	1172	175	410	574	543 516	36	95	853	1095	250	08 - 3N - 1500	3	140
												2	110
16	1217	175	410	574	543 516	36	95	853	1095	250	08 - 3N - 1500	3	140
												2	110
17	1337	150	480	635	605 578	40	113.5	853	1200	350	09 - 3N - 1000	3	140
												2	110
18	1397	150	480	635	605 578	40	113.5	853	1200	350	09 - 3N - 1000	3	140
												2	110

Vertikalgetriebe auf Anfrage  
Wärmegrenzleistungen auf Anfrage

\*) Bei unterschiedlichen Pumpengrößen gelten die für Vertikalgetriebe festgelegten Übersetzungszuordnungen und Drehzahlen  $n_1$ , siehe Seite 140.

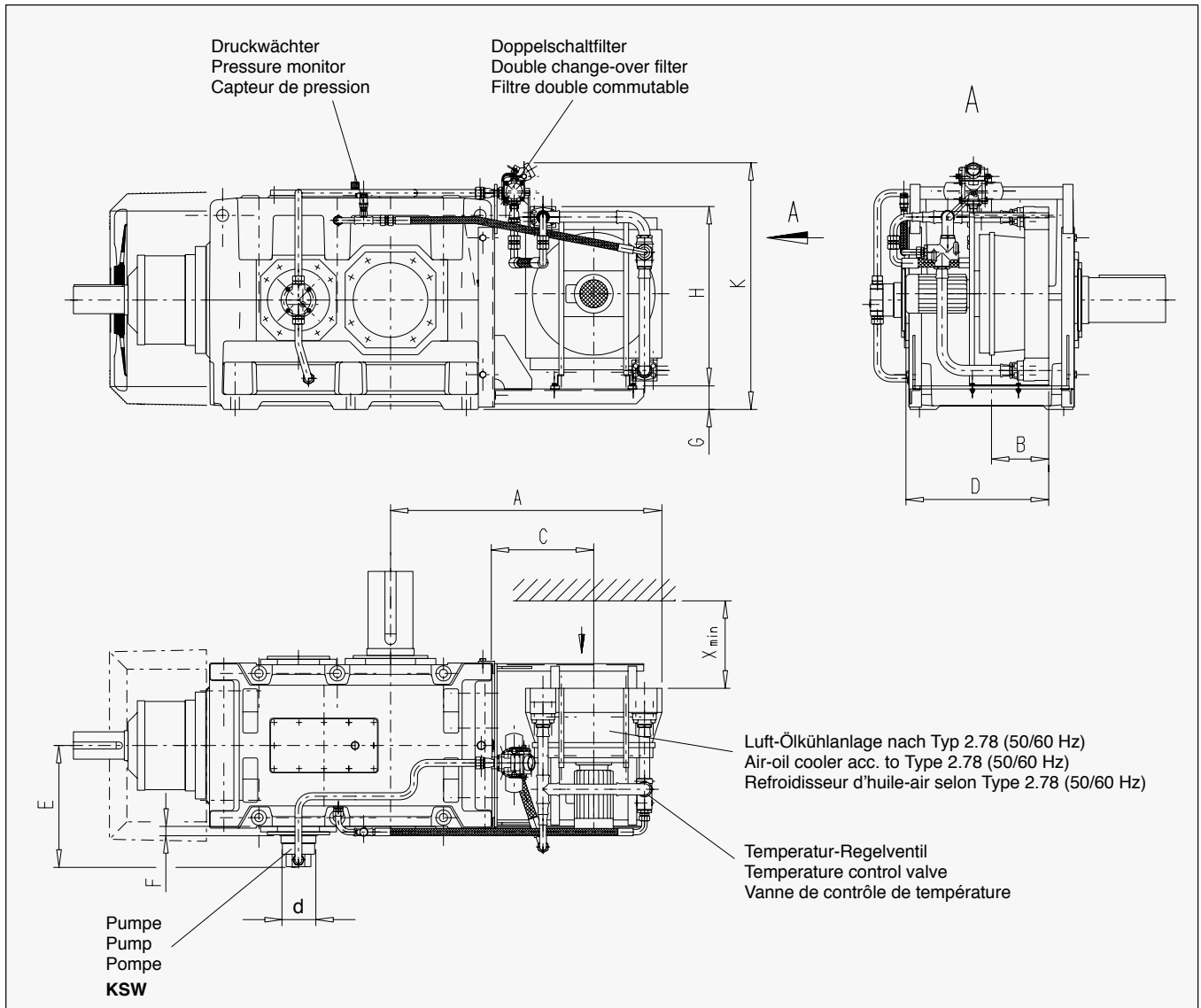
Vertical gear units on request  
Thermal capacities on request

\*) For different pump sizes the transmission ratio assignments will apply as determined for vertical gear units and speeds  $n_1$ , see page 140.

Réducteurs verticaux sur demande  
Capacités thermiques limites sur demande

\*) Pour les réducteurs verticaux, l'étagement des rapports de réduction et la vitesse  $n_1$  définissent les différentes tailles de pompes, voir page 140.

# Zahnradgetriebe

mit Heizstäben

# Gear Units

With Heating Elements

# Réducteurs à engrenages

avec cannes de préchauffage

Bauarten H2, H3, H4, B2, B3, B4  
Größen 4 - 18

Types H2, H3, H4, B2, B3, B4  
Sizes 4 - 18

Types H2, H3, H4, B2, B3, B4  
Tailles 4 - 18

K20/022

Getriebegröße Gear unit size Taille réducteur	4 - 12	13 - 18
Horizontale Einbaulage Horizontal mounting position Position de montage horizontale		
Aufsteckausführung Shaft-mounted design Exécution flottante		
Vertikale Einbaulage Vertical mounting position Position de montage vertical		

Labyrinthdichtung als Wellenabdichtung nicht möglich

Labyrinth seal not possible as shaft seal

Étanchéité à labyrinthe impossible comme étanchéité d'arbre

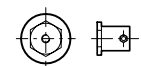

- 1) Einschraubheizkörper, Technische Daten und Hinweise: Schutzart IP 65, 230 V, 50 Hz, Leistung je nach Auslegung (Rückfrage erforderlich)

- 1) Screwed heating element; Technical data and notes: type of protection IP 65, 230V, 50 Hz, power rating dependent on design. (Please refer to us)

- 1) Corps de chauffe à visser, données techniques et indications: type de protection IP 65, 230 V, 50 Hz puissance selon conception (consultation nécessaire)

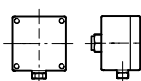

- 2) Temperaturwächter ATH-SW22 Technische Daten und Hinweise: Schutzart IP 65, 2 Umschaltkontakte (einstellbar), max Schaltleistung: 2 A/ 230 V AC/460 VA  $\cos \varphi = 0,6$  (Wechselspannung), 0,25 A/ 230 V DC/58 W (Gleichspannung)

- 2) Temperature monitor ATH-SW22; Technical data and notes: type of protection IP 65, 2 change-over contacts (adjustable), max. switching capacity 2 A/ 230 V AC/460 VA  $\cos \varphi = 0,6$  (alternating current), 0,25 A/ 230 V DC/58 W (direct current)

- 2) Contrôleur de température ATH-SW22, données techniques et indications: type de protection IP 65, 2 contacts de commutation (réglables), puissance de commutation max: 2 A/ 230 V AC/460 VA  $\cos \varphi = 0,6$  (courant alternatif) 0,25 A/ 230 V DC/58 W (courant continu)

- 3) Entfällt bei Größen 4, 6, 8, 10, 12, 14, 16, 18

- 3) Not applicable for sizes 4, 6, 8, 10, 12, 14, 16, 18

- 3) Sauf pour tailles 4, 6, 8, 10, 12, 14, 16, 18

Der Einsatz von Heizstäben ist erforderlich, wenn die Grenztemperatur zur Schmierung unterschritten wird.

The use of heating elements will be necessary if the temperature limit for lubrication is undershot.

L'utilisation de cannes de préchauffage est nécessaire lorsque la température limite de lubrification par barbotage est dépassée.

Je nach Ausführung können Einschraubheizkörper und Temperaturwächter spiegelbildlich angeordnet sein.

Dependent on the design, screwed heating elements and temperature monitors may be arranged mirror-inverted.

Des corps de chauffe à visser et des contrôleurs de température peuvent être disposés de façon symétrique selon le modèle.

Abmessungen auf Anfrage

Dimensions on request

Dimensions sur demande



## Zahnradgetriebe

mit Öltemperaturmessung

Bauarten H2, H3, H4, B2, B3, B4  
Größen 4 - 18

## Gear Units

With Thermometer for  
Oil Temperature

Types H2, H3, H4, B2, B3, B4  
Sizes 4 - 18

## Réducteurs à engrenages

avec mesure de la température  
de l'huile

Types H2, H3, H4, B2, B3, B4  
Tailles 4 - 18

K20/023

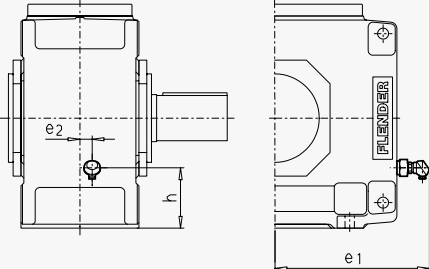
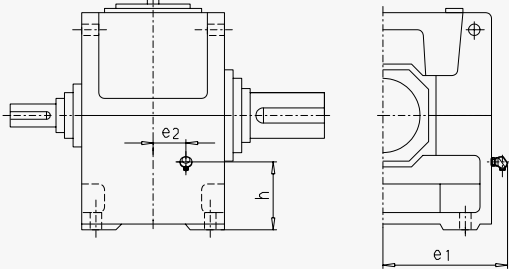
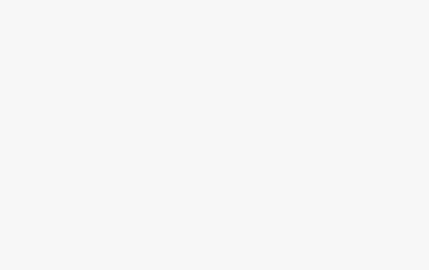
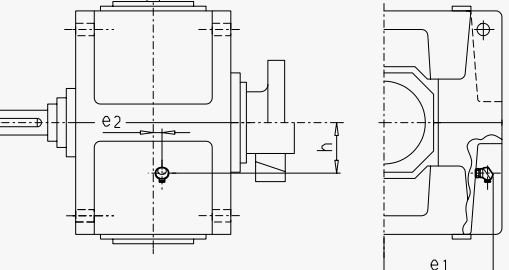
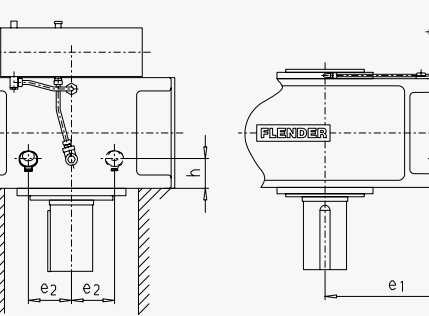
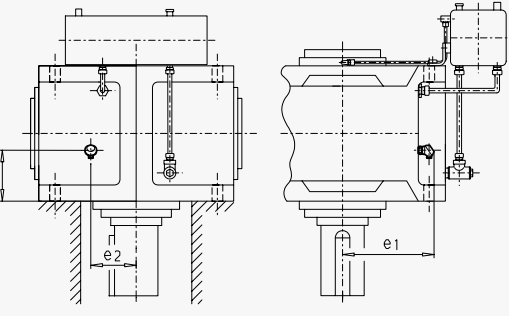
Getriebegröße Gear unit size Taille réducteur	4 - 12	13 - 18
Horizontale Einbaulage Horizontal mounting position Position de montage horizontal		
Aufsteck- ausführung Shaft-mounted design Exécution flottante		
Vertikale Einbaulage Vertical mounting position Position de montage vertical		

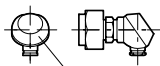

PG 9

### Widerstandsthermometer PT 100

#### Technische Daten und Hinweise:

Schutzart Anschlußkopf: IP 54,  
Zweileiterschaltung  
Anschluß in Drei- bzw. Vierleiterschaltung kundenseitig ebenfalls möglich.  
Anschluß an ein Auswertegerät erforderlich!

Je nach Ausführung kann das Widerstandsthermometer spiegelbildlich angeordnet sein.  
Labyrinthdichtung als Wellenabdichtung nicht möglich.

Abmessungen auf Anfrage

### Resistance thermometer PT 100

#### Technical data and notes:

Type of protection for terminal head: IP 54, two-wire connection.  
Three- and four-wire connection at the customer's is also possible.  
Connection to an evaluation instrument is necessary!

Dependent on the design, the resistance thermometer may be arranged mirror-inverted.  
Labyrinth seal not possible as shaft seal.

Dimensions on request

### Thermomètre à résistance PT 100

#### Données techniques et indications:

Type de protection tête de raccordement: IP 54, branchement en double voie.  
Raccord en branchement trois ou quatre fils également possible côté client.  
Raccord nécessaire à un dispositif d'exploitation des données!

Le thermomètre à résistance peut être disposé de façon symétrique selon le modèle.

Étanchéité à labyrinthe impossible comme étanchéité d'arbre.

Dimensions sur demande

# Zahnradgetriebe

Wellenabdichtungen

# Gear Units

Shaft Seals

# Réducteurs à engrenages

Etanchéités des arbres

Bauarten H1 - H4, B2 - B4  
Größen 3 - 26

Types H1 - H4, B2 - B4  
Sizes 3 - 26

Types H1 - H4, B2 - B4  
Tailles 3 - 26

K20/005

Bauart Type	Größe Size Taille	Radialwellendichtring Radial shaft seal Bague d'étanchéité radiale		Labyrinthdichtung <sup>2)</sup> Labyrinth seal Etanchéité à labyrinthe		Taconite-Dichtung <sup>1)</sup> Taconite seal Etanchéité Taconite	
		d <sub>1</sub>	d <sub>2</sub>	d <sub>1</sub> <sup>3)</sup>	d <sub>2</sub>	d <sub>1</sub> <sup>3)</sup>	d <sub>2</sub>
<b>H1SH</b>	<b>3 - 17</b>	<b>H</b>	<b>H</b>	<b>H</b>	<b>H</b>	<b>H</b>	<b>H</b>
<b>H2..</b>	<b>4 - 18</b>	<b>H / V</b>	<b>H / V</b>	<b>H</b>	<b>-</b>	<b>H / V</b>	<b>H / V</b>
<b>H3..</b>	<b>5 - 18</b>	<b>H / V</b>	<b>H / V</b>	<b>-</b>	<b>-</b>	<b>H<sup>2)</sup> / V</b>	<b>H / V</b>
<b>H4..</b>	<b>7 - 18</b>	<b>H / V</b>	<b>H / V</b>	<b>-</b>	<b>-</b>	<b>H / V</b>	<b>H / V</b>
<b>B2..</b>	<b>4 - 18</b>	<b>H / V</b>	<b>H / V</b>	<b>-</b>	<b>-</b>	<b>H / V</b>	<b>H / V</b>
<b>B3..</b>	<b>4 - 18</b>	<b>H / V</b>	<b>H / V</b>	<b>-</b>	<b>-</b>	<b>H / V</b>	<b>H / V</b>
<b>B4..</b>	<b>5 - 18</b>	<b>H / V</b>	<b>H / V</b>	<b>-</b>	<b>-</b>	<b>H / V</b>	<b>H / V</b>
	<b>19 - 26</b>	Auf Anfrage / On request / Sur demande					

H = Horizontal  
V = Vertikal

H = Horizontal  
V = Vertical

H = Horizontal  
V = Vertical

1) Mögliche Ausführungen und Einschränkungen siehe nachfolgende Seiten

1) For possible designs and restrictions, see the following pages.

1) Exécutions possibles et limitations voir pages suivantes

2) nicht in Kombination mit Lüfter

2) Not in combination with a fan

2) Pas dans l'exécution avec ventilateur

3) nicht in Kombination mit Motorlaterne

3) Not in combination with motor bell housing

3) Pas dans l'exécution avec lanterne moteur

i <sub>N</sub>	Getriebegrößen / Gear unit sizes / Tailles réducteurs																							
	3	4	5	6	7	8	9	10	11	12	13	14	15	16	17	18	19	20	21	22	23	24	25	26
	Eingangsdrehzahlen / Input speeds / Vitesses d'entrée n <sub>1</sub> in / en min <sup>-1</sup>																							
1.25	x		x		x		x																	
1.4	x		x		x		x																	
1.6	740		515		425		370		305		260													
1.8	810		570		460		395		325		285													
2	860		610		490		420		350		305		255											
2.24	920		660		550		455		375		330		275											
2.5	1020		710		595		495		405		355		295											
2.8	1100		775		635		530		445		390		320		290									
3.15	1190		850		690		600		480		430		350		315									
3.55	1300		935		755		650		530		470		380		345									
4	1430		1025		835		720		580		515		420		380									
4.5	1575		1145		905		770		640		575		475		425									
5	1730		1205		990		850		730		605		525		455									
5.6	1910		1340		1095		955		765		670		580		505									
6.3		x	x		x		515		x		370		305		260									
7.1		x	810		660		570		460		395		325	305	385	260								
8		1020	860	x	705	x	610	x	490	x	420	370	350	325	305	385								
9		1080	920	x	760	660	660	x	550	x	455	395	375	350	330	305								
10		1190	1020	860	820	705	710	610	595	x	495	420	405	375	355	330								
11.2		1280	1100	920	885	760	775	660	635	550	530	455	445	405	390	355								
12.5		1435	1190	1020	955	820	850	710	690	595	600	495	480	445	430	390								
14		1560	1300	1100	1090	885	935	775	755	635	650	530	530	480	470	430								
16		1715	1430	1190	1200	955	1025	850	835	690	720	600	580	530	515	470								
18		1890	1575	1300	1320	1090	1145	935	905	755	770	650	640	580	575	515								
20			1730	1430	1450	1200	1205	1025	990	835	850	720	730	640	605	575								
22.4			1910	1575	1530	1320	1340	1145	1095	905	x	770	x	730	x	605								
25				1075	1730	885	1450	740	1205	x	990	x	850	x	x	x	x							
28				1170	1910	940	1530	810	1340	x	1095	x	x	x	x	x	x							

x = Labyrinth nicht möglich

x = Labyrinth seals are not possible

x = Joints labyrinthes non possibles

Bei Unterschreitung der Mindest-Eingangsdrehzahl n<sub>1</sub> sind Radialwellendichtungen vorzusehen.

If the minimum input speed n<sub>1</sub> is undershot, radial shaft seals are to be provided.

Si la vitesse n<sub>1</sub> minimum n'est pas atteinte, utiliser les bagues d'étanchéité radiales.

## Zahnradgetriebe

Wellenabdichtungen

## Gear Units

Shaft Seals

## Réducteurs à engrenages

Etanchéités des arbres

Radialwellendichtringe

Labyrinthdichtungen

Radial Shaft Seals

Labyrinth Seals

Bague d'étanchéité radiale

Etanchéités par labyrinthes

K20/005

**Radialwellendichtringe**  
**Radial shaft seals**  
**Bague d'étanchéité radiale**

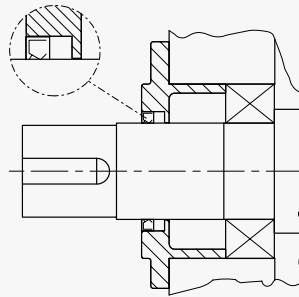

Abdichtungen durch Radialwellendichtringe sind für niedrige bis mittlere Betriebsdrehzahlen geeignet.

### Weitere Merkmale sind:

- Verschleißende Dichtung, jedoch wartungsfreundlich,
- Lokale Wärmeentwicklung an Dichtlippe, deshalb ausreichend Schmierung (Kühlung) erforderlich,
- Handelsübliches Produkt,
- Bei Flanschwellenausführung sind im Reparaturfall geteilte Wellendichtringe einzusetzen (Rücksprache erforderlich),
- Ausführung mit niedrigem Ölstand auf Anfrage.

Radialwellendichtringe können bei allen Bauarten und Größen eingesetzt werden.

Radial shaft seals are suitable for low to average operating speeds.

### Other features are:

- Wearing seal, however, easy to maintain;
- Local heat development on sealing lip; therefore, adequate lubrication (cooling) required;
- Commercial product;
- Split shaft seals are to be used in case of repair of flanged shafts (please refer to us);
- Design with low oil level on request.

Radial shaft seals can be used for all types and sizes.

Les étanchéités avec bague d'étanchéité radiale sont appropriées pour des vitesses de fonctionnement faibles et moyennes.

### Les autres caractéristiques sont:

- Pièces d'usure facile à remplacer,
- échauffement local au niveau de la lèvre nécessitant une lubrification adéquate (refroidissement),
- Produit de négoce,
- Pour les arbres avec flasques brides, il est nécessaire en cas de réparation, d'utiliser un joint coupé (nous contacter),
- Exécution avec niveau d'huile abaissé sur demande.

Les joints d'étanchéité radiaux peuvent être utilisés pour tous les types et dans toutes les tailles

**Labyrinthdichtungen**  
**Labyrinth seals**  
**Etanchéité à labyrinthes**

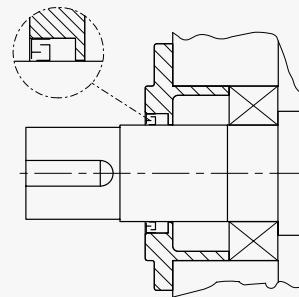

Die Labyrinthdichtungen sind für höhere Betriebsdrehzahlen besonders geeignet.

### Weitere Vorzüge sind:

- Berührungslos und somit verschleißfrei,
- Keine lokale Wärmeentwicklung, somit wartungsfrei,
- Geringer Einbauraum.

Bei der Auswahl der Labyrinthdichtungen sind folgende Kriterien zu berücksichtigen:

- Nur bei stationären Antrieben einsetzen (z.B. keine Fahrwerke),
- Nur bei Tauchschmierung, (Druckschmierung auf Anfrage),
- Extrem staubige oder durch Schmutzwasser gefährdete Aufstellungsorte meiden,
- Wellenebenen müssen waagrecht sein,
- Erforderliche Mindest-Eingangsdrehzahl  $n_1$  für Stirnradgetriebe siehe Tabelle 2,
- Bei längerer Betriebsdauer mit minimalen Drehzahlen (z.B. Kriechbetrieb bei Papiermaschinen) sind besondere Maßnahmen (Öltaubleche) erforderlich.

Labyrinth seals are specially suitable for higher operating speeds.

### Further advantages are:

- Non-contacting and thus, wear-resistant;
- No local heat development and thus, maintenance-free;
- Small space required for fitting.

For the selection of labyrinth seals the following criteria are to be considered:

- Applicable in stationary drives only (e.g. not in travelling gears);
- Only in case of dip lubrication (forced lubrication on request);
- Avoid extremely dusty environments or sites endangered by muddy water;
- Shaft levels must be horizontal;
- For min. required input speed  $n_1$  for helical gear units, see table 2;
- In case of longer operating periods at minimum speeds (e.g. creep speed in case of paper machines) special measures (oil retaining plates are required).

Les étanchéités par labyrinthe sont appropriées aux vitesses de fonctionnement élevées.

### Ils présentent en plus les avantages suivants:

- Pas de contacts, donc résistants à l'usure,
- Pas d'échauffement local donc pas d'entretien,
- Encombrement réduit.

Pour la détermination des étanchéités par labyrinthe, il y a lieu d'observer les critères suivants:

- Application exclusivement sur des entraînements stationnaires (pas de translation),
- Seulement avec lubrification par barbotage (lubrification sous pression sur demande),
- Éviter les ambiances extrêmement poussiéreuses ou les projections d'eau sales,
- Les arbres doivent être horizontaux,
- Vitesse minimum d'entrée  $n_1$  selon tableau 2 pour les réducteurs hélicoïdaux,
- En cas de fonctionnement prolongé à basse vitesse (par exemple, vitesse de virage pour les machines à papier), il est nécessaire d'avoir des dispositions spéciales (tôle de retenue d'huile).

# Zahnradgetriebe

Wellenabdichtungen

Taconite-Dichtungen

# Gear Units

Shaft Seals

Taconite Seals

# Réducteurs à engrenages

Étanchéités des arbres

Étanchéité Taconite

K20/005

**Taconite-Dichtungen**  
**Taconite seals**  
**Étanchéité Taconite**

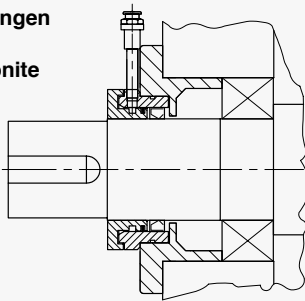

Fettgefüllte, nachschmierbare Labyrinth-Dichtungskombinationen. Mit dieser Dichtung erlangt das Getriebe in staubiger Umgebung ein hohes Maß an Betriebssicherheit. Die Dichtung ist eine Kombination von drei Dichtungselementen, die das Getriebe vor dem Eindringen staubariger Partikel schützen.

Grease-filled, refillable labyrinth seal combinations. With this seal a high degree of operational reliability is achieved for the gear unit in dusty environments. This seal is a combination of three sealing elements which protect the gear unit from ingress of dust-like particles.

Combinaison de joint à lèvres et labyrinthe avec remplissage de graisse renouvelable. Avec cette étanchéité, le réducteur se trouvant en ambiance poussiéreuse, obtient un haut niveau de sécurité de fonctionnement. Cette étanchéité est la combinaison de trois éléments qui protègent le réducteur contre l'entrée de particules de poussière.

Taconite Dichtung Seal Etanchéité	Welle Shaft Arbre	Hinweis Note Indication
<b>E</b>	Antriebswelle Input shaft Arbre d'entrée	Abmessungen für H3 und H4 beachten Take into account dimensions for H3 and H4 Respecter les cotes pour H3 et H4
<b>F</b>	Vollwelle Solid shaft Arbre plein	
	Abtriebswelle d <sub>2</sub> verstärkt Reinforced output shaft d <sub>2</sub> Arbre de sortie renforcée d <sub>2</sub>	
	Flanschwellengetriebe d <sub>2</sub> With flanged shaft d <sub>2</sub> Pour réducteur à bride d <sub>2</sub>	erst ab Größe 8 / from size 8 on / seulement à partir de la taille 8
<b>F - F</b>	Hohlwelle mit Paßfedernut Hollow shaft with keyway Arbre creux avec rainure de clavette	beidseitige Taconite-Dichtung Schutzhaube als Berührungsschutz
	Hohlwelle für Schrumpfscheibe Hollow shaft for shrink disk Arbre creux pour frette de serrage	Taconite seals on both sides Guard as protection against accidental contact
	Hohlwelle mit Zahnablenkprofil nach DIN 5480 Hollow shaft with involute splines acc. to DIN 5480 Arbre creux avec profil de moyeu denté selon DIN 5480	Etanchéité Taconite des deux cotés Capot de protection contre les contacts involontaires
<b>F - H</b>	Hohlwelle mit Paßfedernut Hollow shaft with keyway Arbre creux avec rainure de clavette	Taconite-Dichtung an der Arbeitsmaschinenwelle gegenüberliegende Seite mit staubdichter Schutzhaube Taconite seal on driven machine shaft Dustproof guard on opposite side
	Hohlwelle mit Zahnablenkprofil nach DIN 5480 Hollow shaft with involute splines acc. to DIN 5480 Arbre creux avec profil de moyeu denté selon DIN 5480	Etanchéité Taconite sur arbre coté machine Couvercle de protection étanche aux poussières côté opposé
<b>F - K</b>	Hohlwelle für Schrumpfscheibe Hollow shaft for shrink disk Arbre creux pour frette de serrage	Taconite-Dichtung an der Arbeitsmaschinenwelle gegenüberliegende Seite mit staubdichter Schutzhaube Taconite seal on driven machine shaft Dustproof guard on opposite side  Etanchéité Taconite sur arbre coté machine Couvercle de protection étanche aux poussières côté opposé

**Tabelle / Table / Tableau 3**

**G<sub>1</sub> Maß und Wellenabmessungen bei Taconite "E"**  
**G<sub>1</sub> dimension and shaft dimensions for Taconite "E"**  
**Dimension G<sub>1</sub> et dimensions des arbres pour Taconite "E"**

Bauart Type	Größe Size Taille	Übersetzung Ratio / Rapport i	G <sub>1</sub>	d <sub>1</sub> mm	l <sub>1</sub>
<b>H3..</b>	<b>9</b>	25 - 45	250	60 m6	105
		50 - 63		45 m6	80
		71 - 90		32 m6	60
	<b>10</b>	31.5 - 56	250	60 m6	105
		63 - 80		45 m6	80
		90 - 112		32 m6	60
	<b>11</b>	25 - 45	275	70 m6	100
	<b>12</b>	31.5 - 56	275	70 m6	100
	<b>13</b>	22.4 - 45	340	85 m6	130
		50 - 63		60 m6	105
		71 - 90		50 m6	80
	<b>14</b>	28 - 56	340	85 m6	130
		63 - 80		60 m6	105
		90 - 112		50 m6	80
	<b>15</b>	22.4 - 45	385	100 m6	165
		50 - 63		75 m6	105
		71 - 90		60 m6	105
	<b>16</b>	25 - 50	385	100 m6	165
56 - 71		75 m6		105	
80 - 100		60 m6		105	
<b>17</b>	22.4 - 45	415	100 m6	165	
	50 - 63		75 m6	105	
	71 - 90		60 m6	105	
<b>18</b>	25 - 50	415	100 m6	165	
	56 - 71		75 m6	105	
	80 - 100		60 m6	105	
<b>H4..</b>	<b>11</b>	100 - 180	270	45 m6	80
		200 - 355		32 m6	60
	<b>12</b>	125 - 224	270	45 m6	80
		250 - 450		32 m6	60
	<b>13</b>	100 - 180	325	50 m6	80
		200 - 355		38 m6	60
<b>14</b>	125 - 224	325	50 m6	80	
	250 - 450		38 m6	60	
<b>15</b>	100 - 180	375	60 m6	105	
	200 - 355		50 m6	80	
<b>16</b>	112 - 200	375	60 m6	105	
	224 - 400		50 m6	80	

Anbaumaße für  
IEC-Normmotoren

Fitting Dimensions for  
IEC Standard Motors

Côtes de fixation pour  
moteur selon norme IEC

K20/007

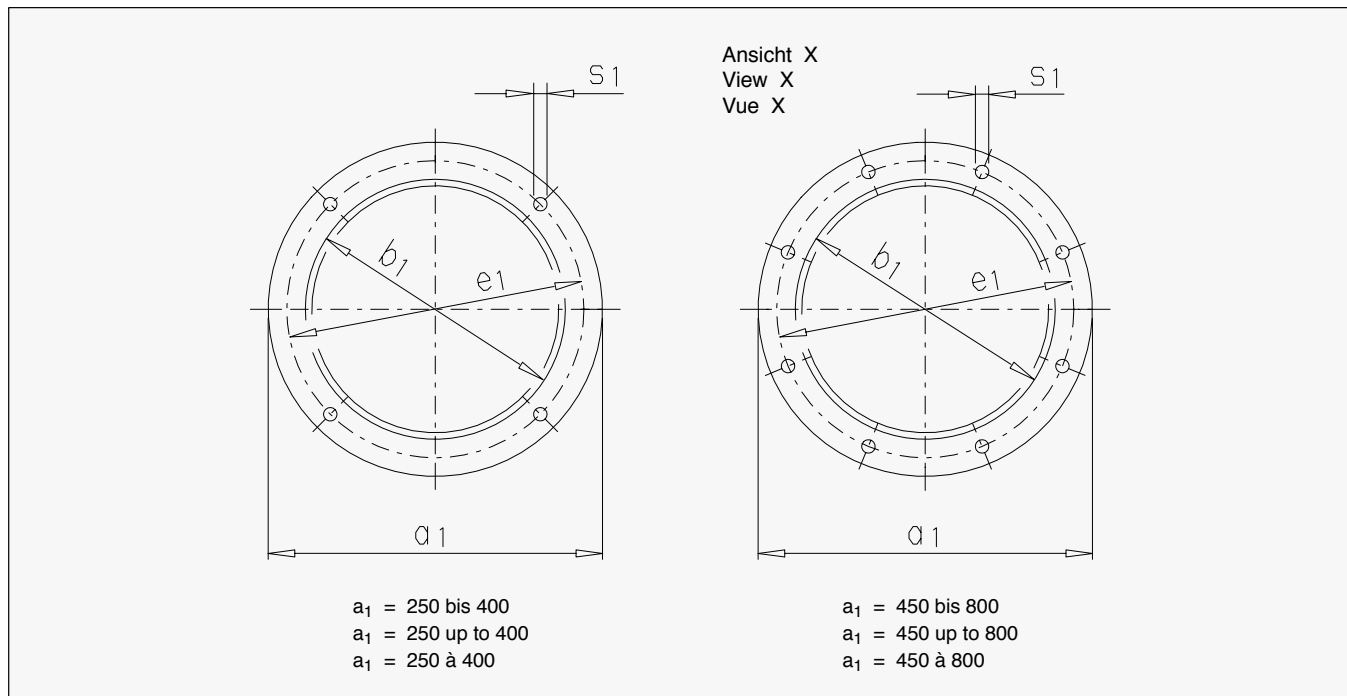

**Tabelle / Table / Tableau 1**

Flanschabmessungen / Flange dimensions / Côtes bride

Drehstrommotoren mit Käfigläufer nach DIN 42677 Teil 1  
Three-phase motors with squirrel-cage rotor acc. to DIN 42677 Part 1  
Moteurs asynchrones triphasés à cage selon DIN 42677 Partie 1

	Motorbaugrößen / Motor sizes / Tailles moteur															
	100 L	112 M	132 S	132 M	160 M	160 L	180 M	180 L	200 L	225 S	225 M	250 M	280 S	280 M	315 S	315 M
$a_1$ mm	250	250	300	300	350	350	350	350	400	450	450	550	550	550	660	660
$b_1$ mm	180	180	230	230	250	250	250	250	300	350	350	450	450	450	550	550
$e_1$ mm	215	215	265	265	300	300	300	300	350	400	400	500	500	500	600	600
$s_1$	4 x M12	4 x M12	4 x M12	4 x M12	4 x M16	4 x M16	4 x M16	4 x M16	4 x M16	4 x M16	8 x M16	8 x M16	8 x M16	8 x M16	8 x M20	8 x M20

Drehstrommotoren mit Käfigläufer (Loher-Bezeichnung)  
Three-phase motors with squirrel-cage rotor (Loher designation)  
Moteurs asynchrones triphasés à cage (Désignation Loher)

	Motorbaugrößen / Motor sizes / Tailles moteur				
	315 MC	315 MD	315 LB	355 MB	355 LB
$a_1$ mm	660	660	660	800	800
$b_1$ mm	550	550	550	680	680
$e_1$ mm	600	600	600	740	740
$s_1$	8 x M20	8 x M20	8 x M20	8 x M20	8 x M20

## Zahnradgetriebe

Motorlaterne für IEC-Motoren  
Bauart H2..  
Größen 4 - 14  
mit BIPEX-Kupplung

## Gear Units

Motor Bell Housing for  
IEC Standard Motors  
Type H2.., Sizes 4 - 14  
with BIPEX Coupling

## Réducteurs à engrenages

Lanterne moteur pour  
moteur selon norme IEC  
Type H2.., Tailles 4 - 14  
avec accouplement BIPEX

K20/007

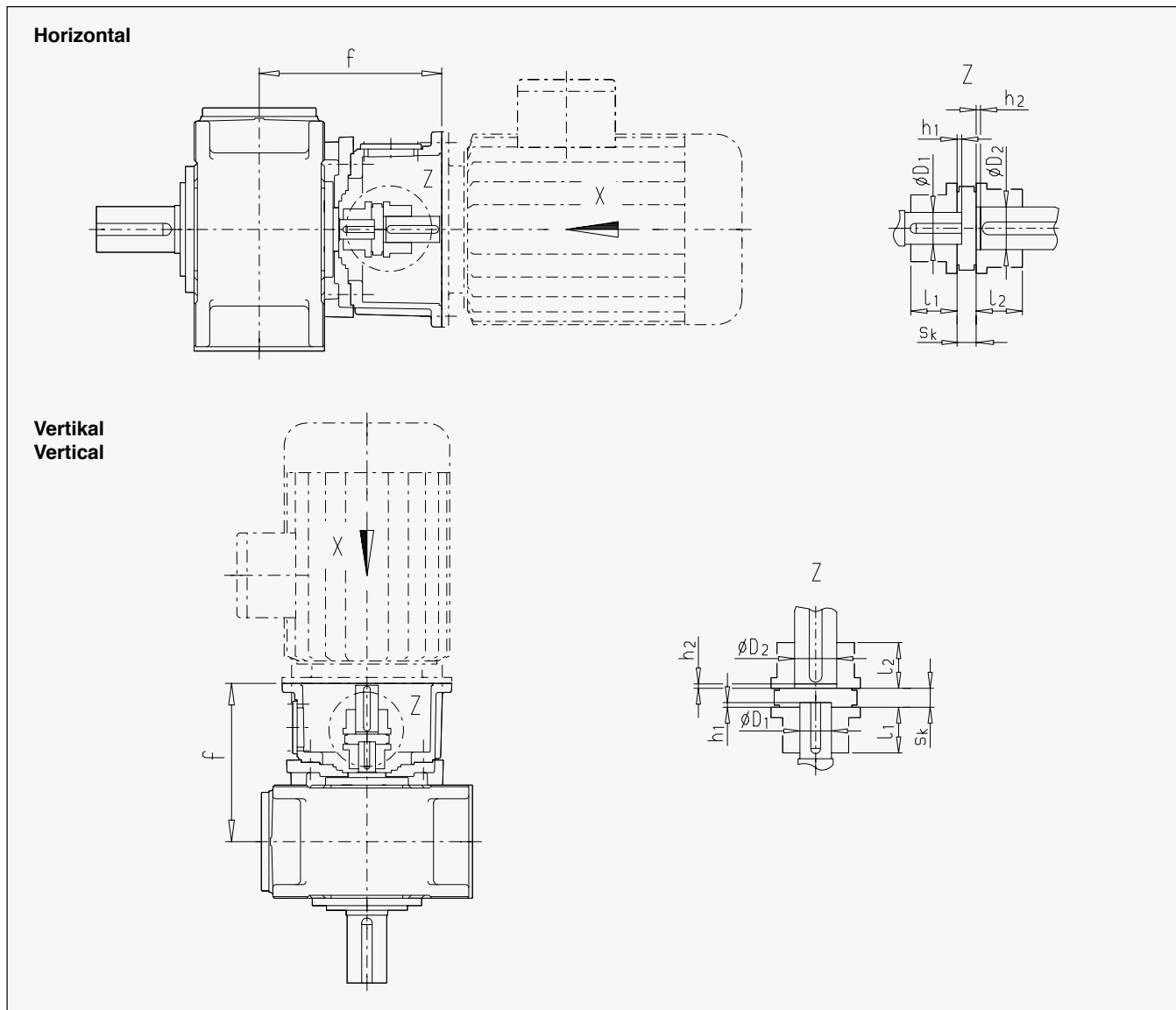

- Bei Anlagen mit besonderen Auslegungsanforderungen (große Schaltfrequenz, wechselnde Lastrichtung; z.B. Hubwerke, Fahrwerke, ...) ist die Auslegung der Kupplung nach dem jeweils gültigen Kupplungskatalog zu prüfen. Bei abweichenden Kupplungen ist Rücksprache mit Flender notwendig!
- For plants with special design requirements (high switching frequency, alternating direction of load; e.g. hoisting gears, travelling gears, etc.) the coupling design is to be checked in accordance with the respective valid coupling brochure. For other couplings, please consult Flender!
- Pour des installations avec des exigences d'exécution spéciales (cadences élevées, inversion de sens de rotation; par exemple réducteurs de levage ou de translation), la sélection de l'accouplement doit être faite en conformité avec le catalogue accouplements en vigueur. Pour d'autres accouplements, veuillez consulter Flender!
- Anbaumaße für IEC-Normmotoren DIN 42677 (Ansicht X) siehe Seite 161.
- For fitting dimensions for IEC standard motors DIN 42677 (View X), see page 161.
- Cotes de fixation pour moteur selon norme IEC DIN 42677 (Vue X) voir page 161.
- Stirnradgetriebe in Ausführung C, D, G, H, I nur auf Anfrage.
- Helical gear unit in C, D, G, H, I design on request only.
- Réducteur cylindrique en exécution C, D, G, H, I seulement sur demande.
- nicht in Verbindung mit Taconite E oder Labyrinth-Abdichtung an der Antriebswelle.
- Not in connection with Taconite E or labyrinth seal on input shaft.
- Exécution pas possible avec joint Taconite E ou labyrinth sur l'arbre d'entrée.

1) andere Motorgrößen auf Anfrage

2) nur Baugröße 315 S und 315 M

4) nur für Vertikalgetriebe

5) Bei Bauart **H2D**. Ausführung A + B; Anbau nicht möglich.

6) Bei Bauart **H2D**. Größe 5 Ausführung A + B; Anbau nicht möglich.

7) Bei Bauart **H2D**. Größe 7 Ausführung A + B; Anbau nicht möglich.

8) Bei Bauart **H2DV** Größe 9 Ausführung A + B; Anbau nicht möglich.

9) Loher-Bezeichnung (Baugrößen nicht in DIN 42677 enthalten).

1) Other motor sizes on request

2) Sizes 315 S and 315 M only

4) For vertical gear units only

5) For type **H2D**. design A + B; fitting not possible.

6) For type **H2D**. size 5 design A + B; fitting not possible.

7) For type **H2D**. size 7 design A + B; fitting not possible.

8) For type **H2DV** size 9 design A + B; fitting not possible.

9) Loher designation (Sizes not included in DIN 42677).

1) Autres tailles sur demande

2) Que pour tailles 315 S et 315 M

4) uniquement pour réducteurs verticaux

5) Pour type **H2D**. exécution A + B; adaptation impossible.

6) Pour type **H2D**. taille 5 exécution A + B; adaptation impossible.

7) Pour type **H2D**. taille 7 exécution A + B; adaptation impossible.

8) Pour type **H2DV** taille 9 exécution A + B; adaptation impossible.

9) Désignation Loher (Tailles hors DIN 42677).

## Zahnradgetriebe

Motorlaterne für IEC-Motoren  
Bauart H2..  
Größen 4 - 14  
mit BIPEX-Kupplung

## Gear Units

Motor Bell Housing for  
IEC Standard Motors  
Type H2..., Sizes 4 - 14  
with BIPEX Coupling

## Réducteurs à engrenages

Lanterne moteur pour  
moteur selon norme IEC  
Type H2..., Tailles 4 - 14  
avec accouplement BIPEX

K20/007

Tabelle / Table / Tableau 2

		Übersetzungen $i_N$ / Ratios $i_N$ / Rapports $i_N$ 6.3 - 11.2 (Größen / Sizes / Tailles 4, 5, 7, 9, 11) 8 - 14 (Größen / Sizes / Tailles 6, 8, 10, 12)										Übersetzungen $i_N$ / Ratios $i_N$ / Rapports $i_N$ 12.5 - 22.4 (Größen / Sizes / Tailles 4, 5, 7, 9, 11) 16 - 28 (Größen / Sizes / Tailles 6, 8, 10, 12)									
Größe Size Taille	Motor Moteur IEC 1)		BIPEX BWN	$s_k$ mm	$l_1$ mm	$D_1$ mm	$l_2$ mm	$D_2$ mm	$h_1$ mm	$h_2$ mm	$f$ mm		BIPEX BWN	$s_k$ mm	$l_1$ mm	$D_1$ mm	$l_2$ mm	$D_2$ mm	$h_1$ mm	$h_2$ mm	$f$ mm
180 5)												97	24	50	32	50	48	14	0	370	
200 5)												112	27	60	32	60	55	11	0	376	
225 5) 4)	127	27	65	45	65	60	20	0	417	4)	127	27	65	32	65	60	0	0	417		
5 / 6	200												112	27	60	38	60	55	10	0	402
	225 6)												127	27	65	38	65	60	- 1	0	443
	250 5) 4)	127	27	65	50	65	65	17.5	0	444.5	4)	127	27	65	38	65	65	- 2.5	0	444.5	
7 / 8	225												127	27	65	50	65	60	13.5	0	473.5
	250 7)												127	27	65	50	65	65	12	0	475
	280 7)												142	31	75	50	75	75	- 3	0	494
	315 2) 5) 4)	162	36	80	60	80	80	20	0	531	4)	162	36	80	50	80	80	- 2.5	2.5	531	
9 / 10	280												142	31	75	60	75	75	22	0	530
	315 2) 8) 4)	162	36	80	75	80	80	20	0	566	4)	162	36	80	60	80	80	20	0	566	
11 / 12	315 2)												162	36	80	70	80	80	15	0	606

Tabelle / Table / Tableau 3

		Übersetzungen $i_N$ / Ratios $i_N$ / Rapports $i_N$ 12.5 - 20 (Größe / Size / Taille 13) 16 - 25 (Größe / Size / Taille 14)									
Größe Size Taille	Motor Moteur IEC 1)		BIPEX BWN	$s_k$ mm	$l_1$ mm	$D_1$ mm	$l_2$ mm	$D_2$ mm	$h_1$ mm	$h_2$ mm	$f$ mm
355 LB 9)	4)	227	54	110	85	110	90	6	0	718	

## Zahnradgetriebe

Motorlaterne für IEC-Motoren  
Bauart H3..  
Größen 5 - 18  
mit BIPEX-Kupplung

## Gear Units

Motor Bell Housing for  
IEC Standard Motors  
Type H3., Sizes 5 - 18  
with BIPEX Coupling

## Réducteurs à engrenages

Lanterne moteur pour  
moteur selon norme IEC  
Type H3., Tailles 5 - 18  
avec accouplement BIPEX

K20/007

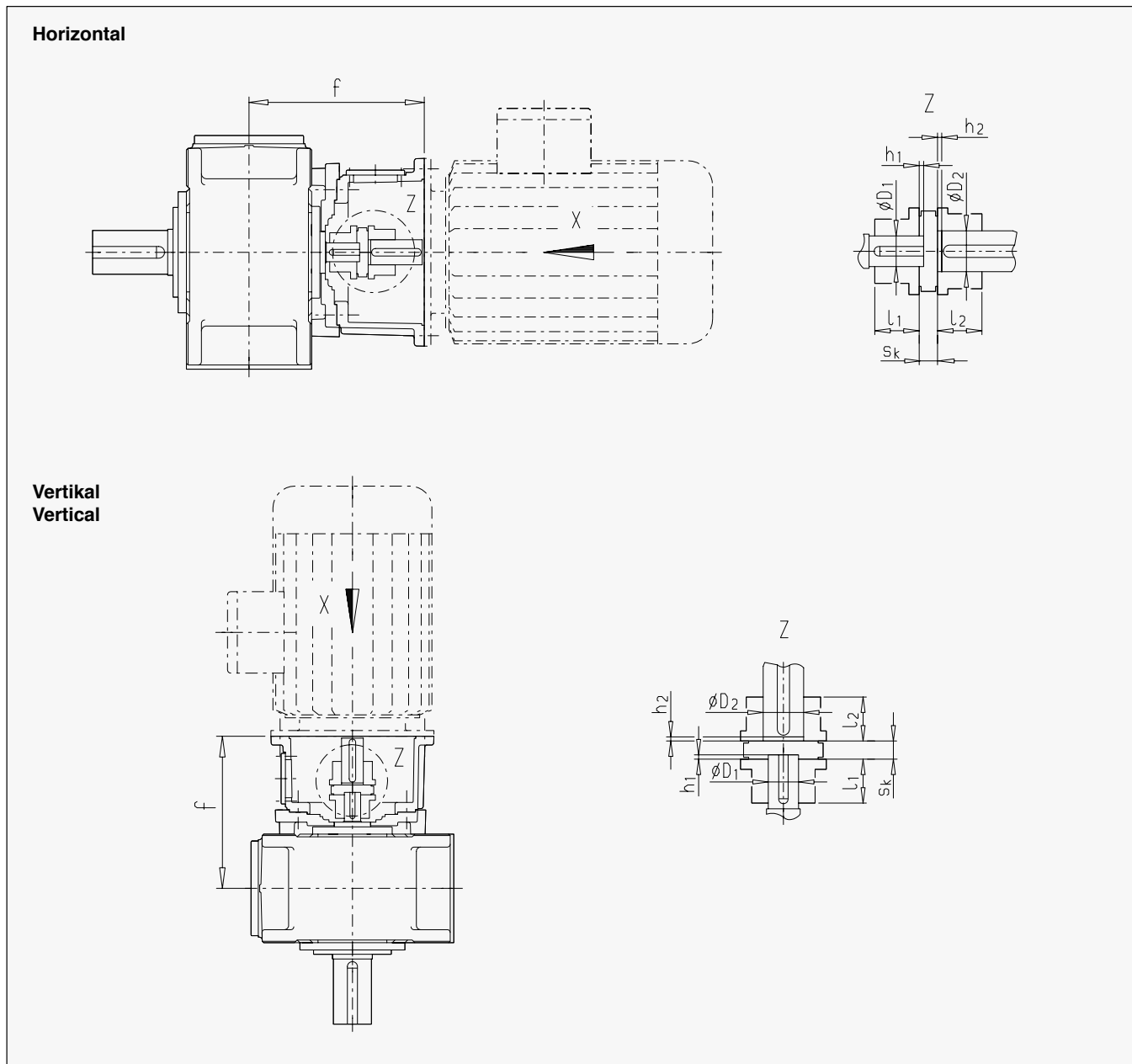

- Bei Anlagen mit besonderen Auslegungsanforderungen (große Schalthäufigkeit, wechselnde Lastrichtung; z.B. Hubwerke, Fahrwerke, ...) ist die Auslegung der Kupplung nach dem jeweils gültigen Kupplungskatalog zu prüfen. Bei abweichenden Kupplungen ist Rücksprache mit Flender notwendig!
- For plants with special design requirements (high switching frequency, alternating direction of load; e.g. hoisting gears, travelling gears, etc.) the coupling design is to be checked in accordance with the respective valid coupling brochure. For other couplings, please consult Flender!
- Pour des installations avec des exigences d'exécution spéciales (cadences élevées, inversion de sens de rotation; par exemple réducteurs de levage ou de translation), la sélection de l'accouplement doit être faite en conformité avec le catalogue accouplements en vigueur. Pour d'autres accouplements, veuillez consulter Flender!
- Anbaumaße für IEC-Normmotoren DIN 42677 (Ansicht X) siehe Seite 161.
- For fitting dimensions for IEC standard motors DIN 42677 (View X), see page 161.
- Cotes de fixation pour moteur selon norme IEC DIN 42677 (Vue X) voir page 161.
- Stirnradgetriebe in Ausführung G, H, I nur auf Anfrage.
- Helical gear unit in G, H, I design on request only.
- Réducteur cylindrique en exécution G, H, I seulement sur demande.
- nicht in Verbindung mit Taconite E oder Labyrinth-Abdichtung an der Antriebswelle.
- Not in connection with Taconite E or labyrinth seal on input shaft.
- Exécution pas possible avec joint Taconite E ou labyrinthe sur l'arbre d'entrée.

- 1) andere Motorgrößen auf Anfrage
- 1) Other motor sizes on request
- 1) Autres tailles sur demande
- 2) nur Baugröße 315 S und 315 M
- 2) Sizes 315 S and 315 M only
- 2) Que pour tailles 315 S et 315 M
- 3) Länge  $l_1$  der Kupplungsnabe zum Aufsetzen auf Getriebewelle gekürzt.
- 3) Length  $l_1$  of coupling hub shortened for fitting onto gear unit shaft.
- 3) Longueur  $l_1$  du moyeu d'accouplement raccourcie pour montage sur l'arbre du réducteur.
- 4) nur für Vertikalgetriebe
- 4) For vertical gear units only
- 4) uniquement pour réducteurs verticaux
- 9) Loher-Bezeichnung (Baugrößen nicht in DIN 42677 enthalten).
- 9) Loher designation (Sizes not included in DIN 42677).
- 9) Désignation Loher (Tailles hors DIN 42677).



# Zahnradgetriebe

Motorlaterne für IEC-Motoren  
 Bauart H3..  
 Größen 5 - 18  
 mit BIPEX-Kupplung

# Gear Units

Motor Bell Housing for  
 IEC Standard Motors  
 Type H3.., Sizes 5 - 18  
 with BIPEX Coupling

# Réducteurs à engrenages

Lanterne moteur pour  
 moteur selon norme IEC  
 Type H3.., Tailles 5 - 18  
 avec accouplement BIPEX

K20/007

Tabelle / Table / Tableau 4

Größe Size Taille	Motor Moteur IEC 1)	Übersetzungen $i_N$ / Ratios $i_N$ / Rappports $i_N$ 25 - 45 (Größen / Sizes / Tailles 5, 7, 9, 11) 31.5 - 56 (Größen / Sizes / Tailles 6, 8, 10, 12) 22.4 - 45 (Größen / Sizes / Tailles 13, 15, 17) 28 - 56 (Größe / Size / Taille 14) 25 - 50 (Größen / Sizes / Tailles 16, 18)										Übersetzungen $i_N$ / Ratios $i_N$ / Rappports $i_N$ 50 - 63 (Größen / Sizes / Tailles 5, 7, 9, 11) 63 - 80 (Größen / Sizes / Tailles 6, 8, 10, 12) 50 - 63 (Größen / Sizes / Tailles 13, 15, 17) 63 - 80 (Größe / Size / Taille 14) 56 - 71 (Größen / Sizes / Tailles 16, 18)										Übersetzungen $i_N$ / Ratios $i_N$ / Rappports $i_N$ 71 - 90 (Größen / Sizes / Tailles 5, 7, 9, 11) 90 - 112 (Größen / Sizes / Tailles 6, 8, 10, 12) 71 - 90 (Größen / Sizes / Tailles 13, 15, 17) 90 - 112 (Größe / Size / Taille 14) 80 - 100 (Größen / Sizes / Tailles 16, 18)									
		BIPEX BWN	$s_k$ mm	$l_1$ mm	$D_1$ mm	$l_2$ mm	$D_2$ mm	$h_1$ mm	$h_2$ mm	f mm	BIPEX BWN	$s_k$ mm	$l_1$ mm	$D_1$ mm	$l_2$ mm	$D_2$ mm	$h_1$ mm	$h_2$ mm	f mm	BIPEX BWN	$s_k$ mm	$l_1$ mm	$D_1$ mm	$l_2$ mm	$D_2$ mm	$h_1$ mm	$h_2$ mm	f mm			
		5 / 6	132																			72	18	35	24	35	38	-2	-2	302	
160	84		21	40	40	40	42	-1.5	1.5	364	84	21	40	30	40	42	3	0	338	84	21	40	24	40	42	-7	0	338			
180	97		24	50	40	50	48	0	0	364	<sup>3)</sup> 97	24	44	30	50	48	6	0	338	<sup>3)</sup> 97	24	44	24	50	48	-4	0	338			
200	<sup>3)</sup> 112		27	53	40	60	55	17	0	350	<sup>3)</sup> 112	27	53	30	60	55	-3	0	350												
225	<sup>3)</sup> 127		27	60	40	65	60	6	0	391																					
250	<sup>3)</sup> <sup>4)</sup> 127		27	60	40	65	65	6	0	391																					
7 / 8	160																			84	21	40	28	40	42	-1	0	367			
	180										<sup>3)</sup> 97	24	45	35	50	48	12	0	367	<sup>3)</sup> 97	24	45	28	50	48	2	0	367			
	200	112	27	60	45	60	55	-1.5	1.5	405	<sup>3)</sup> 112	27	55	35	60	55	3	0	379	<sup>3)</sup> 112	27	55	28	60	55	-7	0	379			
	225	127	27	65	45	65	60	12	0	420	127	27	65	35	65	60	-8	0	420	127	27	65	28	65	60	-18	0	420			
	250	127	27	65	45	65	65	12	0	420	127	27	65	35	65	65	-8	0	420												
	280	142	31	75	45	75	75	-4.5	0	440.5																					
	315	<sup>2)</sup> <sup>4)</sup> 162	36	80	45	80	80	-6.5	0	477.5																					
9 / 10	180																			97	24	50	32	50	48	12.5	0	431.5			
	200																			112	27	60	32	60	55	3.5	0	443.5			
	225	127	27	65	60	65	60	2.5	0	519.5	127	27	65	45	65	60	12.5	0	484.5	127	27	65	32	65	60	-3.75	-3.75	484.5			
	250	127	27	65	60	65	65	2.5	0	519.5	127	27	65	45	65	65	12.5	0	484.5	127	27	65	32	65	65	-3.75	-3.75	484.5			
	280	142	31	75	60	75	75	21	0	505	142	31	75	45	75	75	-2	2	505												
	315	<sup>2)</sup> <sup>4)</sup> 162	36	80	60	80	80	19	0	545	<sup>4)</sup> 162	36	80	45	80	80	-3	3	542												
11 / 12	225																			127	27	65	42	65	60	2.5	0	489.5			
	250										127	27	65	50	65	65	12.5	0	489.5	127	27	65	42	65	65	2.5	0	489.5			
	280	142	31	75	70	75	75	6	0	540	142	31	75	50	75	75	-4	0	510	142	31	75	42	75	75	-7	-7	510			
	315	<sup>2)</sup> 162	36	80	70	80	80	4	0	577	162	36	80	50	80	80	-6	0	547	162	36	80	42	80	80	-16	0	547			
13 / 14	250																			127	27	65	50	65	65	8.5	0	578.5			
	280										142	31	75	60	75	75	17	0	599	142	31	75	50	75	75	-4	4	599			
	315	<sup>2)</sup> 182	42	90	85	90	80	13	-3	666	162	36	80	60	80	80	15	0	636	162	36	80	50	80	80	-5	5	636			
	315 MC <sup>9)</sup>	182	42	90	85	90	80	13	-3	666	182	42	90	60	90	80	21	0	636	182	42	90	50	90	80	0	4	636			
	315 MD <sup>9)</sup>	182	42	90	85	90	80	13	-3	666	182	42	90	60	90	80	21	0	636	182	42	90	50	90	80	0	4	636			
	315 LB <sup>9)</sup>	202	48	100	85	100	80	22	0	666	202	48	100	60	100	80	22	-5	636	202	48	100	50	100	80	0	-2	636			
	355 MB <sup>9)</sup>	202	48	100	85	100	90	20	0	668	202	48	100	60	100	90	-2.5	2.5	668												
	355 LB <sup>9)</sup>	227	54	110	85	110	90	26	0	668																					
15 / 16	280																			142	31	75	60	75	75	14	0	647			
	315	<sup>2)</sup> 162	36	80	75	80	80	12	0	684	162	36	80	75	80	80	12	0	684	162	36	80	60	80	80	12	0	684			
	315 MC <sup>9)</sup>										182	42	90	75	90	80	18	0	684	182	42	90	60	90	80	18	0	684			
	315 MD <sup>9)</sup>										182	42	90	75	90	80	18	0	684	182	42	90	60	90	80	18	0	684			
	315 LB <sup>9)</sup>	202	48	100	100	100	80	4	0	764	202	48	100	75	100	80	24	0	684	202	48	100	60	100	80	24	0	684			
	355 MB <sup>9)</sup>	202	48	100	100	100	90	0	0	768	202	48	100	75	100	90	-4	4	716	202	48	100	60	100	90	-4	4	716			
	355 LB <sup>9)</sup>	227	54	110	100	110	90	6	0	768	227	54	110	75	110	90	-2	0	716	227	54	110	60	110	90	-2	0	716			
17 / 18	315	<sup>2)</sup> 162	36	80	60	80	80	12	0	714											162	36	80	60	80	80	12	0	714		
	315 MC <sup>9)</sup>										182	42	90	60	80	80	18	0	714	182	42	90	60	80	80	18	0	714			
	315 MD <sup>9)</sup>										182	42	90	60	90	80	18	0	714	182	42	90	60	90	80	18	0	714			
	315 LB <sup>9)</sup>										202	48	100	75	100	80	24	0	714	202	48	100	60	100	80	24	0	714			
	355 MB <sup>9)</sup>	202	48	100	100	100	90	0	0	798	202	48	100	75	100	90	-4	4	746	202	48	100	60	100	90	-4	4	746			
	355 LB <sup>9)</sup>	227	54	110	100	110	90	6	0	798	227	54	110	75	110	90	-2	0	746	227	54	110	60	110	90	-2	0	746			

## Zahnradgetriebe

Motorlaterne für IEC-Motoren  
Bauart H4..  
Größen 7 - 18  
mit BIPEX-Kupplung

## Gear Units

Motor Bell Housing for  
IEC Standard Motors  
Type H4.., Sizes 7 - 18  
with BIPEX Coupling

## Réducteurs à engrenages

Lanterne moteur pour  
moteur selon norme IEC  
Type H4.., Tailles 7 - 18  
avec accouplement BIPEX

K20/007

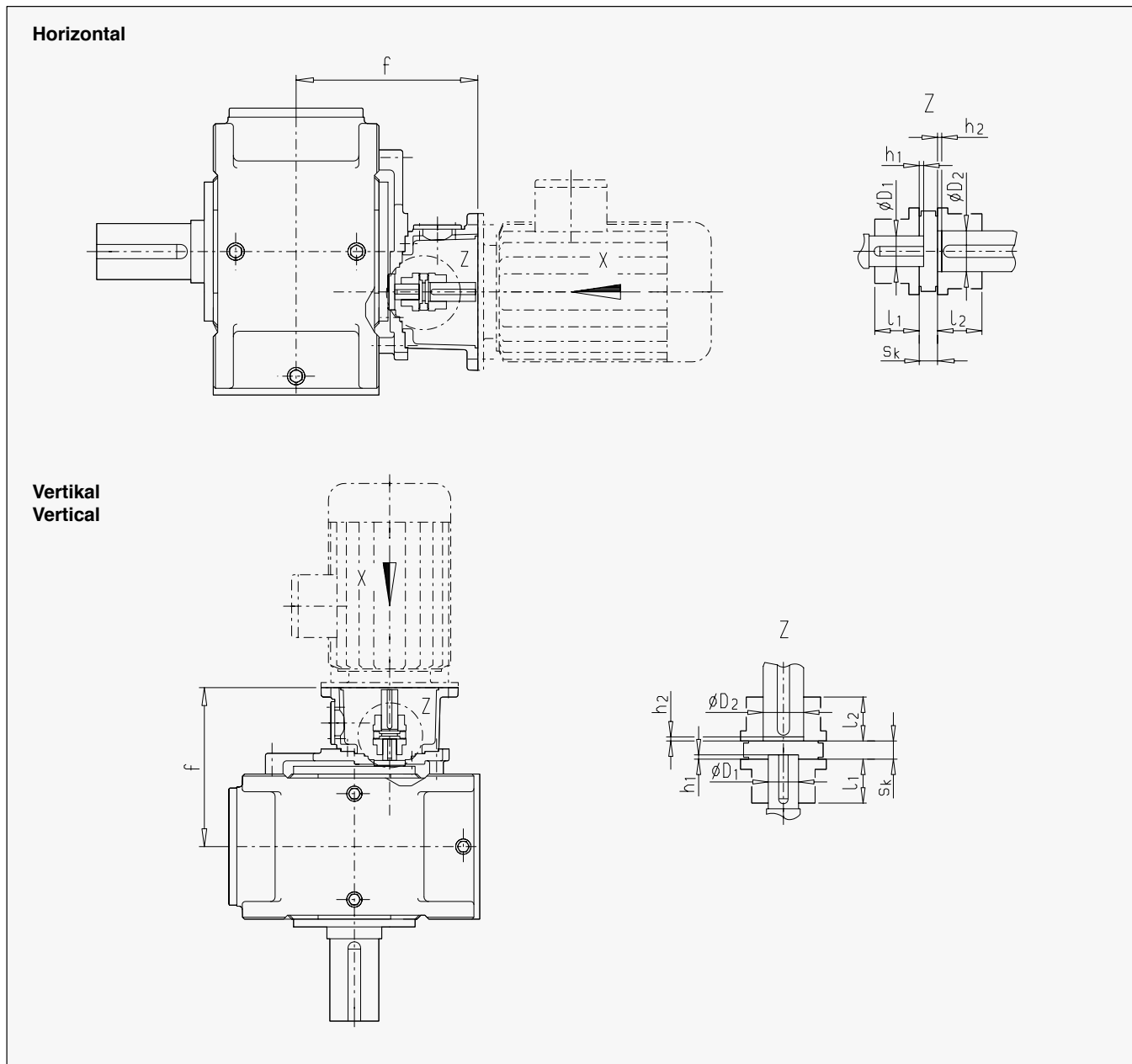

- Bei Anlagen mit besonderen Auslegungsanforderungen (große Schalthäufigkeit, wechselnde Lastrichtung; z.B. Hubwerke, Fahrwerke, ...) ist die Auslegung der Kupplung nach dem jeweils gültigen Kupplungskatalog zu prüfen. Bei abweichenden Kupplungen ist Rücksprache mit Flender notwendig!
- For plants with special design requirements (high switching frequency, alternating direction of load; e.g. hoisting gears, travelling gears, etc.) the coupling design is to be checked in accordance with the respective valid coupling brochure. For other couplings, please consult Flender!
- Pour des installations avec des exigences d'exécution spéciales (cadences élevées, inversion de sens de rotation; par exemple réducteurs de levage ou de translation), la sélection de l'accouplement doit être faite en conformité avec le catalogue accouplements en vigueur. Pour d'autres accouplements, veuillez consulter Flender!
- Anbaumaße für IEC-Normmotoren DIN 42677 (Ansicht X) siehe Seite 161.
- For fitting dimensions for IEC standard motors DIN 42677 (View X), see page 161.
- Cotes de fixation pour moteur selon norme IEC DIN 42677 (Vue X) voir page 161.
- Stirnradgetriebe in Ausführung G, H, I nur auf Anfrage.
- Helical gear unit in G, H, I design on request only.
- Réducteur cylindrique en exécution G, H, I seulement sur demande.
- nicht in Verbindung mit Taconite E oder Labyrinth-Abdichtung an der Antriebswelle.
- Not in connection with Taconite E or labyrinth seal on input shaft.
- Exécution pas possible avec joint Taconite E ou labyrinthe sur l'arbre d'entrée.

- 1) andere Motorgrößen auf Anfrage
- 1) Other motor sizes on request
- 1) Autres tailles sur demande
- 2) nur Baugröße 315 S und 315 M
- 2) Sizes 315 S and 315 M only
- 2) Que pour tailles 315 S et 315 M
- 3) Länge  $l_1$  der Kupplungsnabe zum Aufsetzen auf Getriebewelle gekürzt.
- 3) Length  $l_1$  of coupling hub shortened for fitting onto gear unit shaft.
- 3) Longueur  $l_1$  du moyeu d'accouplement raccourcie pour montage sur l'arbre du réducteur.
- 9) Loher-Bezeichnung (Baugrößen nicht in DIN 42677 enthalten).
- 9) Loher designation (Sizes not included in DIN 42677).
- 9) Désignation Loher (Tailles hors DIN 42677).

## Zahnradgetriebe

Motorlaterne für IEC-Motoren  
Bauart H4..  
Größen 7 - 18  
mit BIPEX-Kupplung

## Gear Units

Motor Bell Housing for  
IEC Standard Motors  
Type H4..., Sizes 7 - 18  
with BIPEX Coupling

## Réducteurs à engrenages

Lanterne moteur pour  
moteur selon norme IEC  
Type H4..., Tailles 7 - 18  
avec accouplement BIPEX

K20/007

Tabelle / Table / Tableau 5

Größe Size Taille	Motor Moteur IEC 1)	Übersetzungen $i_N$ / Ratios $i_N$ / Rapports $i_N$ 100 - 180 (Größen / Sizes / Tailles 7, 9, 11) 125 - 224 (Größen / Sizes / Tailles 8, 10, 12) 100 - 180 (Größen / Sizes / Tailles 13, 15, 17) 125 - 224 (Größe / Size / Taille 14) 112 - 200 (Größen / Sizes / Tailles 16, 18)									Übersetzungen $i_N$ / Ratios $i_N$ / Rapports $i_N$ 200 - 355 (Größen / Sizes / Tailles 7, 9, 11) 250 - 450 (Größen / Sizes / Tailles 8, 10, 12) 200 - 355 (Größen / Sizes / Tailles 13, 15, 17) 250 - 450 (Größe / Size / Taille 14) 224 - 400 (Größen / Sizes / Tailles 16, 18)										
		BIPEX BWN	$s_k$ mm	$l_1$ mm	$D_1$ mm	$l_2$ mm	$D_2$ mm	$h_1$ mm	$h_2$ mm	f mm	BIPEX BWN	$s_k$ mm	$l_1$ mm	$D_1$ mm	$l_2$ mm	$D_2$ mm	$h_1$ mm	$h_2$ mm	f mm		
7 / 8	100										62	16	30	24	30	28	0	0	296		
	112										62	16	30	24	30	28	0	0	296		
	132		72	18	35	30	35	38	-0.5	0	328.5	72	18	35	24	35	38	-5.5	5	328.5	
	160		84	21	40	30	40	42	-3.5	0	364.5	84	21	40	24	40	42	-6.5	7	364.5	
	180	3)	97	24	42	30	50	48	-0.5	0	364.5										
9 / 10	132										72	18	35	28	35	38	-3.5	3	369.5		
	160		84	21	40	35	40	42	0.5	0	405.5	84	21	40	28	40	42	-4.5	5	405.5	
	180	3)	97	24	47	35	50	48	3.5	0	405.5	3)	97	24	47	28	50	48	-6.5	0	405.5
	200	3)	112	27	54	35	60	55	-5.5	0	417.5										
	225	3)	127	27	59	35	65	60	-10	6.5	458.5										
11 / 12	160										84	21	40	32	40	42	13.5	0	447.5		
	180		97	24	50	45	50	48	10.5	0	437.5	97	24	50	32	50	48	16.5	0	447.5	
	200		112	27	60	45	60	55	1.5	0	485.5	112	27	60	32	60	55	7.5	0	459.5	
	225		127	27	65	45	65	60	16.5	0	500.5	127	27	65	32	65	60	0	3.5	500.5	
	250		127	27	65	45	65	65	16.5	0	500.5										
13 / 14	160										84	21	40	38	40	42	0	1.5	517.5		
	180										97	24	50	38	50	48	1.5	0	517.5		
	200		127	27	65	50	65	55	12.5	0	529.5	112	27	50	38	60	55	18.5	0	503.5	
	225		127	27	65	50	65	60	-3.5	4	579.5	127	27	61	38	65	60	7.5	0	544.5	
	250		127	27	65	50	65	65	-3.5	4	579.5	127	27	61	38	65	65	7.5	0	544.5	
	280		142	31	75	50	75	75	11	0	565										
	315 2)		162	36	75	50	80	80	9	0	602										
15 / 16	200										112	27	60	50	60	55	-3	3.5	598.5		
	225		127	27	65	60	65	60	-1.5	0	648.5	127	27	65	50	65	60	8.5	0	613.5	
	250		127	27	65	60	65	65	-1.5	0	648.5	127	27	65	50	65	65	8.5	0	613.5	
	280		142	31	75	60	75	75	17	0	634	142	31	75	50	75	75	-4	4	634	
	315 2)		162	36	80	60	80	80	15	0	671	162	36	80	50	80	80	-5	5	671	
	315 MC 9)		182	42	90	60	90	80	21	0	671										
	315 MD 9)		182	42	90	60	90	80	21	0	671										
315 LB 9)		202	48	100	60	100	80	20	-7	671											
17 / 18	225										127	27	65	50	65	60	3.5	0	623.5		
	250										127	27	65	50	65	65	3.5	0	623.5		
	280		142	31	75	60	75	75	12	0	644	142	31	75	50	75	75	-6.5	6.5	644	
	315 2)		162	36	80	60	80	80	10	0	681	162	36	80	50	80	80	-5	10	681	
	315 MC 9)		182	42	90	60	90	80	10	-6	681										
	315 MD 9)		182	42	90	60	90	80	10	-6	681										
	315 LB 9)		202	48	100	60	100	80	-4	4	711										
355 MB 9)		202	48	100	60	100	90	-5	5	713											

## Zahnradgetriebe

Motorlaterne für IEC-Motoren  
Bauart B2..  
Größen 4 - 14  
mit BIPEX-Kupplung

## Gear Units

Motor Bell Housing for  
IEC Standard Motors  
Type B2.., Sizes 4 - 14  
with BIPEX Coupling

## Réducteurs à engrenages

Lanterne moteur pour  
moteur selon norme IEC  
Type B2.., Tailles 4 - 14  
avec accouplement BIPEX

K20/007

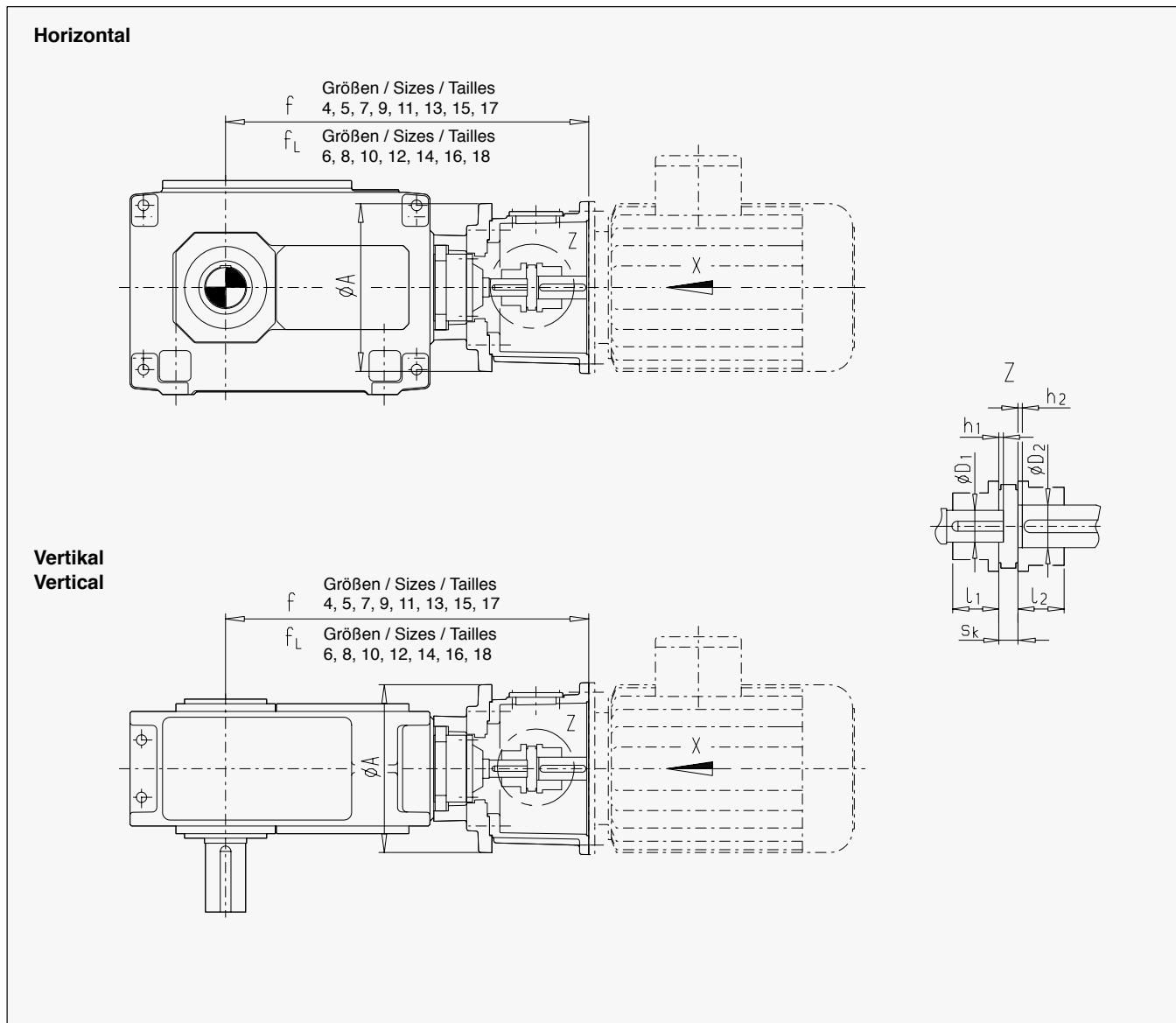

- Bei Anlagen mit besonderen Auslegungsanforderungen (große Schalthäufigkeit, wechselnde Lastichtung; z.B. Hubwerke, Fahrwerke, ...) ist die Auslegung der Kupplung nach dem jeweils gültigen Kupplungskatalog zu prüfen. Bei abweichenden Kupplungen ist Rücksprache mit Flender notwendig!
- Anbaumaße für IEC-Normmotoren DIN 42677 (Ansicht X) siehe Seite 161.
- nicht in Verbindung mit Taconite E oder Labyrinth-Abdichtung an der Antriebswelle.
- For plants with special design requirements (high switching frequency, alternating direction of load; e.g. hoisting gears, travelling gears, etc.) the coupling design is to be checked in accordance with the respective valid coupling brochure. For other couplings, please consult Flender!
- For fitting dimensions for IEC standard motors DIN 42677 (View X), see page 161.
- Not in connection with Taconite E or labyrinth seal on input shaft.
- Pour des installations avec des exigences d'exécution spéciales (cadences élevées, inversion de sens de rotation; par exemple réducteurs de levage ou de translation), la sélection de l'accouplement doit être faite en conformité avec le catalogue accouplements en vigueur. Pour d'autres accouplements, veuillez consulter Flender!
- Cotes de fixation pour moteur selon norme IEC DIN 42677 (Vue X) voir page 161.
- Exécution pas possible avec joint Taconite E ou labyrinth sur l'arbre d'entrée.

1) andere Motorgrößen auf Anfrage

2) nur Baugröße 315 S und 315 M

9) Loher-Bezeichnung

(Baugrößen nicht in DIN 42677 enthalten).

1) Other motor sizes on request

2) Sizes 315 S and 315 M only

9) Loher designation

(Sizes not included in DIN 42677).

1) Autres tailles sur demande

2) Que pour tailles 315 S et 315 M

9) Désignation Loher

(Tailles hors DIN 42677).

## Zahnradgetriebe

Motorlaterne für IEC-Motoren  
Bauart B2..  
Größen 4 - 14  
mit BIPEX-Kupplung

## Gear Units

Motor Bell Housing for  
IEC Standard Motors  
Type B2.., Sizes 4 - 14  
with BIPEX Coupling

## Réducteurs à engrenages

Lanterne moteur pour  
moteur selon norme IEC  
Type B2.., Tailles 4 - 14  
avec accouplement BIPEX

K20/007

Tabelle / Table / Tableau 6

Größe Size Taille	Motor Moteur IEC 1)	Übersetzungen $i_N$ / Ratios $i_N$ / Rapports $i_N$ 5 - 11.2 (Größen / Sizes / Tailles 4, 5, 7, 9, 11) 6.3 - 14 (Größen / Sizes / Tailles 6, 8, 10, 12)											Übersetzungen $i_N$ / Ratios $i_N$ / Rapports $i_N$ 12.5 - 18 (Größen / Sizes / Tailles 4, 5, 7, 9, 11) 16 - 22.4 (Größen / Sizes / Tailles 6, 8, 10, 12)										
		BIPEX BWN	$s_k$ mm	$l_1$ mm	$D_1$ mm	$l_2$ mm	$D_2$ mm	$h_1$ mm	$h_2$ mm	$f$ mm	$f_L$ mm	A mm	BIPEX BWN	$s_k$ mm	$l_1$ mm	$D_1$ mm	$l_2$ mm	$D_2$ mm	$h_1$ mm	$h_2$ mm	$f$ mm	$f_L$ mm	A mm
4	180												97	24	50	35	50	48	0.5	0	678.5	-	350
	200	112	27	60	45	60	55	17.5	0	684.5	-	350	112	27	60	35	60	55	-2.5	0	684.5	-	350
5 / 6	200												112	27	60	40	60	55	-8.5	0	763.5	798.5	350
	225												127	27	65	40	65	60	-2.5	0	804.5	839.5	350
7 / 8	250												127	27	65	50	65	65	2	0	915	960	440
	280	162	36	80	70	80	75	17	0	934	979	440	142	31	75	50	75	75	-6.5	6.5	934	979	440
9 / 10	280												142	31	75	60	75	75	-4	4	1074	1124	445
11 / 12	315 2)												162	36	80	70	80	80	15	0	1256	1326	520

Tabelle / Table / Tableau 7

Größe Size Taille	Motor Moteur IEC 1)	Übersetzungen $i_N$ / Ratios $i_N$ / Rapports $i_N$ 12.5 - 18 (Größe / Size / Taille 13) 16 - 22.4 (Größe / Size / Taille 14)										
		BIPEX BWN	$s_k$ mm	$l_1$ mm	$D_1$ mm	$l_2$ mm	$D_2$ mm	$h_1$ mm	$h_2$ mm	$f$ mm	$f_L$ mm	A mm
13 / 14	355 MB 9)	202	48	100	80	100	90	1	0	1457	1527	650
	355 LB 9)	227	54	110	80	110	90	7	0	1457	1527	650

## Zahnradgetriebe

Motorlaterne für IEC-Motoren  
Bauart B3..  
Größen 4 - 18  
mit BIPEX-Kupplung

## Gear Units

Motor Bell Housing for  
IEC Standard Motors  
Type B3.., Sizes 4 - 18  
with BIPEX Coupling

## Réducteurs à engrenages

Lanterne moteur pour  
moteur selon norme IEC  
Type B3.., Tailles 4 - 18  
avec accouplement BIPEX

K20/007

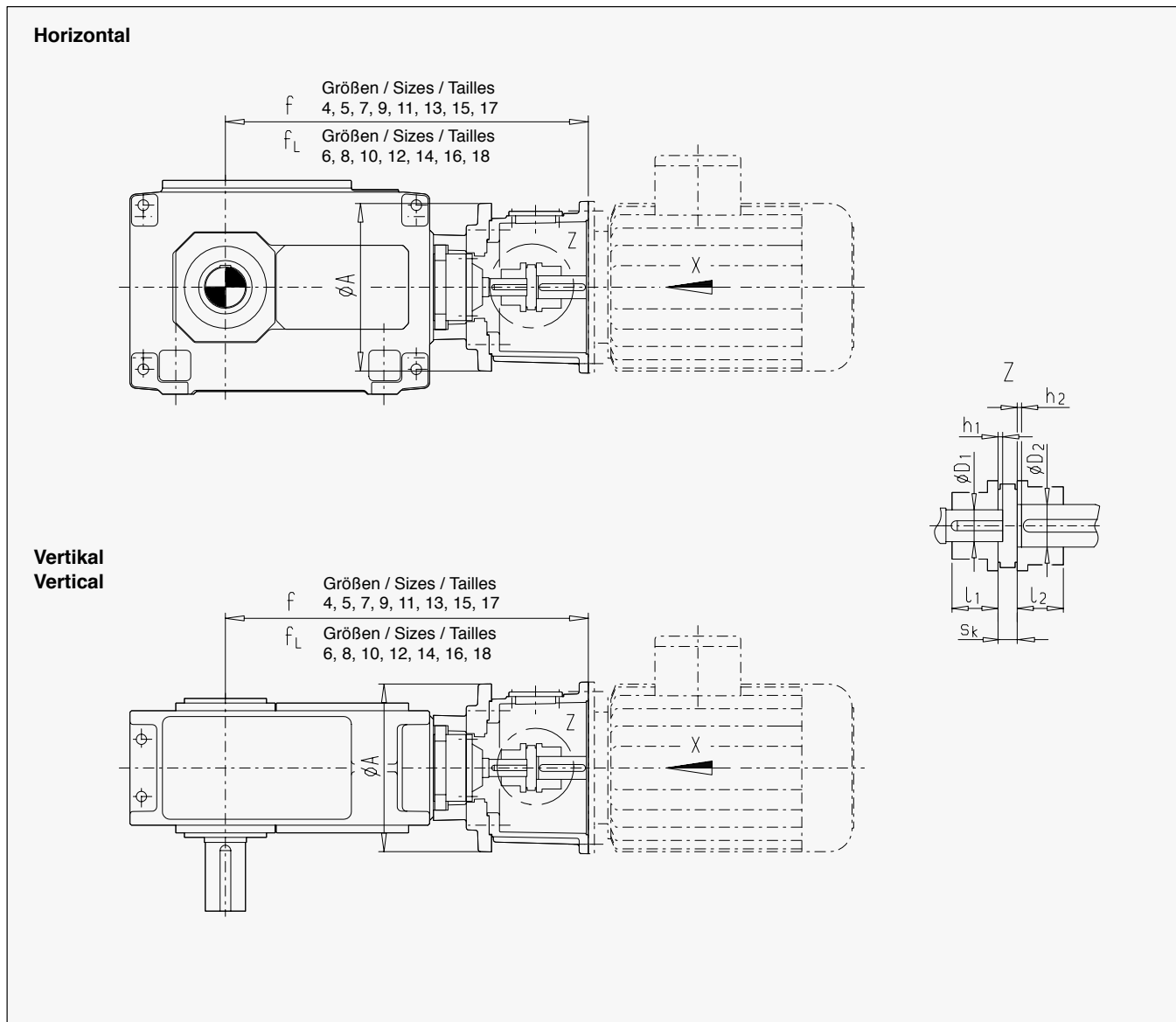

- Bei Anlagen mit besonderen Auslegungsanforderungen (große Schalthäufigkeit, wechselnde Lastrichtung; z.B. Hubwerke, Fahrwerke, ...) ist die Auslegung der Kupplung nach dem jeweils gültigen Kupplungskatalog zu prüfen. Bei abweichenden Kupplungen ist Rücksprache mit Flender notwendig!
- Anbaumaße für IEC-Normmotoren DIN 42677 (Ansicht X) siehe Seite 161.
- nicht in Verbindung mit Taconite E oder Labyrinth-Abdichtung an der Antriebswelle.
- For plants with special design requirements (high switching frequency, alternating direction of load; e.g. hoisting gears, travelling gears, etc.) the coupling design is to be checked in accordance with the respective valid coupling brochure. For other couplings, please consult Flender!
- For fitting dimensions for IEC standard motors DIN 42677 (View X), see page 161.
- Not in connection with Taconite E or labyrinth seal on input shaft.
- Pour des installations avec des exigences d'exécution spéciales (cadences élevées, inversion de sens de rotation; par exemple réducteurs de levage ou de translation), la sélection de l'accouplement doit être faite en conformité avec le catalogue accouplements en vigueur. Pour d'autres accouplements, veuillez consulter Flender!
- Cotes de fixation pour moteur selon norme IEC DIN 42677 (Vue X) voir page 161.
- Exécution pas possible avec joint Taconite E ou labyrinth sur l'arbre d'entrée.

- 1) andere Motorgrößen auf Anfrage
- 2) nur Baugröße 315 S und 315 M
- 3) Länge  $l_1$  der Kupplungsnahe zum Aufsetzen auf Getriebewelle gekürzt.
- 9) Loher-Bezeichnung (Baugrößen nicht in DIN 42677 enthalten).
- 1) Other motor sizes on request
- 2) Sizes 315 S and 315 M only
- 3) Length  $l_1$  of coupling hub shortened for fitting onto gear unit shaft.
- 9) Loher designation (Sizes not included in DIN 42677).
- 1) Autres tailles sur demande
- 2) Que pour tailles 315 S et 315 M
- 3) Longueur  $l_1$  du moyeu d'accouplement raccourcie pour montage sur l'arbre du réducteur.
- 9) Désignation Loher (Tailles hors DIN 42677).

### Zahnradgetriebe

Motorlaterne für IEC-Motoren  
Bauart B3..  
Größen 4 - 18  
mit BIPEX-Kupplung

### Gear Units

Motor Bell Housing for  
IEC Standard Motors  
Type B3.., Sizes 4 - 18  
with BIPEX Coupling

### Réducteurs à engrenages

Lanterne moteur pour  
moteur selon norme IEC  
Type B3.., Tailles 4 - 18  
avec accouplement BIPEX

K20/007

Tabelle / Table / Tableau 8

Größe Size Taille	Motor Moteur IEC 1)	Übersetzungen $i_N$ / Ratios $i_N$ / Rapports $i_N$ 12.5 - 45 (Größen / Sizes / Tailles 4, 5, 7, 9, 11) 16 - 56 (Größen / Sizes / Tailles 6, 8, 10, 12) 12.5 - 45 (Größen / Sizes / Tailles 13, 15, 17) 16 - 56 (Größe / Size / Taille 14) 14 - 50 (Größen / Sizes / Tailles 16, 18)											Übersetzungen $i_N$ / Ratios $i_N$ / Rapports $i_N$ 50 - 71 (Größen / Sizes / Tailles 4, 5, 7, 9, 11) 63 - 90 (Größen / Sizes / Tailles 6, 8, 10, 12) 50 - 71 (Größen / Sizes / Tailles 13, 15, 17) 63 - 90 (Größe / Size / Taille 14) 56 - 80 (Größen / Sizes / Tailles 16, 18)										
		BIPEX BWN	$s_k$ mm	$l_1$ mm	$D_1$ mm	$l_2$ mm	$D_2$ mm	$h_1$ mm	$h_2$ mm	$f$ mm	$f_L$ mm	A mm	BIPEX BWN	$s_k$ mm	$l_1$ mm	$D_1$ mm	$l_2$ mm	$D_2$ mm	$h_1$ mm	$h_2$ mm	$f$ mm	$f_L$ mm	A mm
4	132												72	18	35	25	35	38	10.5	0	646.5	-	250
	160	84	21	40	30	40	42	-3.5	4	708.5	-	250	84	21	40	25	40	42	8.5	0	682.5	-	250
	180	97	24	50	30	50	48	-2.5	2	708.5	-	250	<sup>3)</sup> 97	24	40	25	50	48	11.5	0	682.5	-	250
	200	<sup>3)</sup> 112	27	55	30	60	55	12.5	0	694.5	-	250											
5 / 6	160	84	21	40	35	40	42	14.5	0	771.5	806.5	350	84	21	40	28	40	42	-2.5	3	771.5	806.5	350
	180	97	24	50	35	50	48	17.5	0	771.5	806.5	350	97	24	50	28	50	48	0	2.5	771.5	806.5	350
	200	112	27	60	35	60	55	8.5	0	782.5	818.5	350	112	27	60	28	60	55	-5.5	6	782.5	818.5	350
	225	127	27	65	35	65	60	0	2.5	824.5	859.5	350											
7 / 8	160												84	21	40	35	40	42	0	2.5	903.5	948.5	440
	180												97	24	50	35	50	48	0.5	0	903.5	948.5	440
	200	112	27	60	45	60	55	17.5	0	909.5	954.5	440	112	27	60	35	60	55	0	2.5	909.5	945.5	440
	225	127	27	65	45	65	60	6.5	0	950.5	995.5	440	127	27	65	35	65	60	1.5	0	935.5	980.5	440
	250	127	27	65	45	65	65	5	0	952	997	440	127	27	65	35	65	65	1.5	0	935.5	980.5	440
	280	142	31	75	45	75	75	-5	5	971	1016	440											
9 / 10	200												112	27	60	40	60	55	2.5	0	1034.5	1084.5	440
	225	127	27	65	55	65	60	1.5	0	1075.5	1125.5	440	127	27	65	40	65	60	-4	4.5	1075.5	1125.5	440
	250	127	27	65	55	65	65	0	0	1077	1127	440	127	27	65	40	65	65	-5	5	1077	1127	440
	280	142	31	75	55	75	75	-7.5	7.5	1096	1146	440	142	31	75	40	75	75	2.5	2.5	1076	1126	440
11 / 12	225												127	27	65	50	65	60	-3	3.5	1243.5	1313.5	440
	250	142	31	75	70	75	65	6	0	1260	1330	440	127	27	65	50	65	65	-3	3.5	1243.5	1313.5	440
	280	142	31	75	70	75	75	-6.5	6.5	1279	1349	440	142	31	75	50	75	75	12	0	1229	1299	440
	315 <sup>2)</sup>	162	36	80	70	80	80	-7.5	7.5	1316	1386	440	162	36	80	50	80	80	10	0	1266	1336	440
13 / 14	280												142	31	75	60	75	75	12	0	1424	1494	650
	315 <sup>2)</sup>	182	42	90	80	90	80	-5	4	1511	1581	445	162	36	80	60	80	80	10	0	1461	1531	650
	315 MC <sup>9)</sup>	182	42	90	80	90	80	-5	4	1511	1581	445	182	42	90	60	90	80	16	0	1461	1531	650
	315 MD <sup>9)</sup>	182	42	90	80	90	80	-5	4	1511	1581	445	182	42	90	60	90	80	16	0	1461	1531	650
	315 LB <sup>9)</sup>	202	48	100	80	100	80	-3	0	1511	1581	445	202	48	100	60	100	80	22	0	1461	1531	650
	355 MB <sup>9)</sup>	202	48	100	80	100	90	16	0	1492	1562	650	202	48	100	60	100	90	-4.5	4.5	1492	1562	650
	355 LB <sup>9)</sup>	227	54	110	80	110	90	22	0	1492	1562	650											
15 / 16	315 <sup>2)</sup>												162	36	80	70	80	80	13	0	1700	1746	650
	315 MC <sup>9)</sup>												182	42	90	70	90	80	19	0	1700	1746	650
	315 MD <sup>9)</sup>												182	42	90	70	90	80	19	0	1700	1746	650
	315 LB <sup>9)</sup>	202	48	100	90	100	80	0	0	1750	1796	650	202	48	100	70	100	80	25	0	1700	1746	650
	355 MB <sup>9)</sup>	202	48	100	90	100	90	18	0	1732	1778	650	202	48	100	70	100	90	-3.5	3.5	1732	1778	650
	355 LB <sup>9)</sup>	227	54	110	90	110	90	24	0	1732	1778	650	227	54	110	70	110	90	-1	0	1732	1778	650
17 / 18	315 MC <sup>9)</sup>												182	42	90	80	90	80	-3	0	1945	2005	650
	315 MD <sup>9)</sup>												182	42	90	80	90	80	-3	0	1945	2005	650
	315 LB <sup>9)</sup>												202	48	100	80	100	80	3	0	1945	2005	650
	355 MB <sup>9)</sup>	227	54	110	110	110	90	-5	5	1999	2059	650	202	48	100	80	100	90	1	0	1947	2007	650
	355 LB <sup>9)</sup>	227	54	110	110	110	90	-5	5	1999	2059	650	227	54	110	80	110	90	7	0	1947	2007	650

## Zahnradgetriebe

Motorlaterne für IEC-Motoren  
Bauart B4..  
Größen 5 - 18  
mit BIPEX-Kupplung

## Gear Units

Motor Bell Housing for  
IEC Standard Motors  
Type B4.., Sizes 5 - 18  
with BIPEX Coupling

## Réducteurs à engrenages

Lanterne moteur pour  
moteur selon norme IEC  
Type B4.., Tailles 5 - 18  
avec accouplement BIPEX

K20/007

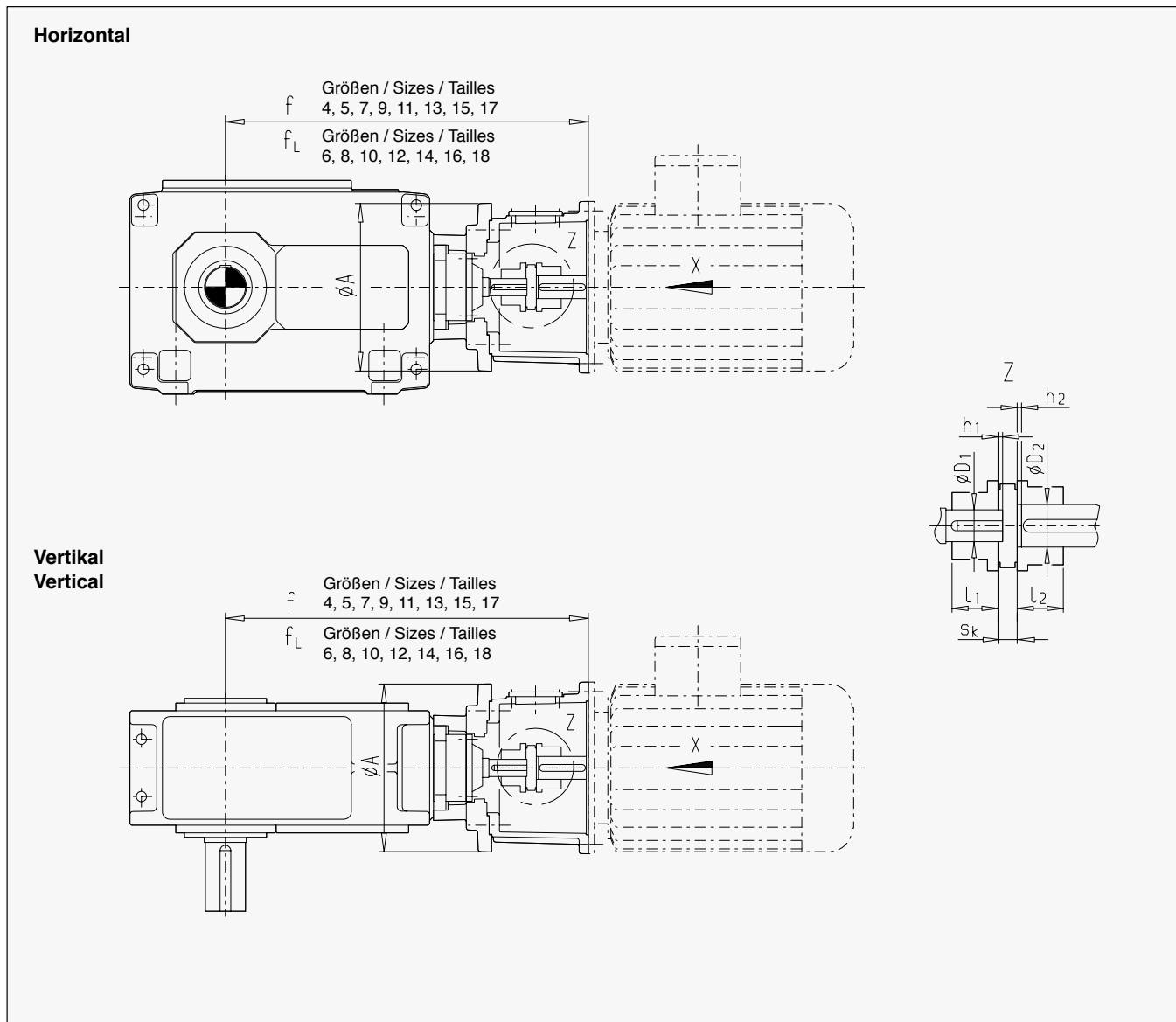

- Bei Anlagen mit besonderen Auslegungsanforderungen (große Schalthäufigkeit, wechselnde Lastrichtung; z.B. Hubwerke, Fahrwerke, ...) ist die Auslegung der Kupplung nach dem jeweils gültigen Kupplungskatalog zu prüfen. Bei abweichenden Kupplungen ist Rücksprache mit Flender notwendig!
- For plants with special design requirements (high switching frequency, alternating direction of load; e.g. hoisting gears, travelling gears, etc.) the coupling design is to be checked in accordance with the respective valid coupling brochure. For other couplings, please consult Flender!
- Pour des installations avec des exigences d'exécution spéciales (cadences élevées, inversion de sens de rotation; par exemple réducteurs de levage ou de translation), la sélection de l'accouplement doit être faite en conformité avec le catalogue accouplements en vigueur. Pour d'autres accouplements, veuillez consulter Flender!
- Anbaumaße für IEC-Normmotoren DIN 42677 (Ansicht X) siehe Seite 161.
- For fitting dimensions for IEC standard motors DIN 42677 (View X), see page 161.
- Cotes de fixation pour moteur selon norme IEC DIN 42677 (Vue X) voir page 161.
- nicht in Verbindung mit Taconite E oder Labyrinth-Abdichtung an der Antriebswelle.
- Not in connection with Taconite E or labyrinth seal on input shaft.
- Exécution pas possible avec joint Taconite E ou labyrinth sur l'arbre d'entrée.

- 1) andere Motorgrößen auf Anfrage
  - 1) Other motor sizes on request
  - 1) Autres tailles sur demande
- 2) nur Baugröße 315 S und 315 M
  - 2) Sizes 315 S and 315 M only
  - 2) Que pour tailles 315 S et 315 M
- 3) Länge  $l_1$  der Kupplungsnahe zum Aufsetzen auf Getriebewelle gekürzt.
  - 3) Length  $l_1$  of coupling hub shortened for fitting onto gear unit shaft.
  - 3) Longueur  $l_1$  du moyeu d'accouplement raccourcie pour montage sur l'arbre du réducteur.
- 9) Loher-Bezeichnung (Baugrößen nicht in DIN 42677 enthalten).
  - 9) Loher designation (Sizes not included in DIN 42677).
  - 9) Désignation Loher (Tailles hors DIN 42677).



### Zahnradgetriebe

Motorlaterne für IEC-Motoren  
Bauart B4..  
Größen 5 - 18  
mit BIPEX-Kupplung

### Gear Units

Motor Bell Housing for  
IEC Standard Motors  
Type B4.., Sizes 5 - 18  
with BIPEX Coupling

### Réducteurs à engrenages

Lanterne moteur pour  
moteur selon norme IEC  
Type B4.., Tailles 5 - 18  
avec accouplement BIPEX

K20/007

Tabelle / Table / Tableau 9

Größe Size Taille	Motor Moteur IEC 1)	Übersetzungen $i_N$ / Ratios $i_N$ / Rappports $i_N$ 80 - 180 (Größen / Sizes / Tailles 5, 7, 9, 11) 100 - 224 (Größen / Sizes / Tailles 6, 8, 10, 12) 80 - 180 (Größen / Sizes / Tailles 13, 15, 17) 100 - 224 (Größe / Size / Taille 14) 90 - 200 (Größen / Sizes / Tailles 16, 18)											Übersetzungen $i_N$ / Ratios $i_N$ / Rappports $i_N$ 200 - 315 (Größen / Sizes / Tailles 5, 7, 9, 11) 250 - 400 (Größen / Sizes / Tailles 6, 8, 10, 12) 200 - 315 (Größen / Sizes / Tailles 13, 15, 17) 250 - 400 (Größe / Size / Taille 14) 224 - 355 (Größen / Sizes / Tailles 16, 18)										
		BIPEX BWN	$s_k$ mm	$l_1$ mm	$D_1$ mm	$l_2$ mm	$D_2$ mm	$h_1$ mm	$h_2$ mm	$f$ mm	$f_L$ mm	A mm	BIPEX BWN	$s_k$ mm	$l_1$ mm	$D_1$ mm	$l_2$ mm	$D_2$ mm	$h_1$ mm	$h_2$ mm	$f$ mm	$f_L$ mm	A mm
5 / 6	100											62	16	30	20	30	28	6	0	735	770	250	
	112	62	16	30	28	30	28	2	2	750	785	250	62	16	30	20	30	28	6	0	735	770	250
	132	72	18	35	28	35	38	0.5	0	767.5	802.5	250	72	18	35	20	35	38	-2.5	2	767.5	802.5	250
	160	84	21	40	28	40	42	-1.5	0	802.5	837.5	250											
7 / 8	112											62	16	30	25	30	28	6	0	855	900	250	
	132	72	18	35	30	35	38	5.5	0	887.5	932.5	250	72	18	35	25	35	38	10.5	0	872.5	917.5	250
	160	84	21	40	30	40	42	-3.5	4	933.5	978.5	250	84	21	40	25	40	42	8.5	0	907.5	952.5	250
	180	97	24	50	30	50	48	-2	2.5	933.5	978.5	250											
	200 <sup>3)</sup>	112	27	55	30	60	55	12.5	0	919.5	964.5	250											
9 / 10	132											72	18	35	28	35	38	-1.5	2	1001.5	1051.5	350	
	160	84	21	40	35	40	42	14.5	0	1036.5	1086.5	350	84	21	40	28	40	42	-2.5	3	1036.5	1086.5	350
	180	97	24	50	35	50	48	17.5	0	1036.5	1086.5	350	97	24	50	28	50	48	0	2.5	1036.5	1086.5	350
	200	112	27	60	35	60	55	8.5	0	1048.5	1098.5	350											
	225	127	27	65	35	65	60	0	2.5	1089.5	1139.5	350											
11 / 12	160											84	21	40	35	40	42	0	2.5	1223.5	1293.5	440	
	180	97	24	50	45	50	48	-2.5	3	1249.5	1319.5	440	97	24	50	35	50	48	0.5	0	1223.5	1293.5	440
	200	112	27	60	45	60	55	17.5	0	1229.5	1299.5	440	112	27	60	35	60	55	-2.5	0	1229.5	1299.5	440
	225	127	27	65	45	65	60	6.5	0	1270.5	1340.5	440	127	27	65	35	65	60	-6.5	7	1270.5	1340.5	440
	250	127	27	65	45	65	65	5	0	1272	1342	440											
	280	142	31	75	45	75	75	-5	5	1291	1361	440											
13 / 14	180											97	24	50	40	50	48	5.5	0	1398.5	1468.5	440	
	200	112	27	60	55	60	55	12.5	0	1404.5	1474.5	440	112	27	60	40	60	55	2.5	0	1404.5	1474.5	440
	225	127	27	65	55	65	60	1.5	0	1445.5	1515.5	440	127	27	65	40	65	60	-4	4.5	1445.5	1515.5	440
	250	127	27	65	55	65	65	0	0	1447	1517	440	127	27	65	40	65	65	-5	5	1447	1517	440
	280	142	31	75	55	75	75	5	0	1446	1516	440	142	31	75	40	75	75	-2.5	2.5	1446	1516	440
	315 <sup>2)</sup>	162	36	80	55	80	80	3	0	1483	1553	440											
	315 MC <sup>9)</sup>	182	42	90	55	90	80	9	0	1483	1553	440											
315 MD <sup>9)</sup>	182	42	90	55	90	80	9	0	1483	1553	440												
15 / 16	200											112	27	60	50	60	55	-5	5.5	1659.5	1705.5	440	
	225	142	31	75	70	75	60	4.5	-3	1700.5	1746.5	440	127	27	65	50	65	60	-3	3.5	1685.5	1731.5	440
	250	142	31	75	70	75	65	6	0	1702	1748	440	127	27	65	50	65	65	-3	3.5	1685.5	1731.5	440
	280	142	31	75	70	75	75	-6.5	6.5	1721	1767	440	142	31	75	50	75	75	12	0	1671	1717	440
	315 <sup>2)</sup>	162	36	80	70	80	80	5	0	1738	1784	440	162	36	80	50	80	80	10	0	1708	1754	440
	315 MC <sup>9)</sup>	182	42	90	70	90	80	11	0	1738	1784	440											
	315 MD <sup>9)</sup>	182	42	90	70	90	80	11	0	1738	1784	440											
	315 LB <sup>9)</sup>	202	48	100	70	100	80	17	0	1738	1784	440											
355 MB <sup>9)</sup>	202	48	100	70	100	90	15	0	1740	1786	650												
17 / 18	225											127	27	65	50	65	60	-3	-3.5	1733.5	1793.5	440	
	250											127	27	65	50	65	65	-3	-3.5	1733.5	1793.5	440	
	280	142	31	75	70	75	75	-6.5	6.5	1769	1829	440	142	31	75	50	75	75	12	0	1718.5	1778.5	440
	315 <sup>2)</sup>	182	42	90	70	90	80	-4.5	4.5	1806	1866	440	162	36	80	50	80	80	10	0	1756	1816	440
	315 MC <sup>9)</sup>	182	42	90	70	90	80	-4.5	4.5	1806	1866	440	182	42	90	70	90	80	16	0	1756	1816	440
	315 MD <sup>9)</sup>	182	42	90	70	90	80	-4.5	4.5	1806	1866	440	182	42	90	70	90	80	16	0	1756	1816	440
	315 LB <sup>9)</sup>	202	48	100	70	100	80	-3	0	1806	1866	440											
	355 MB <sup>9)</sup>	202	48	100	70	100	90	15	0	1788	1848	650											
	355 LB <sup>9)</sup>	227	54	110	70	110	90	21	0	1788	1848	650											

## Zahnradgetriebe

Motorlaterne für IEC-Motoren  
Bauart H2..  
Größen 4 - 14  
mit N-EUPEX-Kupplung

## Gear Units

Motor Bell Housing for  
IEC Standard Motors  
Type H2.., Sizes 4 - 14  
with N-EUPEX Coupling

## Réducteurs à engrenages

Lanterne moteur pour  
moteur selon norme IEC  
Type H2.., Tailles 4 - 14  
avec accouplement N-EUPEX

K20/007

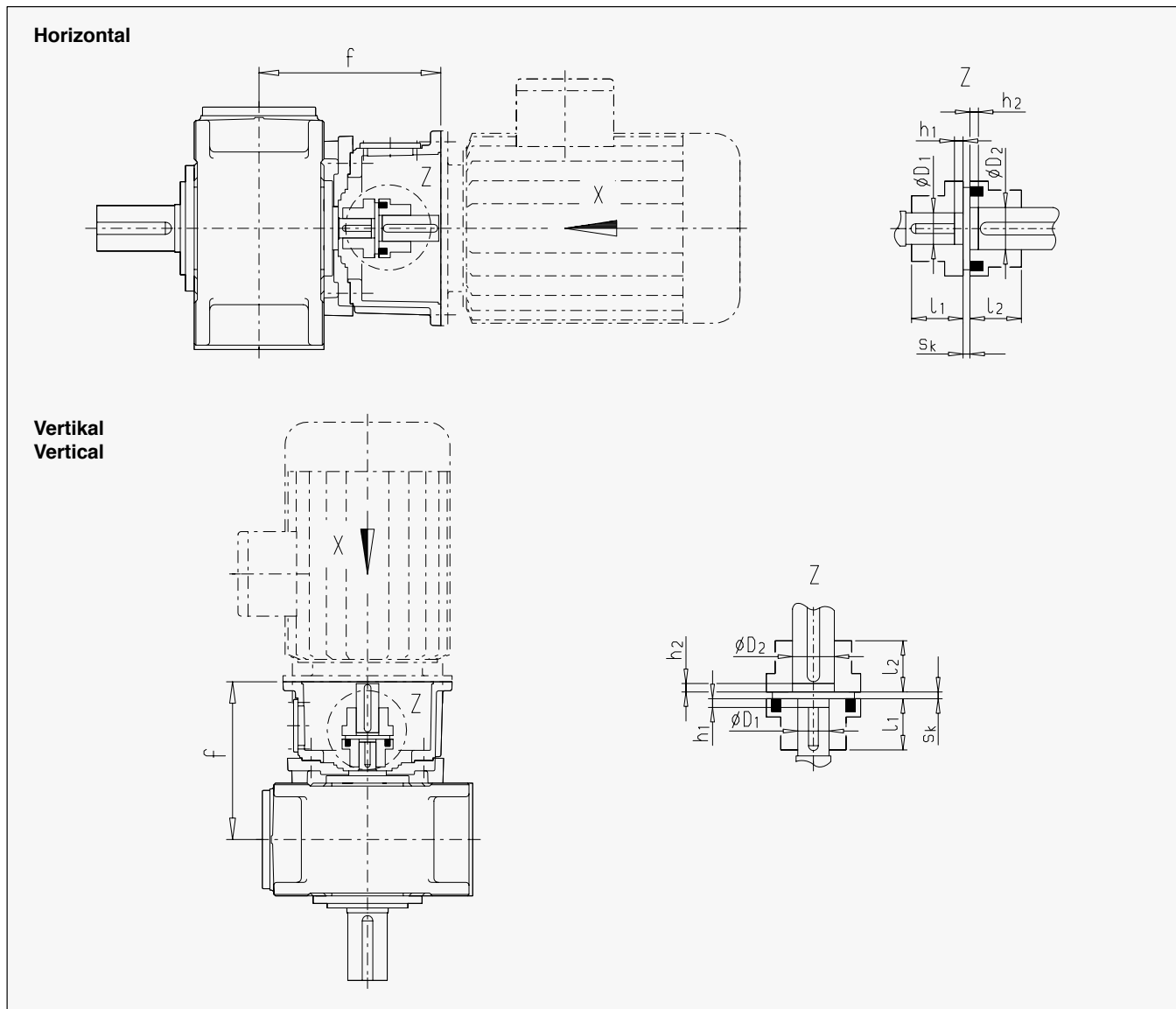

- Bei Anlagen mit besonderen Auslegungsanforderungen (große Schaltfrequenz, wechselnde Lastrichtung; z.B. Hubwerke, Fahrwerke, ...) ist die Auslegung der Kupplung nach dem jeweils gültigen Kupplungskatalog zu prüfen. Bei abweichenden Kupplungen ist Rücksprache mit Flender notwendig!
- For plants with special design requirements (high switching frequency, alternating direction of load; e.g. hoisting gears, travelling gears, etc.) the coupling design is to be checked in accordance with the respective valid coupling brochure. For other couplings, please consult Flender!
- Pour des installations avec des exigences d'exécution spéciales (cadences élevées, inversion de sens de rotation; par exemple réducteurs de levage ou de translation), la sélection de l'accouplement doit être faite en conformité avec le catalogue accouplements en vigueur. Pour d'autres accouplements, veuillez consulter Flender!
- Anbaumaße für IEC-Normmotoren DIN 42677 (Ansicht X) siehe Seite 161.
- For fitting dimensions for IEC standard motors DIN 42677 (View X), see page 161.
- Cotes de fixation pour moteur selon norme IEC DIN 42677 (Vue X) voir page 161.
- Stirnradgetriebe in Ausführung C, D, G, H, I nur auf Anfrage.
- Helical gear unit in C, D, G, H, I design on request only.
- Réducteur cylindrique en exécution C, D, G, H, I seulement sur demande.
- nicht in Verbindung mit Taconite E oder Labyrinth-Abdichtung an der Antriebswelle.
- Not in connection with Taconite E or labyrinth seal on input shaft.
- Exécution pas possible avec joint Taconite E ou labyrinth sur l'arbre d'entrée.

1) andere Motorgrößen auf Anfrage

2) nur Baugröße 315 S und 315 M

4) nur für Vertikalgetriebe

5) Bei Bauart **H2D**. Ausführung A + B; Anbau nicht möglich.

6) Bei Bauart **H2D**. Größe 5 Ausführung A + B; Anbau nicht möglich.

7) Bei Bauart **H2D**. Größe 7 Ausführung A + B; Anbau nicht möglich.

8) Bei Bauart **H2DV** Größe 9 Ausführung A + B; Anbau nicht möglich.

9) Loher-Bezeichnung (Baugrößen nicht in DIN 42677 enthalten).

1) Other motor sizes on request

2) Sizes 315 S and 315 M only

4) For vertical gear units only

5) For type **H2D**. design A + B; fitting not possible.

6) For type **H2D**. size 5 design A + B; fitting not possible.

7) For type **H2D**. size 7 design A + B; fitting not possible.

8) For type **H2DV** size 9 design A + B; fitting not possible.

9) Loher designation (Sizes not included in DIN 42677).

1) Autres tailles sur demande

2) Que pour tailles 315 S et 315 M

4) uniquement pour réducteurs verticaux

5) Pour type **H2D**. exécution A + B; adaptation impossible.

6) Pour type **H2D**. taille 5 exécution A + B; adaptation impossible.

7) Pour type **H2D**. taille 7 exécution A + B; adaptation impossible.

8) Pour type **H2DV** taille 9 exécution A + B; adaptation impossible.

9) Désignation Loher (Tailles hors DIN 42677).

## Zahnradgetriebe

Motorlaterne für IEC-Motoren  
Bauart H2..  
Größen 4 - 14  
mit N-EUPEX-Kupplung

## Gear Units

Motor Bell Housing for  
IEC Standard Motors  
Type H2..., Sizes 4 - 14  
with N-EUPEX Coupling

## Réducteurs à engrenages

Lanterne moteur pour  
moteur selon norme IEC  
Type H2..., Tailles 4 - 14  
avec accouplement N-EUPEX

K20/007

Tabelle / Table / Tableau 10

		Übersetzungen $i_N$ / Ratios $i_N$ / Rapports $i_N$ 6.3 - 11.2 (Größen / Sizes / Tailles 4, 5, 7, 9, 11) 8 - 14 (Größen / Sizes / Tailles 6, 8, 10, 12)										Übersetzungen $i_N$ / Ratios $i_N$ / Rapports $i_N$ 12.5 - 22.4 (Größen / Sizes / Tailles 4, 5, 7, 9, 11) 16 - 28 (Größen / Sizes / Tailles 6, 8, 10, 12)									
Größe Size Taille	Motor Moteur IEC 1)	N- EUPEX	$s_k$ mm	$l_1$ mm	$D_1$ mm	$l_2$ mm	$D_2$ mm	$h_1$ mm	$h_2$ mm	f mm	N- EUPEX	$s_k$ mm	$l_1$ mm	$D_1$ mm	$l_2$ mm	$D_2$ mm	$h_1$ mm	$h_2$ mm	f mm		
4	160 5)										A125	3	50	32	50	42	0	7	370		
	180 5)										A140	3	55	32	55	48	0	7	370		
	200 5)										A160	4	60	32	60	55	0	12	376		
	225 5) 4)	A180	4	70	45	70	60	0	3	417 4)	A180	4	70	32	70	60	0	8	402		
5 / 6	200										A160	4	60	38	60	55	0	13	402		
	225 6)																				
	250 5) 4)	A180	4	70	50	70	65	0	5.5	444.5 4)	A180	4	70	38	70	65	0	9	428		
7 / 8	225										A180	4	70	50	70	60	0	9.5	473.5		
	250 7)										A180	4	70	50	70	65	0	11	475		
	280 7)										A200	4	80	50	80	75	0	10	474		
	315 2) 5) 4)	A225	4	90	60	90	80	0	12	531 4)	A250	5.5	100	50	100	80	0	15.5	511		
9 / 10	280										A200	4	80	60	80	75	0	5	530		
	315 2) 8) 4)	A225	4	90	75	90	80	3	9	566 4)	A225	4	90	60	90	80	0	12	566		
11 / 12	315 2)										A225	4	90	70	90	80	0	17	606		

Tabelle / Table / Tableau 11

		Übersetzungen $i_N$ / Ratios $i_N$ / Rapports $i_N$ 12.5 - 20 (Größe / Size / Taille 13) 16 - 25 (Größe / Size / Taille 14)									
Größe Size Taille	Motor Moteur IEC 1)	N-EUPEX	$s_k$ mm	$l_1$ mm	$D_1$ mm	$l_2$ mm	$D_2$ mm	$h_1$ mm	$h_2$ mm	f mm	
13 / 14	355 MB 9)	4)	A280	5.5	110	85	110	90	1	16.5	693
	355 LB 9)	4)	A280	5.5	110	85	110	90	1	16.5	693

## Zahnradgetriebe

Motorlaterne für IEC-Motoren  
Bauart H3..  
Größen 5 - 18  
mit N-EUPEX-Kupplung

## Gear Units

Motor Bell Housing for  
IEC Standard Motors  
Type H3.., Sizes 5 - 18  
with N-EUPEX Coupling

## Réducteurs à engrenages

Lanterne moteur pour  
moteur selon norme IEC  
Type H3.., Tailles 5 - 18  
avec accouplement N-EUPEX

K20/007

### Horizontal

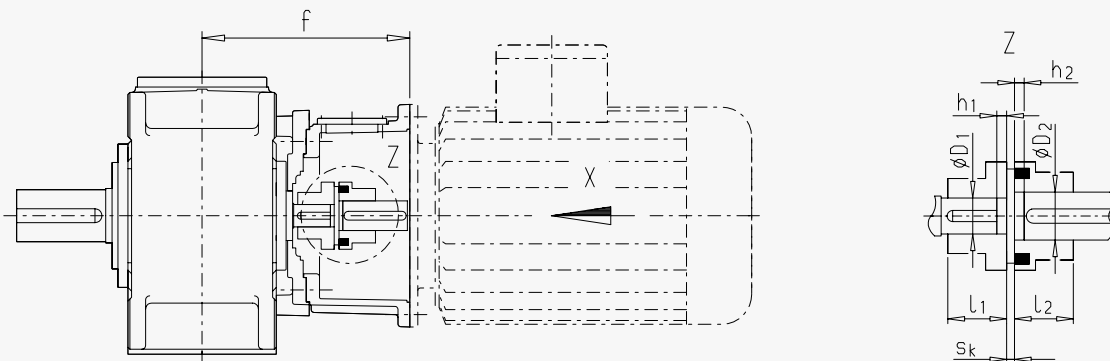

### Vertikal Vertical

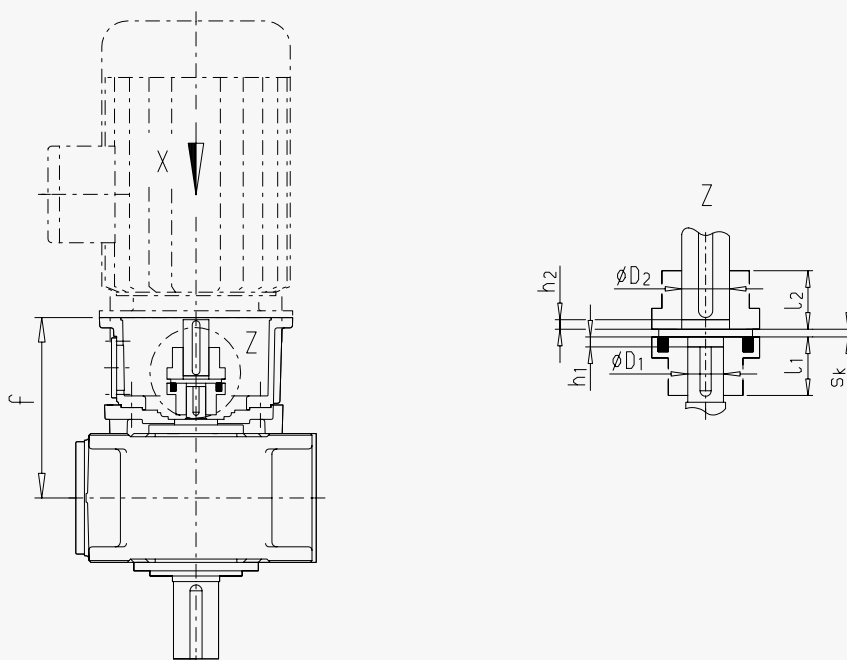

- Bei Anlagen mit besonderen Auslegungsanforderungen (große Schalthäufigkeit, wechselnde Lastrichtung; z.B. Hubwerke, Fahrwerke, ...) ist die Auslegung der Kupplung nach dem jeweils gültigen Kupplungskatalog zu prüfen. Bei abweichenden Kupplungen ist Rücksprache mit Flender notwendig!
- For plants with special design requirements (high switching frequency, alternating direction of load; e.g. hoisting gears, travelling gears, etc.) the coupling design is to be checked in accordance with the respective valid coupling brochure. For other couplings, please consult Flender!
- Pour des installations avec des exigences d'exécution spéciales (cadences élevées, inversion de sens de rotation; par exemple réducteurs de levage ou de translation), la sélection de l'accouplement doit être faite en conformité avec le catalogue accouplements en vigueur. Pour d'autres accouplements, veuillez consulter Flender!
- Anbaumaße für IEC-Normmotoren DIN 42677 (Ansicht X) siehe Seite 161.
- For fitting dimensions for IEC standard motors DIN 42677 (View X), see page 161.
- Cotes de fixation pour moteur selon norme IEC DIN 42677 (Vue X) voir page 161.
- Stirnradgetriebe in Ausführung G, H, I nur auf Anfrage.
- Helical gear unit in G, H, I design on request only.
- Réducteur cylindrique en exécution G, H, I seulement sur demande.
- nicht in Verbindung mit Taconite E oder Labyrinth-Abdichtung an der Antriebswelle.
- Not in connection with Taconite E or labyrinth seal on input shaft.
- Exécution pas possible avec joint Taconite E ou labyrinthe sur l'arbre d'entrée.

- 1) andere Motorgrößen auf Anfrage
- 2) nur Baugröße 315 S und 315 M
- 4) nur für Vertikalgetriebe
- 9) Loher-Bezeichnung (Baugrößen nicht in DIN 42677 enthalten).

- 1) Other motor sizes on request
- 2) Sizes 315 S and 315 M only
- 4) For vertical gear units only
- 9) Loher designation (Sizes not included in DIN 42677).

- 1) Autres tailles sur demande
- 2) Que pour tailles 315 S et 315 M
- 4) uniquement pour réducteurs verticaux
- 9) Désignation Loher (Tailles hors DIN 42677).

## Zahnradgetriebe

Motorlaterne für IEC-Motoren  
Bauart H3..  
Größen 5 - 18  
mit N-EUPEX-Kupplung

## Gear Units

Motor Bell Housing for  
IEC Standard Motors  
Type H3.., Sizes 5 - 18  
with N-EUPEX Coupling

## Réducteurs à engrenages

Lanterne moteur pour  
moteur selon norme IEC  
Type H3.., Tailles 5 - 18  
avec accouplement N-EUPEX

K20/007

Tabelle / Table / Tableau 12

Größe Size Taille	Motor Moteur IEC 1)	Übersetzungen $i_N$ / Ratios $i_N$ / Rappports $i_N$ 25 - 45 (Größen / Sizes / Tailles 5, 7, 9, 11) 31.5 - 56 (Größen / Sizes / Tailles 6, 8, 10, 12) 22.4 - 45 (Größen / Sizes / Tailles 13, 15, 17) 28 - 56 (Größe / Size / Taille 14) 25 - 50 (Größen / Sizes / Tailles 16, 18)										Übersetzungen $i_N$ / Ratios $i_N$ / Rappports $i_N$ 50 - 63 (Größen / Sizes / Tailles 5, 7, 9, 11) 63 - 80 (Größen / Sizes / Tailles 6, 8, 10, 12) 50 - 63 (Größen / Sizes / Tailles 13, 15, 17) 63 - 80 (Größe / Size / Taille 14) 56 - 71 (Größen / Sizes / Tailles 16, 18)										Übersetzungen $i_N$ / Ratios $i_N$ / Rappports $i_N$ 71 - 90 (Größen / Sizes / Tailles 5, 7, 9, 11) 90 - 112 (Größen / Sizes / Tailles 6, 8, 10, 12) 71 - 90 (Größen / Sizes / Tailles 13, 15, 17) 90 - 112 (Größe / Size / Taille 14) 80 - 100 (Größen / Sizes / Tailles 16, 18)									
		N- EUPEX	$s_k$ mm	$l_1$ mm	$D_1$ mm	$l_2$ mm	$D_2$ mm	$h_1$ mm	$h_2$ mm	$f$ mm	N- EUPEX	$s_k$ mm	$l_1$ mm	$D_1$ mm	$l_2$ mm	$D_2$ mm	$h_1$ mm	$h_2$ mm	$f$ mm	N- EUPEX	$s_k$ mm	$l_1$ mm	$D_1$ mm	$l_2$ mm	$D_2$ mm	$h_1$ mm	$h_2$ mm	$f$ mm			
		5 / 6	132																			B95	3	35	24	35	38	7	12	302	
160	A125		3	50	40	50	42	12	9	364	A125	3	50	30	50	42	7	8	338	A125	3	50	24	50	42	17	8	338			
180	A140		3	55	40	55	48	6.5	14.5	364	A140	3	55	30	55	48	5	10	338	A140	3	55	24	55	48	15	10	338			
200	A160		4	60	40	60	55	0	6	350	A160	4	60	30	60	55	17	9	350												
225	A180		4	70	40	70	60	10	7	391																					
250	4) A180		4	70	40	70	65	11.5	5	391																					
7 / 8	160																			A125	3	50	28	50	42	7	12	367			
	180										A140	3	55	35	55	48	0	9	367	A140	3	55	28	55	48	10	9	367			
	200	A160	4	60	45	60	55	0	0	379	A160	4	60	35	60	55	9	12	379	A160	4	60	28	60	55	17	13	379			
	225	A180	4	70	45	70	60	0	11	420	A180	4	70	35	70	60	18	12.5	420												
	250	A180	4	70	45	70	65	0	11	420	A180	4	70	35	70	65	15	16	420												
	280	A200	4	80	45	80	75	14.5	17	440.5																					
9 / 10	180																			A140	3	55	32	55	48	0	8.5	431.5			
	200																			A160	4	60	32	60	55	0	19.5	443.5			
	225	A180	4	70	60	70	60	13.5	7	519.5	A180	4	70	45	70	60	0	10.5	484.5	A180	4	70	32	70	60	9	21.5	484.5			
	250	A180	4	70	60	70	65	11.5	9	519.5	A180	4	70	45	70	65	0	10.5	484.5	A180	4	70	32	70	65	5.5	25	484.5			
	280	A200	4	80	60	80	75	0	6	505	A200	4	80	45	80	75	5	26	505												
	315 2) 4)	A225	4	90	60	90	80	0	13	542	4) A225	4	90	45	90	80	12	26	542												
11 / 12	225																			A180	4	70	42	70	60	9.5	11	489.5			
	250										A180	4	70	65	70	65	0	10.5	489.5	A180	4	70	42	70	65	9.5	11	489.5			
	280	A200	4	80	70	80	75	12	9	540	A200	4	80	75	80	75	14	17	510												
	315 2)	A225	4	90	70	90	80	0	-2	547																					
13 / 14	250																			A180	4	70	50	70	65	5	9.5	578.5			
	280										A200	4	80	60	80	75	0	10	599	A200	4	80	50	80	75	5	30	599			
	315 2)	A225	4	90	85	90	80	18	4	666	A225	4	90	60	90	80	0	17	636												
	315 MC 9)	A225	4	90	85	90	80	18	4	666	A225	4	90	60	90	80	0	17	636												
	315 MD 9)	A225	4	90	85	90	80	18	4	666	A225	4	90	60	90	80	0	17	636												
	315 LB 9)	A225	4	90	85	90	80	18	4	666	A250	4	100	60	100	80	0	17	636												
	355 MB 9)	A280	5.5	110	85	110	90	-2.5	0	643	A280	5.5	110	60	110	90	0	22.5	643												
	355 LB 9)	A280	5.5	110	85	110	90	-2.5	0	643																					
15 / 16	280																			A200	4	80	60	80	75	0	13	647			
	315 2)										A225	4	90	75	90	80	8	12	684	A225	4	90	60	90	80	0	20	684			
	315 MC 9)										A225	4	90	75	90	80	8	12	684	A225	4	90	60	90	80	0	20	684			
	315 MD 9)										A225	4	90	75	90	80	8	12	684	A225	4	90	60	90	80	0	20	684			
	315 LB 9)	A250	4	100	100	100	80	8.5	0	764	A225	4	90	75	90	80	8	12	684	A250	4	100	60	100	80	0	20	684			
	355 MB 9)	A280	5.5	110	100	110	90	17.5	0	743	A280	5.5	110	75	110	90	0	25.5	691	A280	5.5	110	60	110	90	0	25.5	691			
	355 LB 9)	A280	5.5	110	100	110	90	17.5	0	743	A280	5.5	110	75	110	90	0	25.5	691	A280	5.5	110	60	110	90	0	25.5	691			
17 / 18	315 2)																			A225	4	90	60	90	80	0	20	714			
	315 MC 9)																			A225	4	90	60	90	80	0	20	714			
	315 MD 9)																			A225	4	90	60	90	80	0	20	714			
	315 LB 9)										A225	4	90	75	90	80	6.5	13.5	714	A250	4	100	60	100	80	0	20	714			
	355 MB 9)	A280	5.5	110	100	110	90	17.5	0	773	A280	5.5	110	75	110	90	0	25.5	721	A280	5.5	110	60	110	90	0	25.5	721			
	355 LB 9)	A280	5.5	110	100	110	90	17.5	0	773	A280	5.5	110	75	110	90	0	25.5	721	A280	5.5	110	60	110	90	0	25.5	721			

## Zahnradgetriebe

Motorlaterne für IEC-Motoren  
Bauart H4..  
Größen 7 - 18  
mit N-EUPEX-Kupplung

## Gear Units

Motor Bell Housing for  
IEC Standard Motors  
Type H4.., Sizes 7 - 18  
with N-EUPEX Coupling

## Réducteurs à engrenages

Lanterne moteur pour  
moteur selon norme IEC  
Type H4.., Tailles 7 - 18  
avec accouplement N-EUPEX

K20/007

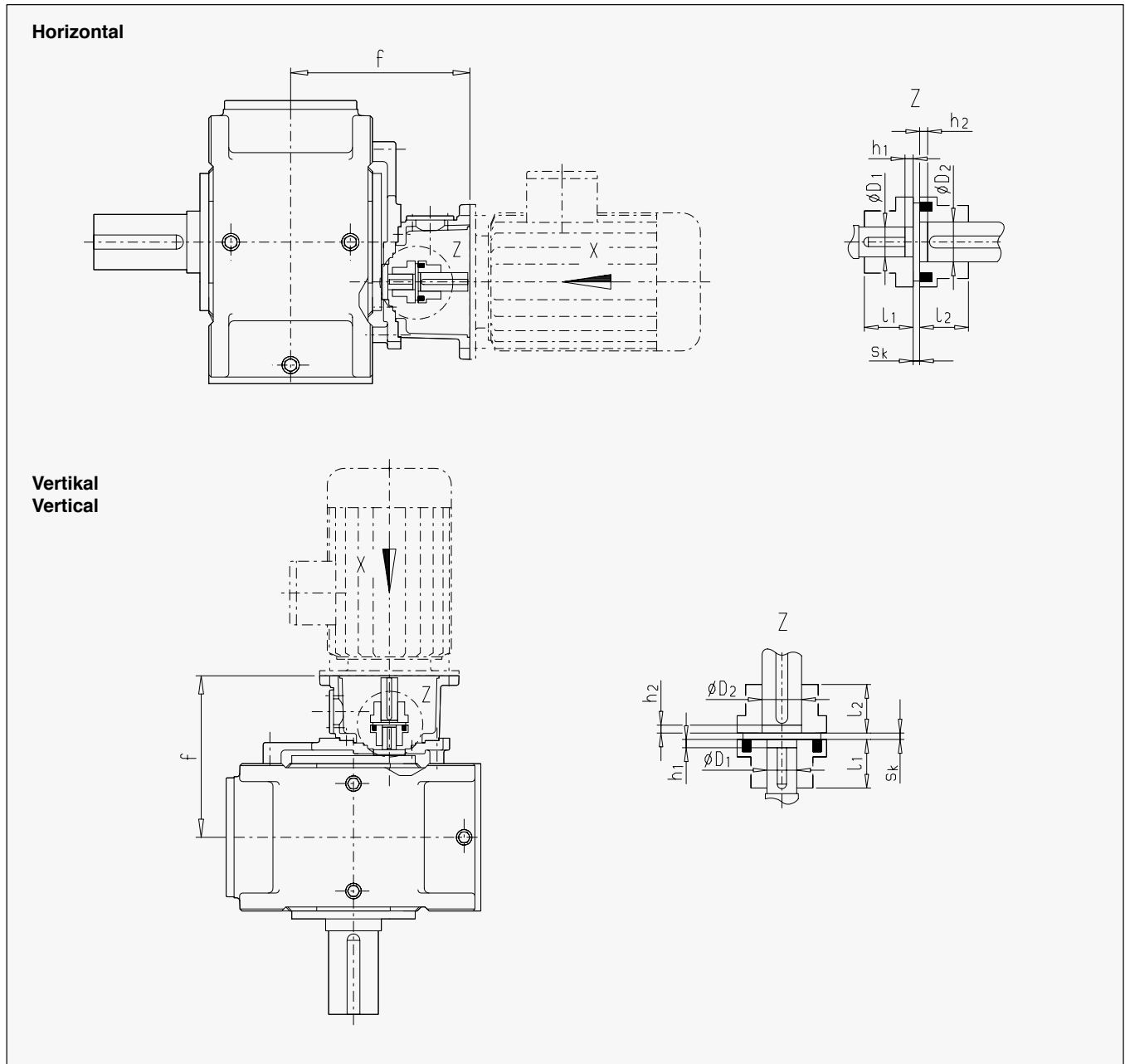

- Bei Anlagen mit besonderen Auslegungsanforderungen (große Schalthäufigkeit, wechselnde Lastrichtung; z.B. Hubwerke, Fahrwerke, ...) ist die Auslegung der Kupplung nach dem jeweils gültigen Kupplungskatalog zu prüfen. Bei abweichenden Kupplungen ist Rücksprache mit Flender notwendig!
- Anbaumaße für IEC-Normmotoren DIN 42677 (Ansicht X) siehe Seite 161.
- Stirnradgetriebe in Ausführung G, H, I nur auf Anfrage.
- nicht in Verbindung mit Taconite E oder Labyrinth-Abdichtung an der Antriebswelle.
- For plants with special design requirements (high switching frequency, alternating direction of load; e.g. hoisting gears, travelling gears, etc.) the coupling design is to be checked in accordance with the respective valid coupling brochure. For other couplings, please consult Flender!
- For fitting dimensions for IEC standard motors DIN 42677 (View X), see page 161.
- Helical gear unit in G, H, I design on request only.
- Not in connection with Taconite E or labyrinth seal on input shaft.
- Pour des installations avec des exigences d'exécution spéciales (cadences élevées, inversion de sens de rotation; par exemple réducteurs de levage ou de translation), la sélection de l'accouplement doit être faite en conformité avec le catalogue accouplements en vigueur. Pour d'autres accouplements, veuillez consulter Flender!
- Cotes de fixation pour moteur selon norme IEC DIN 42677 (Vue X) voir page 161.
- Réducteur cylindrique en exécution G, H, I seulement sur demande.
- Exécution pas possible avec joint Taconite E ou labyrinthe sur l'arbre d'entrée.

- 1) andere Motorgrößen auf Anfrage
- 2) nur Baugröße 315 S und 315 M
- 9) Loher-Bezeichnung (Baugrößen nicht in DIN 42677 enthalten).

- 1) Other motor sizes on request
- 2) Sizes 315 S and 315 M only
- 9) Loher designation (Sizes not included in DIN 42677).

- 1) Autres tailles sur demande
- 2) Que pour tailles 315 S et 315 M
- 9) Désignation Loher (Tailles hors DIN 42677).

## Zahnradgetriebe

Motorlaterne für IEC-Motoren  
Bauart H4..  
Größen 7 - 18  
mit N-EUPEX-Kupplung

## Gear Units

Motor Bell Housing for  
IEC Standard Motors  
Type H4.., Sizes 7 - 18  
with N-EUPEX Coupling

## Réducteurs à engrenages

Lanterne moteur pour  
moteur selon norme IEC  
Type H4.., Tailles 7 - 18  
avec accouplement N-EUPEX

K20/007

Tabelle / Table / Tableau 13

Größe Size Taille	Motor Moteur IEC 1)	Übersetzungen $i_N$ / Ratios $i_N$ / Rapports $i_N$ 100 - 180 (Größen / Sizes / Tailles 7, 9, 11) 125 - 224 (Größen / Sizes / Tailles 8, 10, 12) 100 - 180 (Größen / Sizes / Tailles 13, 15, 17) 125 - 224 (Größe / Size / Taille 14) 112 - 200 (Größen / Sizes / Tailles 16, 18)									Übersetzungen $i_N$ / Ratios $i_N$ / Rapports $i_N$ 200 - 355 (Größen / Sizes / Tailles 7, 9, 11) 250 - 450 (Größen / Sizes / Tailles 8, 10, 12) 200 - 355 (Größen / Sizes / Tailles 13, 15, 17) 250 - 450 (Größe / Size / Taille 14) 224 - 400 (Größen / Sizes / Tailles 16, 18)								
		N- EUPEX	$s_k$ mm	$l_1$ mm	$D_1$ mm	$l_2$ mm	$D_2$ mm	$h_1$ mm	$h_2$ mm	f mm	N- EUPEX	$s_k$ mm	$l_1$ mm	$D_1$ mm	$l_2$ mm	$D_2$ mm	$h_1$ mm	$h_2$ mm	f mm
7 / 8	100										B80	3	30	24	30	28	7	6	296
	112										B80	3	30	24	30	28	7	6	296
	132	B95	3	35	30	35	38	7	8	328.5									
	160	A125	3	50	30	50	42	6.5	15	364.5	A125	3	50	24	50	42	16.5	15	364.5
	180	A140	3	55	30	55	48	17	4.5	364.5									
9 / 10	132										B95	3	35	28	35	38	10	11.5	369.5
	160	A125	3	50	35	50	42	6.5	11	405.5	A125	3	50	28	50	42	13	14.5	405.5
	180	A140	3	55	35	55	48	10	7.5	405.5	A140	3	55	28	55	48	20	7.5	405.5
	200	A160	4	60	35	60	55	10	14.5	417.5									
	225	A180	4	70	35	70	60	18.5	21	458.5									
11 / 12	160										A125	3	50	32	50	42	0	4.5	447.5
	180	A140	3	55	45	55	48	7	3.5	437.5	A140	3	55	32	55	48	0	4.5	447.5
	200	A160	4	60	45	60	55	6.5	15	485.5	A160	4	60	32	60	55	0	15.5	459.5
	225	A180	4	70	45	70	60	0	6.5	500.5	A180	4	70	32	70	60	3	23.5	500.5
	250	A180	4	70	45	70	65	0	6.5	500.5									
13 / 14	160										A125	3	50	38	50	42	9	10.5	517.5
	180										A140	3	55	38	55	48	3.5	16	517.5
	200	A160	4	60	50	60	55	2	8.5	529.5	A160	4	60	38	60	55	0	4.5	503.5
	225	A180	4	70	50	70	60	9.5	21	579.5	A180	4	70	38	70	60	4	11.5	544.5
	250	A180	4	70	50	70	65	7.5	23	579.5	A180	4	70	38	70	65	4	11.5	544.5
	280	A200	4	80	50	80	75	0	16	565									
	315 2)																		
15 / 16	200										A160	4	60	50	60	55	0	3.5	572.5
	225	A180	4	70	60	70	60	15.5	9	648.5	A180	4	70	50	70	60	0	14.5	613.5
	250	A180	4	70	60	70	65	13.5	11	648.5	A180	4	70	50	70	65	0	14.5	613.5
	280	A200	4	80	60	80	75	0	10	634	A200	4	80	50	80	75	3	32	634
	315 2)	A225	4	90	60	90	80	0	17	671									
	315 MC 9)	A225	4	90	60	90	80	0	17	671									
	315 MD 9)	A225	4	90	60	90	80	0	17	671									
	315 LB 9)	A225	4	90	60	90	80	0	17	671									
17 / 18	225										A180	4	70	50	70	60	3	16.5	623.5
	250										A180	4	70	50	70	65	4	15.5	623.5
	280	A200	4	80	60	80	75	5	10	644	A200	4	80	50	80	75	6	34	644
	315 2)	A225	4	90	60	90	80	0	22	681									
	315 MC 9)	A225	4	90	60	90	80	0	22	681									
	315 MD 9)	A225	4	90	60	90	80	0	22	681									
	315 LB 9)	A225	4	90	60	90	80	0	22	681									
	355 MB 9)																		

## Zahnradgetriebe

Motorlaterne für IEC-Motoren  
Bauart B2..  
Größen 4 - 14  
mit N-EUPEX-Kupplung

## Gear Units

Motor Bell Housing for  
IEC Standard Motors  
Type B2.., Sizes 4 - 14  
with N-EUPEX Coupling

## Réducteurs à engrenages

Lanterne moteur pour  
moteur selon norme IEC  
Type B2.., Tailles 4 - 14  
avec accouplement N-EUPEX

K20/007

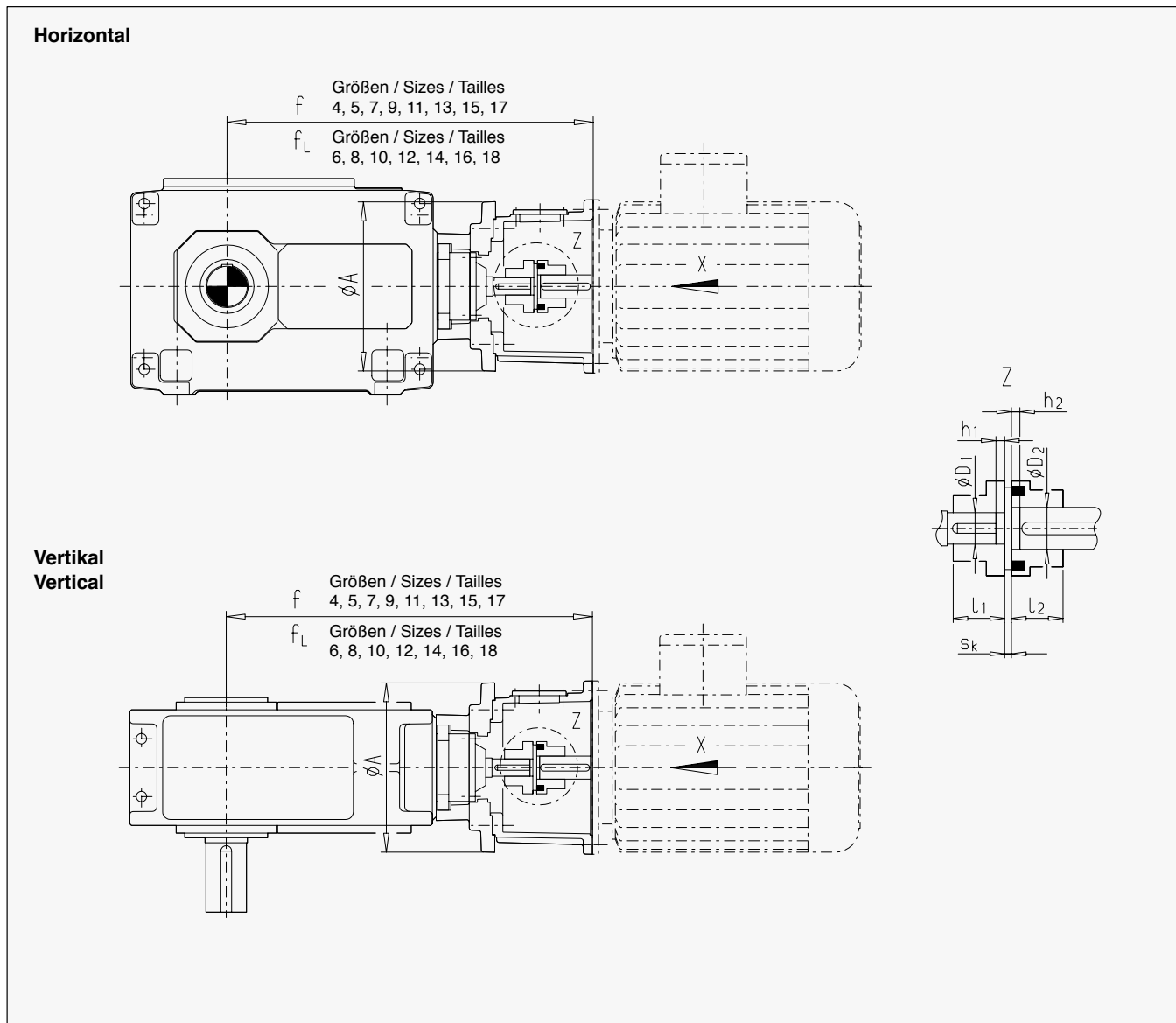

- Bei Anlagen mit besonderen Auslegungsanforderungen (große Schalthäufigkeit, wechselnde Lastrichtung; z.B. Hubwerke, Fahrwerke, ...) ist die Auslegung der Kupplung nach dem jeweils gültigen Kupplungskatalog zu prüfen. Bei abweichenden Kupplungen ist Rücksprache mit Flender notwendig!
- For plants with special design requirements (high switching frequency, alternating direction of load; e.g. hoisting gears, travelling gears, etc.) the coupling design is to be checked in accordance with the respective valid coupling brochure. For other couplings, please consult Flender!
- Pour des installations avec des exigences d'exécution spéciales (cadences élevées, inversion de sens de rotation; par exemple réducteurs de levage ou de translation), la sélection de l'accouplement doit être faite en conformité avec le catalogue accouplements en vigueur. Pour d'autres accouplements, veuillez consulter Flender!
- Anbaumaße für IEC-Normmotoren DIN 42677 (Ansicht X) siehe Seite 161.
- For fitting dimensions for IEC standard motors DIN 42677 (View X), see page 161.
- Cotes de fixation pour moteur selon norme IEC DIN 42677 (Vue X) voir page 161.
- nicht in Verbindung mit Taconite E oder Labyrinth-Abdichtung an der Antriebswelle.
- Not in connection with Taconite E or labyrinth seal on input shaft.
- Exécution pas possible avec joint Taconite E ou labyrinth sur l'arbre d'entrée.

1) andere Motorgrößen auf Anfrage

2) nur Baugröße 315 S und 315 M

9) Loher-Bezeichnung

(Baugrößen nicht in DIN 42677 enthalten).

1) Other motor sizes on request

2) Sizes 315 S and 315 M only

9) Loher designation

(Sizes not included in DIN 42677).

1) Autres tailles sur demande

2) Que pour tailles 315 S et 315 M

9) Désignation Loher

(Tailles hors DIN 42677).



## Zahnradgetriebe

Motorlaterne für IEC-Motoren  
 Bauart B2..  
 Größen 4 - 14  
 mit N-EUPEX-Kupplung

## Gear Units

Motor Bell Housing for  
 IEC Standard Motors  
 Type B2.., Sizes 4 - 14  
 with N-EUPEX Coupling

## Réducteurs à engrenages

Lanterne moteur pour  
 moteur selon norme IEC  
 Type B2.., Tailles 4 - 14  
 avec accouplement N-EUPEX

K20/007

Tabelle / Table / Tableau 14

		Übersetzungen $i_N$ / Ratios $i_N$ / Rapports $i_N$ 5 - 11.2 (Größen / Sizes / Tailles 4, 5, 7, 9, 11) 6.3 - 14 (Größen / Sizes / Tailles 6, 8, 10, 12) 12.5 - 18 (Größe / Size / Taille 13) 16 - 22.4 (Größe / Size / Taille 14)											
Größe Size Taille	Motor Moteur IEC 1)	N-EUPEX	$s_k$ mm	$l_1$ mm	$D_1$ mm	$l_2$ mm	$D_2$ mm	$h_1$ mm	$h_2$ mm	f mm	$f_L$ mm	A mm	
4	180												
	200	A160	4	60	45	60	55	0	5.5	684.5	-	400	
5 / 6	200												
	225												
7 / 8	250												
	280	A200	4	80	70	80	75	9	6	934	979	550	
9 / 10	280												
11 / 12	315 2)												
13 / 14	355 MB 9)	Auf Anfrage / On request / Sur demande											
	355 LB 9)												

## Zahnradgetriebe

Motorlaterne für IEC-Motoren  
Bauart B3..  
Größen 4 - 18  
mit N-EUPEX-Kupplung

## Gear Units

Motor Bell Housing for  
IEC Standard Motors  
Type B3.., Sizes 4 - 18  
with N-EUPEX Coupling

## Réducteurs à engrenages

Lanterne moteur pour  
moteur selon norme IEC  
Type B3.., Tailles 4 - 18  
avec accouplement N-EUPEX

K20/007

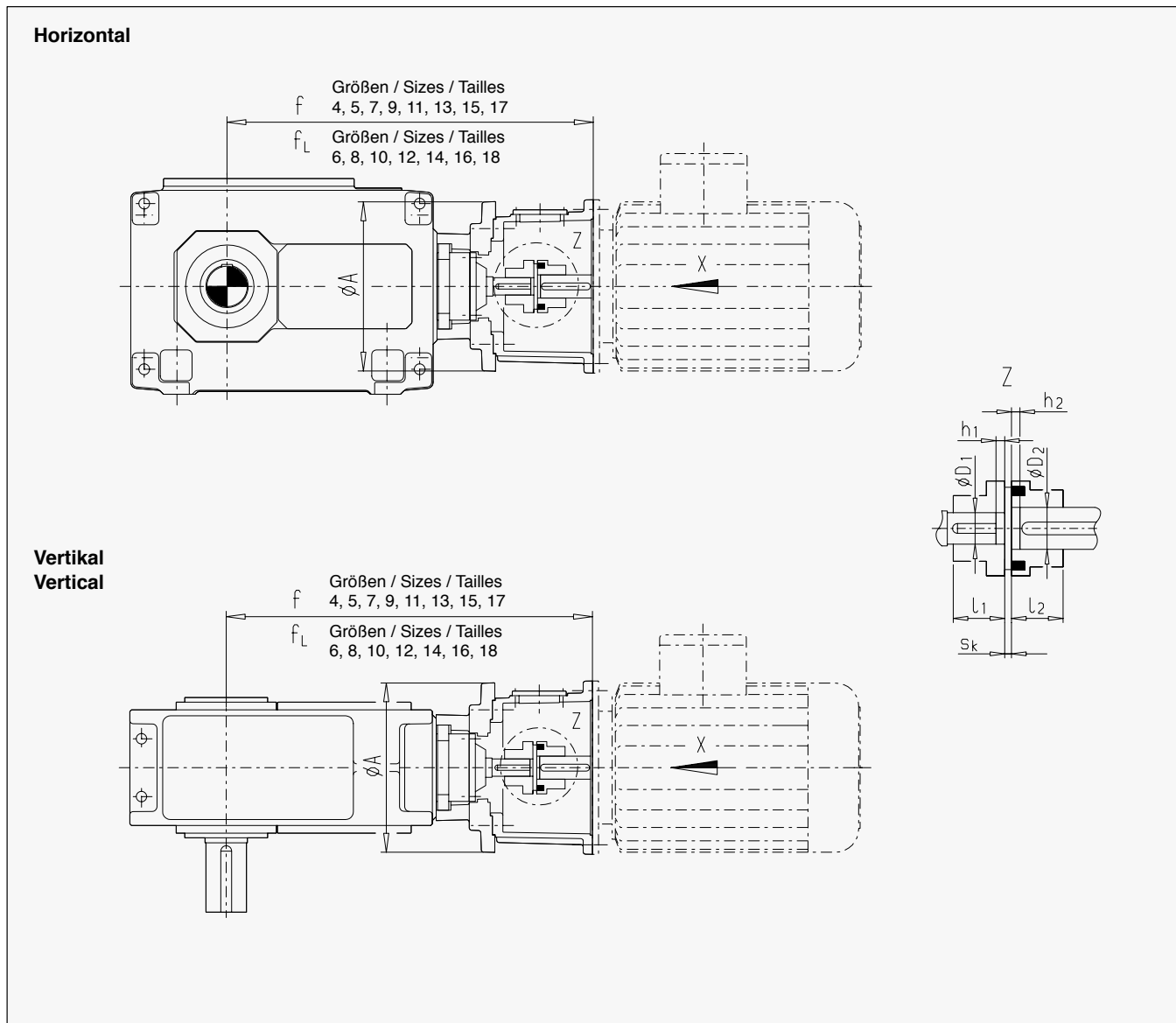

- Bei Anlagen mit besonderen Auslegungsanforderungen (große Schalthäufigkeit, wechselnde Lastrichtung; z.B. Hubwerke, Fahrwerke, ...) ist die Auslegung der Kupplung nach dem jeweils gültigen Kupplungskatalog zu prüfen. Bei abweichenden Kupplungen ist Rücksprache mit Flender notwendig!
- For plants with special design requirements (high switching frequency, alternating direction of load; e.g. hoisting gears, travelling gears, etc.) the coupling design is to be checked in accordance with the respective valid coupling brochure. For other couplings, please consult Flender!
- Pour des installations avec des exigences d'exécution spéciales (cadences élevées, inversion de sens de rotation; par exemple réducteurs de levage ou de translation), la sélection de l'accouplement doit être faite en conformité avec le catalogue accouplements en vigueur. Pour d'autres accouplements, veuillez consulter Flender!
- Anbaumaße für IEC-Normmotoren DIN 42677 (Ansicht X) siehe Seite 161.
- For fitting dimensions for IEC standard motors DIN 42677 (View X), see page 161.
- Cotes de fixation pour moteur selon norme IEC DIN 42677 (Vue X) voir page 161.
- nicht in Verbindung mit Taconite E oder Labyrinth-Abdichtung an der Antriebswelle.
- Not in connection with Taconite E or labyrinth seal on input shaft.
- Exécution pas possible avec joint Taconite E ou labyrinth sur l'arbre d'entrée.

1) andere Motorgrößen auf Anfrage

2) nur Baugröße 315 S und 315 M

9) Loher-Bezeichnung

(Baugrößen nicht in DIN 42677 enthalten).

1) Other motor sizes on request

2) Sizes 315 S and 315 M only

9) Loher designation

(Sizes not included in DIN 42677).

1) Autres tailles sur demande

2) Que pour tailles 315 S et 315 M

9) Désignation Loher

(Tailles hors DIN 42677).

### Zahnradgetriebe

Motorlaterne für IEC-Motoren  
Bauart B3..  
Größen 4 - 18  
mit N-EUPEX-Kupplung

### Gear Units

Motor Bell Housing for  
IEC Standard Motors  
Type B3.., Sizes 4 - 18  
with N-EUPEX Coupling

### Réducteurs à engrenages

Lanterne moteur pour  
moteur selon norme IEC  
Type B3.., Tailles 4 - 18  
avec accouplement N-EUPEX

K20/007

Tabelle / Table / Tableau 15

Größe Size Taille	Motor Moteur IEC 1)	Übersetzungen $i_N$ / Ratios $i_N$ / Rapports $i_N$ 12.5 - 45 (Größen / Sizes / Tailles 3, 4, 5, 7, 9, 11) 16 - 56 (Größen / Sizes / Tailles 6, 8, 10, 12) 12.5 - 45 (Größen / Sizes / Tailles 13, 15, 17) 16 - 56 (Größe / Size / Taille 14) 14 - 50 (Größen / Sizes / Tailles 16, 18)											Übersetzungen $i_N$ / Ratios $i_N$ / Rapports $i_N$ 50 - 71 (Größen / Sizes / Tailles 3, 4, 5, 7, 9, 11) 63 - 90 (Größen / Sizes / Tailles 6, 8, 10, 12) 50 - 71 (Größen / Sizes / Tailles 13, 15, 17) 63 - 90 (Größe / Size / Taille 14) 56 - 80 (Größen / Sizes / Tailles 16, 18)										
		N- EUPEX	$s_k$ mm	$l_1$ mm	$D_1$ mm	$l_2$ mm	$D_2$ mm	$h_1$ mm	$h_2$ mm	f mm	$f_L$ mm	A mm	N- EUPEX	$s_k$ mm	$l_1$ mm	$D_1$ mm	$l_2$ mm	$D_2$ mm	$h_1$ mm	$h_2$ mm	f mm	$f_L$ mm	A mm
4	132												B95	3	35	25	35	38	0	4.5	646.5	-	250
	160	A125	3	50	30	50	42	0	-0.5	682.5	-	250	A125	3	50	25	50	42	0	9.5	682.5	-	250
	180	A140	3	55	30	55	48	0	-0.5	682.5	-	250	A140	3	55	25	55	48	0	9.5	682.5	-	250
	200	A160	4	60	30	60	55	0	10.5	694.5	-	250											
5 / 6	160	A125	3	50	35	50	42	0	3.5	771.5	806.5	340	A125	3	50	28	50	42	7	16.5	771.5	806.5	340
	180	A140	3	55	35	55	48	0	3.5	771.5	806.5	340	A140	3	55	28	55	48	2	21.5	771.5	806.5	340
	200	A160	4	60	35	60	55	0	14.5	783.5	818.5	340	A160	4	60	28	60	55	7.5	27	783.5	818.5	340
	225	A180	4	70	35	70	60	7.5	18	824.5	859.5	340											
7 / 8	160												A125	3	50	35	50	42	8	12.5	903.5	948.5	440
	180												A140	3	55	35	55	48	3	17.5	903.5	948.5	440
	200	A160	4	60	45	60	55	0	5.5	909.5	954.5	440	A160	4	60	35	60	55	0	1.5	885.5	930.5	440
	225	A180	4	70	45	70	60	0	1.5	935.5	980.5	440	A180	4	70	35	70	60	0	21.5	935.5	980.5	440
	250	A180	4	70	45	70	65	0	1.5	935.5	980.5	440	A180	4	70	35	70	65	0	21.5	935.5	980.5	440
	280	A200	4	80	45	80	75	0	17	950.5	945.5	440											
9 / 10	200												A160	4	60	40	60	55	0	20.5	1034.5	1084.5	440
	225	A180	4	70	55	70	60	1.5	5	1060.5	1110.5	440	A180	4	70	40	70	60	0	16.5	1060.5	1110.5	440
	250	A180	4	70	55	70	65	0	6.5	1060.5	1110.5	440	A180	4	70	40	70	65	0	16.5	1060.5	1110.5	440
	280	A200	4	80	55	80	75	0	22	1046	1096.5	440	A200	4	80	40	80	75	0	2	1046	1096	440
11 / 12	225												A180	4	70	50	70	60	9	20.5	1243.5	1313.5	440
	250	A180	4	70	70	70	65	4.5	0	1243.5	1313.5	440	A180	4	70	50	70	65	9	20.5	1243.5	1313.5	440
	280	A200	4	80	70	80	75	12	8	1258.5	1328.5	440	A200	4	80	50	80	75	0	15	1229	1299	440
	315 <sup>2)</sup>	A225	4	90	70	90	80	10	17	1296	1366	440	A225	4	90	50	90	80	0	22	1266	1336	440
13 / 14	280												A200	4	80	60	80	75	0	15	1424	1494	445
	315 <sup>2)</sup>	A225	4	90	80	90	80	9	8	1481	1551	445	A225	4	90	60	90	80	0	22	1461	1531	445
	315 MC <sup>9)</sup>	A225	4	90	80	90	80	9	8	1481	1551	445	A225	4	90	60	90	80	0	22	1461	1531	445
	315 MD <sup>9)</sup>	A225	4	90	80	90	80	9	8	1481	1551	445	A225	4	90	60	90	80	0	22	1461	1531	445
	315 LB <sup>9)</sup>	A225	4	90	80	90	80	9	8	1481	1551	445	A225	4	90	60	90	80	0	22	1461	1531	445
	355 MB <sup>9)</sup>	A315	5	125	80	125	90	0	2	1467	1537	645	A315	5	125	60	125	90	0	27	1467	1537	645
	355 LB <sup>9)</sup>	A315	5	125	80	125	90	0	2	1467	1537	645											
15 / 16	315 <sup>2)</sup>												A225	4	90	70	90	80	3	14	1698	1744	520
	315 MC <sup>9)</sup>												A225	4	90	70	90	80	3	14	1698	1744	520
	315 MD <sup>9)</sup>												A225	4	90	70	90	80	3	14	1698	1744	520
	315 LB <sup>9)</sup>	A250	5	100	90	100	80	21	0	1728	1774	520	A250	4	100	70	100	80	3	14	1698	1744	520
	355 MB <sup>9)</sup>	A315	5	125	90	125	90	0	0	1707	1753	645	A315	5	125	70	125	90	5	20	1707	1753	645
	355 LB <sup>9)</sup>	A315	5	125	90	125	90	0	0	1707	1753	645	A315	5	125	70	125	90	5	20	1707	1753	645
17 / 18	315 MC <sup>2)</sup>												A225	4	90	80	90	80	10	1	1945	2000.5	645
	315 MD <sup>9)</sup>												A225	4	90	80	90	80	10	1	1945	2000.5	645
	315 LB <sup>9)</sup>												A250	4	100	80	100	80	10	1	1945	2000.5	645
	355 MB <sup>9)</sup>	A315	5	125	110	125	90	7	0	1947	2007	645	A315	5	125	80	125	90	0	17	1922	1982	645
	355 LB <sup>9)</sup>	A315	5	125	110	125	90	7	0	1947	2007	645	A315	5	125	80	125	90	0	17	1922	1982	645

## Zahnradgetriebe

Motorlaterne für IEC-Motoren  
Bauart B4..  
Größen 5 - 18  
mit N-EUPEX-Kupplung

## Gear Units

Motor Bell Housing for  
IEC Standard Motors  
Type B4.., Sizes 5 - 18  
with N-EUPEX Coupling

## Réducteurs à engrenages

Lanterne moteur pour  
moteur selon norme IEC  
Type B4.., Tailles 5 - 18  
avec accouplement N-EUPEX

K20/007

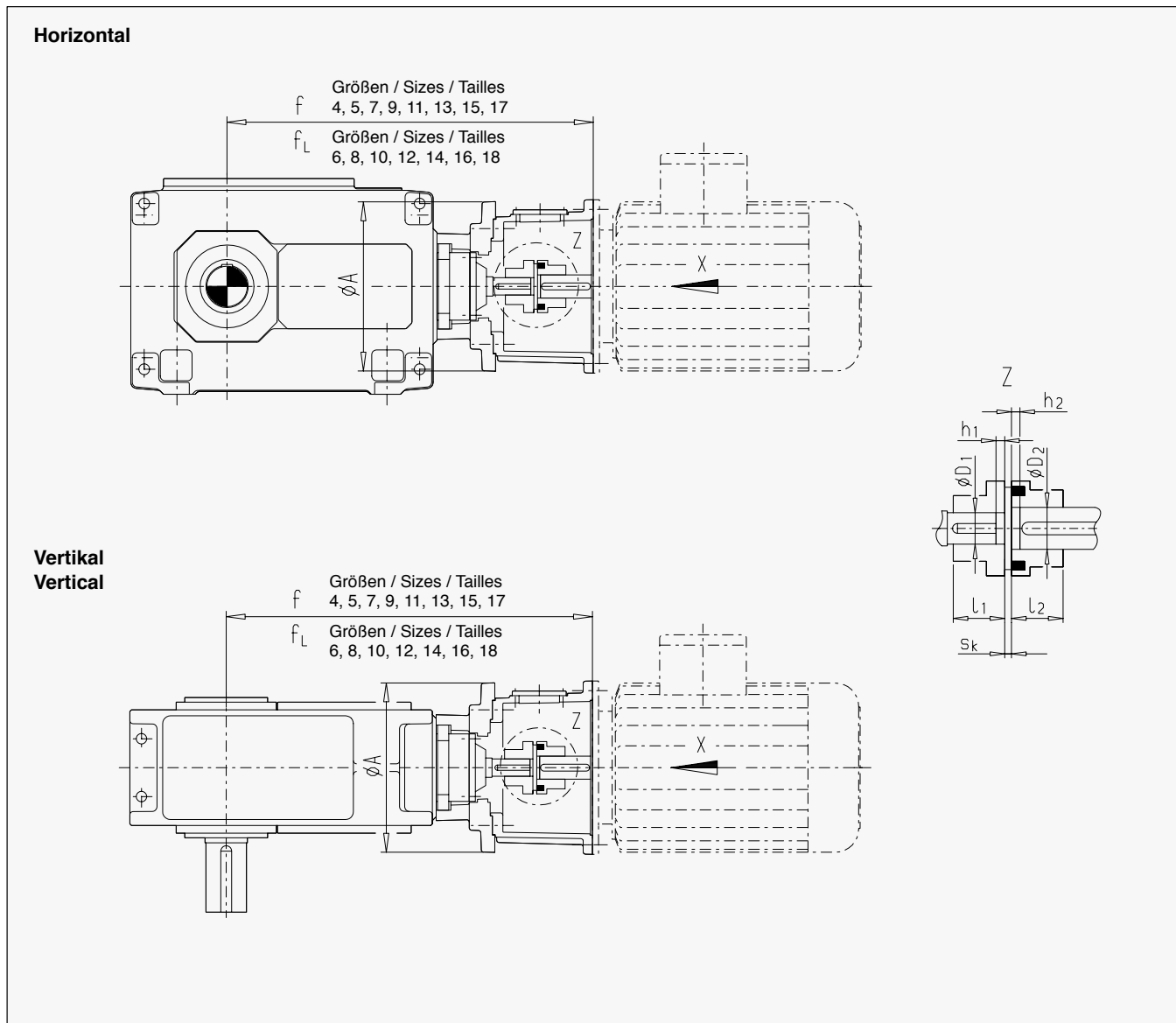

- Bei Anlagen mit besonderen Auslegungsanforderungen (große Schalthäufigkeit, wechselnde Lastrichtung; z.B. Hubwerke, Fahrwerke, ...) ist die Auslegung der Kupplung nach dem jeweils gültigen Kupplungskatalog zu prüfen. Bei abweichenden Kupplungen ist Rücksprache mit Flender notwendig!
- For plants with special design requirements (high switching frequency, alternating direction of load; e.g. hoisting gears, travelling gears, etc.) the coupling design is to be checked in accordance with the respective valid coupling brochure. For other couplings, please consult Flender!
- Pour des installations avec des exigences d'exécution spéciales (cadences élevées, inversion de sens de rotation; par exemple réducteurs de levage ou de translation), la sélection de l'accouplement doit être faite en conformité avec le catalogue accouplements en vigueur. Pour d'autres accouplements, veuillez consulter Flender!
- Anbaumaße für IEC-Normmotoren DIN 42677 (Ansicht X) siehe Seite 161.
- For fitting dimensions for IEC standard motors DIN 42677 (View X), see page 161.
- Cotes de fixation pour moteur selon norme IEC DIN 42677 (Vue X) voir page 161.
- nicht in Verbindung mit Taconite E oder Labyrinth-Abdichtung an der Antriebswelle.
- Not in connection with Taconite E or labyrinth seal on input shaft.
- Exécution pas possible avec joint Taconite E ou labyrinth sur l'arbre d'entrée.

1) andere Motorgrößen auf Anfrage

2) nur Baugröße 315 S und 315 M

9) Loher-Bezeichnung

(Baugrößen nicht in DIN 42677 enthalten).

1) Other motor sizes on request

2) Sizes 315 S and 315 M only

9) Loher designation

(Sizes not included in DIN 42677).

1) Autres tailles sur demande

2) Que pour tailles 315 S et 315 M

9) Désignation Loher

(Tailles hors DIN 42677).

### Zahnradgetriebe

Motorlaterne für IEC-Motoren  
Bauart B4..  
Größen 5 - 18  
mit N-EUPEX-Kupplung

### Gear Units

Motor Bell Housing for  
IEC Standard Motors  
Type B4.., Sizes 5 - 18  
with N-EUPEX Coupling

### Réducteurs à engrenages

Lanterne moteur pour  
moteur selon norme IEC  
Type B4.., Tailles 5 - 18  
avec accouplement N-EUPEX

K20/007

Tabelle / Table / Tableau 16

Größe Size Taille	Motor Moteur IEC 1)	Übersetzungen $i_N$ / Ratios $i_N$ / Rapports $i_N$ 80 - 180 (Größen / Sizes / Tailles 5, 7, 9, 11) 100 - 224 (Größen / Sizes / Tailles 6, 8, 10, 12) 80 - 180 (Größen / Sizes / Tailles 13, 15, 17) 100 - 224 (Größe / Size / Taille 14) 90 - 200 (Größen / Sizes / Tailles 16, 18)											Übersetzungen $i_N$ / Ratios $i_N$ / Rapports $i_N$ 200 - 315 (Größen / Sizes / Tailles 5, 7, 9, 11) 250 - 400 (Größen / Sizes / Tailles 6, 8, 10, 12) 200 - 315 (Größen / Sizes / Tailles 13, 15, 17) 250 - 400 (Größe / Size / Taille 14) 224 - 355 (Größen / Sizes / Tailles 16, 18)											
		N- EUPEX	s <sub>k</sub> mm	l <sub>1</sub> mm	D <sub>1</sub> mm	l <sub>2</sub> mm	D <sub>2</sub> mm	h <sub>1</sub> mm	h <sub>2</sub> mm	f mm	f <sub>L</sub> mm	A mm	N- EUPEX	s <sub>k</sub> mm	l <sub>1</sub> mm	D <sub>1</sub> mm	l <sub>2</sub> mm	D <sub>2</sub> mm	h <sub>1</sub> mm	h <sub>2</sub> mm	f mm	f <sub>L</sub> mm	A mm	
5 / 6	100												B80	3	30	20	30	28	0	6	734	769	245	
	112	B80	3	30	28	30	28	0	1	734	769	245	B80	3	30	20	30	28	0	6	734	769	245	
	132	B95	3	35	28	35	38	5.5	8	766.5	801.5	245	B95	3	35	20	35	38	6	12.5	766.5	801.5	245	
	160	A125	3	50	28	50	42	4.5	15	802.5	837.5	245												
7 / 8	112												B80	3	30	25	30	28	3.5	2.5	854	899	250	
	132	B95	3	35	30	35	38	3	5.5	886.5	931.5	250	B95	3	35	25	35	38	0	3.5	871.5	916.5	250	
	160	A125	3	50	30	50	42	0	-0.5	907.5	952.5	250	A125	3	50	25	50	42	0	9.5	907.5	952.5	250	
	180	A140	3	55	30	55	48	0	-0.5	907.5	952.5	250												
	200	A160	4	60	30	60	55	0	10.5	919.5	964.5	250												
9 / 10	132												B95	3	35	28	35	38	7.5	10	1000.5	1050.5	340	
	160	A125	3	50	35	50	42	0	3.5	1036.5	1086.5	340	A125	3	50	28	50	42	7	16.5	1036.5	1086.5	340	
	180	A140	3	55	35	55	48	0	3.5	1036.5	1086.5	340	A140	3	55	28	55	48	2	21.5	1036.5	1086.5	340	
	200	A160	4	60	35	60	55	0	14.5	1048.5	1098.5	340												
	225	A180	4	70	35	70	60	0	25.5	1089.5	1139.5	340												
11 / 12	160												A125	3	50	35	50	42	8	12.5	1223.5	1293.5	440	
	180	A140	3	55	45	55	48	0.5	0	1223.5	1293.5	440	A140	3	55	35	55	48	3	17.5	1223.5	1293.5	440	
	200	A180	4	70	45	70	55	0	5.5	1229.5	1299.5	440	A180	4	70	35	70	55	0	1.5	1205.5	1275.5	440	
	225	A180	4	70	45	70	60	0	1.5	1255.5	1325.5	440	A180	4	70	35	70	60	0	21.5	1255.5	1325.5	440	
	250	A180	4	70	45	70	65	0	1.5	1255	1325	440												
	280	A200	4	80	45	80	75	0	17	1270.5	1340.5	440												
13 / 14	180												A140	3	55	40	55	48	3	12.5	1398.5	1468.5	440	
	200	A160	4	60	55	60	55	7.5	3	1404.5	1474.5	440	A160	4	60	40	60	55	0	20.5	1404.5	1474.5	440	
	225	A180	4	70	55	70	60	1.5	5	1430.5	1500.5	440	A180	4	70	40	70	60	0	16.5	1430.5	1500.5	440	
	250	A180	4	70	55	70	65	0	6.5	1430	1500	440	A180	4	70	40	70	65	0	16.5	1430	1500	440	
	280	A200	4	80	55	80	75	0	22	1446	1516	440	A225	4	90	40	90	75	7	25	1446	1516	440	
	315 <sup>2)</sup>	A225	4	90	55	90	80	5	24	1483	1553	440												
	315 MC <sup>9)</sup>	A225	4	90	55	90	80	5	24	1483	1553	440												
315 MD <sup>9)</sup>	A225	4	90	55	90	80	5	24	1483	1553	440													
15 / 16	200												A160	4	60	50	60	55	1	8.5	1635.5	1681.5	440	
	225	A200	4	80	70	80	60	4.5	0	1685.5	1731.5	440	A180	4	70	50	70	60	9	20.5	1685.5	1731.5	440	
	250	A200	4	80	70	80	65	4.5	0	1685.5	1731.5	440	A180	4	70	50	70	65	7	22.5	1685.5	1731.5	440	
	280	A200	4	80	70	80	75	11.5	8.5	1701	1747	440	A200	4	80	50	80	75	0	15	1671	1717	440	
	315 <sup>2)</sup>	A225	4	90	70	90	80	10	17	1738	1784	440	A225	4	90	50	90	80	0	22	1708	1754	440	
	315 MC <sup>9)</sup>	A225	4	90	70	90	80	10	17	1738	1784	440												
	315 MD <sup>9)</sup>	A225	4	90	70	90	80	10	17	1738	1784	440												
	315 LB <sup>9)</sup>	A225	4	90	70	90	80	10	17	1738	1784	440												
355 MB <sup>9)</sup>	A250	5	100	70	100	90	0	28	1533	1603	645													
17 / 18	225												A180	4	70	50	70	60	9	20.5	1733.5	1793.5	440	
	250												A180	4	70	50	70	65	7	22.5	1733.5	1793.5	440	
	280	A200	4	80	70	80	75	11.5	8.5	1749	1809	440	A200	4	80	50	80	75	0	15	1719	1779	440	
	315 <sup>2)</sup>	A225	4	90	70	90	80	9.5	17.5	1786	1846	440	A225	4	90	50	90	80	0	22	1756	1816	440	
	315 MC <sup>9)</sup>	A225	4	90	70	90	80	9.5	17.5	1786	1846	440												
	315 MD <sup>9)</sup>	A225	4	90	70	90	80	9.5	17.5	1786	1846	440												
	315 LB <sup>9)</sup>	A225	4	90	70	90	80	9.5	17.5	1786	1846	440												
	355 MB <sup>9)</sup>	A250	5	100	70	100	90	8	20	1788	1848	645												
355 LB <sup>9)</sup>	A280	5	110	70	110	90	8	20	1788	1848	645													

## Zahnradgetriebe

Schwingungsdämpfende  
Drehmomentstützen für  
Getriebegehäuse  
Bauarten H2, H3, H4, B2, B3, B4

## Gear Units

Vibration Reducing  
Torque Supports for  
Gear Housings  
Types H2, H3, H4, B2, B3, B4

## Réducteurs à engrenages

Amortissement de vibrations par  
supports de couple pour  
carters de réducteur  
Types H2, H3, H4, B2, B3, B4

K20/006

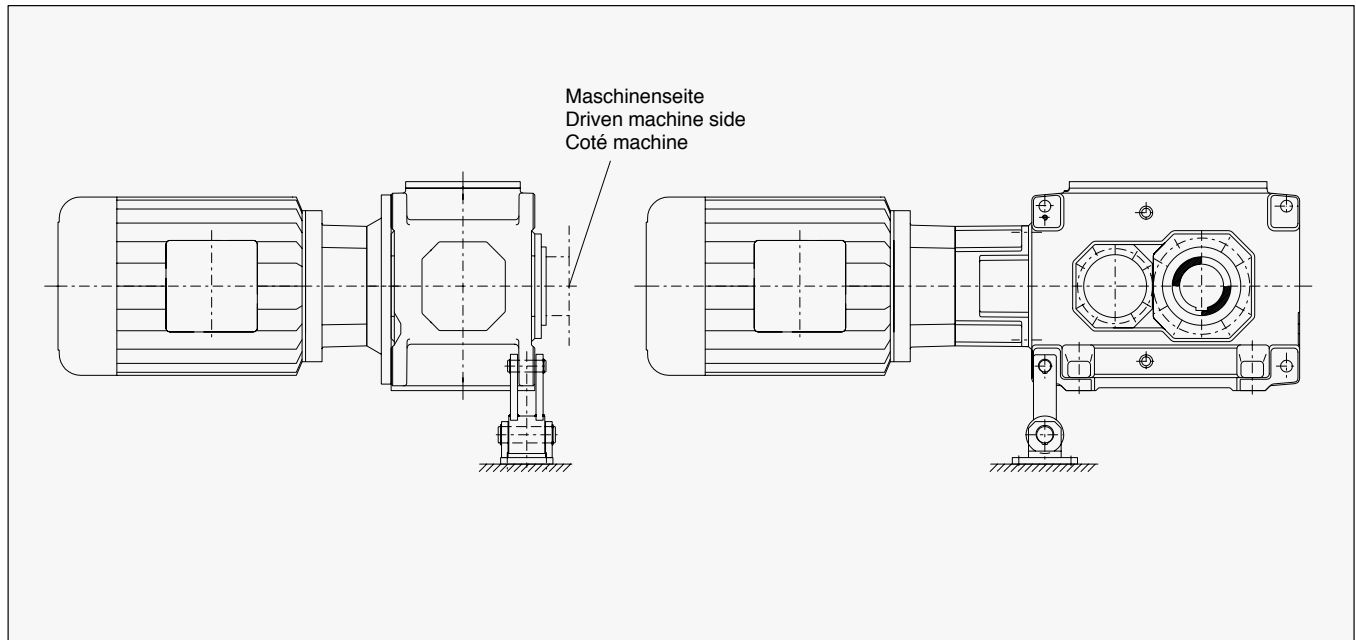

Das maximal übertragbare Drehmoment ist durch die Drehmomentstütze begrenzt:

$$\text{Es gilt: } T_{\max} = f_{\text{DMST}} \times T_{2\text{Nenn}}$$

The maximum transmissible torque is limited by the torque support:

$$T_{\max} = f_{\text{DMST}} \times T_{2\text{Nenn}}$$

Le couple maximum transmissible est limité par le bras de réaction:

$$\text{Est valable: } T_{\max} = f_{\text{DMST}} \times T_{2\text{Nenn}}$$

Tabelle / Table / Tableau 1

Getriebe- größe Gear unit size Taille réducteur	Spitzendrehmomentfaktor $f_{\text{DMST}}$ für Drehmomentstütze <sup>1)</sup> Peak torque factor $f_{\text{DMST}}$ for torque support Facteur de couple de pointe $f_{\text{DMST}}$ pour le bras de réaction					
	Bauart / Type / Type					
	H2	H3	H4	B2	B3	B4
4	1.3	–	–	1.2	1.2	–
5	1.9	2.0	–	1.2	1.6	2.0
6	1.6	1.7	–	1.2	1.4	1.7
7	2.0	2.0	2.0	1.3	1.8	2.0
8	1.7	2.0	2.0	1.2	1.6	2.0
9	1.5	1.6	1.7	1.2	1.2	1.7
10	1.3	1.4	1.4	1.2	1.2	1.4
11	2.0	2.0	2.0	1.9	2.0	1.2
12	2.0	2.0	2.0	1.8	2.0	1.2
13	–	2.0	2.0	1.4	1.8	2.0
14	–	1.9	2.0	1.3	1.7	2.0
15	–	1.5	1.7	–	1.4	1.6
16	–	1.4	1.5	–	1.3	1.5
17	–	1.2	1.3	–	1.2	1.3
18	–	1.2	1.2	–	1.2	1.2
19 - 26	Auf Anfrage / On request / Sur demande					

1) Die genannten Tabellenwerte sind Mindestwerte. Unter Angabe von Drehrichtung und Motortyp können gegebenenfalls höhere Spitzendrehmomente zugelassen werden. Rücksprache ist erforderlich!

1) The values in the table are minimum values. Dependent on direction of rotation and motor type, higher peak torques may possibly be allowed. Please consult us!

1) Les valeurs du tableaux sont des valeurs mini. Selon le sens de rotation et le type moteur, des couple de pointes plus hauts peuvent être éventuellement acceptés. Nous consulter!

## Zahnradgetriebe

Schwingungsdämpfende  
Drehmomentstützen für  
Getriebegehäuse  
Bauarten H2, H3, H4, B2, B3, B4

## Gear Units

Vibration Reducing  
Torque Supports for  
Gear Housings  
Types H2, H3, H4, B2, B3, B4

## Réducteurs à engrenages

Amortissement de vibrations par  
Supports de couple pour  
carters de réducteur  
Types H2, H3, H4, B2, B3, B4

K20/006

- Drehmomentstütze an der Arbeitsmaschinen-seite. (Stirnradgetriebe in Ausführung C, D, G, H, I nur auf Anfrage.)
- Bei Getrieben ohne Motorlaterne sind nur Kupplungen zulässig, die keine Querkräfte übertragen können.
- Drehmomentstütze in Kombination mit Lüfter nur auf Anfrage.

---

- Torque support on driven machine side. (Helical gear unit in C, D, G, H, I design on request only.)
- For gear units without motor bell housing only couplings not transmitting shear forces are allowed.
- Torque support in combination with fan on request only.

---

- Bras de réaction côté machine entraînée (réducteurs cylindriques en exécution C, D, G, H, I seulement sur demande.)
- Pour les réducteurs sans lanterne moteur, seuls les accouplements n'entraînant aucune force transversale / force de cisaillement sont acceptés.
- Bras de réaction en combinaison avec un ventilateur seulement sur demande.

Tabelle / Table / Tableau 2

Getriebe- größe Gear unit size Taille réducteur	A	B	Ø d <sub>3</sub>	F	H <sub>1</sub>	H <sub>2</sub>	m	n	s <sub>1</sub>	Metalastik- Buchse Bush Douille élastique	Gewicht Weight Poids kg
	mm										
4	160	110	19	116	200	65	120	70	15	079	6.8
5 + 6	200	160	19	170	250	90	160	120	20	095	16
7 + 8	320	200	19	195	400	140	260	130	25	772	37
9 + 10											42
11 + 12	400	300	24	320	500	175	320	240	30	805	155
13 + 14											159
15 + 16											163
17 + 18											167
19 - 26	Auf Anfrage / On request / Sur demande										

## Zahnradgetriebe

Getriebschwingen  
mit N-EUPEX-Kupplungen,  
IEC-Motoren und zugeordneten  
Kupplungen und Bremsen

## Gear Units

Gear Unit Swing-bases  
With N-EUPEX Couplings,  
IEC Motors and Assigned  
Couplings and Brakes

## Réducteurs à engrenages

Châssis supports  
avec accouplements N-EUPEX,  
moteurs IEC et les freins  
correspondants

K20/013

Tabelle / Table / Tableau 1

Größe Size Taille	IEC-Motor nach DIN 42673 IEC motor acc. to DIN 42673 Moteur IEC selon DIN 42673	N-EUPEX- Kupplung Größe N-EUPEX coupling size N-EUPEX accouplement taille  2)	N-EUPEX-Kupplung mit Trommelbremse nach DIN 15435 N-EUPEX coupling with drum brake acc. to DIN 15435 N-EUPEX accouplement avec frein à tambour selon DIN 15435		
	Wellenende Shaft end Arbre  D x E  mm		N-EUPEX- Kupplung Größe coupling size accouplement taille 3)	Bremstrommel Brake drum Tambour de frein  d x l  mm	Trommelbremse Größe Drum brake size Frein à tambour taille
<b>100</b>	28 x 60	80	125	200 x 75	TE 200
<b>112</b>	28 x 60	80	125	200 x 75	TE 200
<b>132</b>	38 x 80	95	125	200 x 75	TE 200
<b>160 M</b>	42 x 110	110	125	200 x 75	TE 200
<b>160 L</b>	42 x 110	125	125	200 x 75	TE 200
<b>180 M</b>	48 x 110	125	140	250 x 95	TE 250
<b>180 L</b>	48 x 110	140	140	250 x 95	TE 250
<b>200</b>	55 x 110	160	160	250 x 95	TE 250
<b>225</b>	60 x 140	160	180	315 x 118	TE 315
<b>250</b>	65 x 140	180	180	315 x 118	TE 315
<b>280 S</b>	75 x 140	200	225	400 x 150	TE 400
<b>280 M</b>	75 x 140	200	225	400 x 150	TE 400
<b>315 S</b>	80 x 170	200	225	400 x 150	TE 400
<b>315 M</b>	80 x 170	225	225	400 x 150	TE 400
<b>315 LB <sup>1)</sup></b>	80 x 170	250	250	500 x 190	TE 500
<b>355 MB <sup>1)</sup></b>	90 x 170	250	250	500 x 190	TE 500
<b>355 LB <sup>1)</sup></b>	90 x 170	280	280	500 x 190	TE 500
<b>400 MB <sup>1)</sup></b>	100 x 210	315	280	500 x 190	TE 500
<b>400 MD <sup>1)</sup></b>	100 x 210	315	280	500 x 190	TE 500

1) Loher-Baugrößen

2) Bauart A ab Größe 110;  
Bauart B bis Größe 95

3) Bauart P

N-EUPEX-Kupplungen mit Bremsscheibe  
auf Anfrage.

1) Loher sizes

2) Type A from size 110 up;  
Type B up to size 95

3) Type P

N-EUPEX couplings with brake disk  
on request.

1) Tailles Loher

2) Type A à partir de la taille 110;  
Type B jusqu' à la taille 95

3) Type P

Accouplements N-EUPEX avec disque de frein  
sur demande.



## Zahnradgetriebe

Getriebschwingen  
mit N-EUPEX-Kupplungen  
Bauarten B3, B4  
Größen 4 - 12

## Gear Units

Gear Unit Swing-bases  
With N-EUPEX Couplings  
Types B3, B4  
Sizes 4 - 12

## Réducteurs à engrenages

Châssis supports  
avec accouplements N-EUPEX  
Types B3, B4  
Tailles 4 - 12

K20/013



Tabelle / Table / Tableau 2

Größe Size Taille	Buchse Bush Douille	m	n	g	d <sub>3</sub>	A	B	d <sub>5</sub>	F	G	H <sub>1</sub>	H <sub>2</sub>	H <sub>3</sub>	l	s <sub>1</sub>	Gewicht / Weight / Poids	
																Stützbock Pedestal Chappe d'ancrage	Drehmomentstütze Torque support Bras de réaction
		mm	mm	mm	mm	mm	mm	mm	mm	mm	mm	mm	mm	mm	mm	kg	kg
4	069	95	65	M12	15	120	90	25	96	60	180	50	80	56	12	2.1	5.8
5 - 6	079	120	70	M16	19	160	110	32	116	75	200	65	105	72	15	5.3	11.8
7 - 10	095	160	120	M16	19	200	160	50	170	110	250	90	145	110	20	16	34
11 - 12	772	260	130	M16	19	320	200	100	195	180	400	140	230	120	25	50	82

# Zahnradgetriebe

Getriebeschwingen  
mit N-EUPEX-Kupplungen  
Bauart B3  
Größen 4 - 12

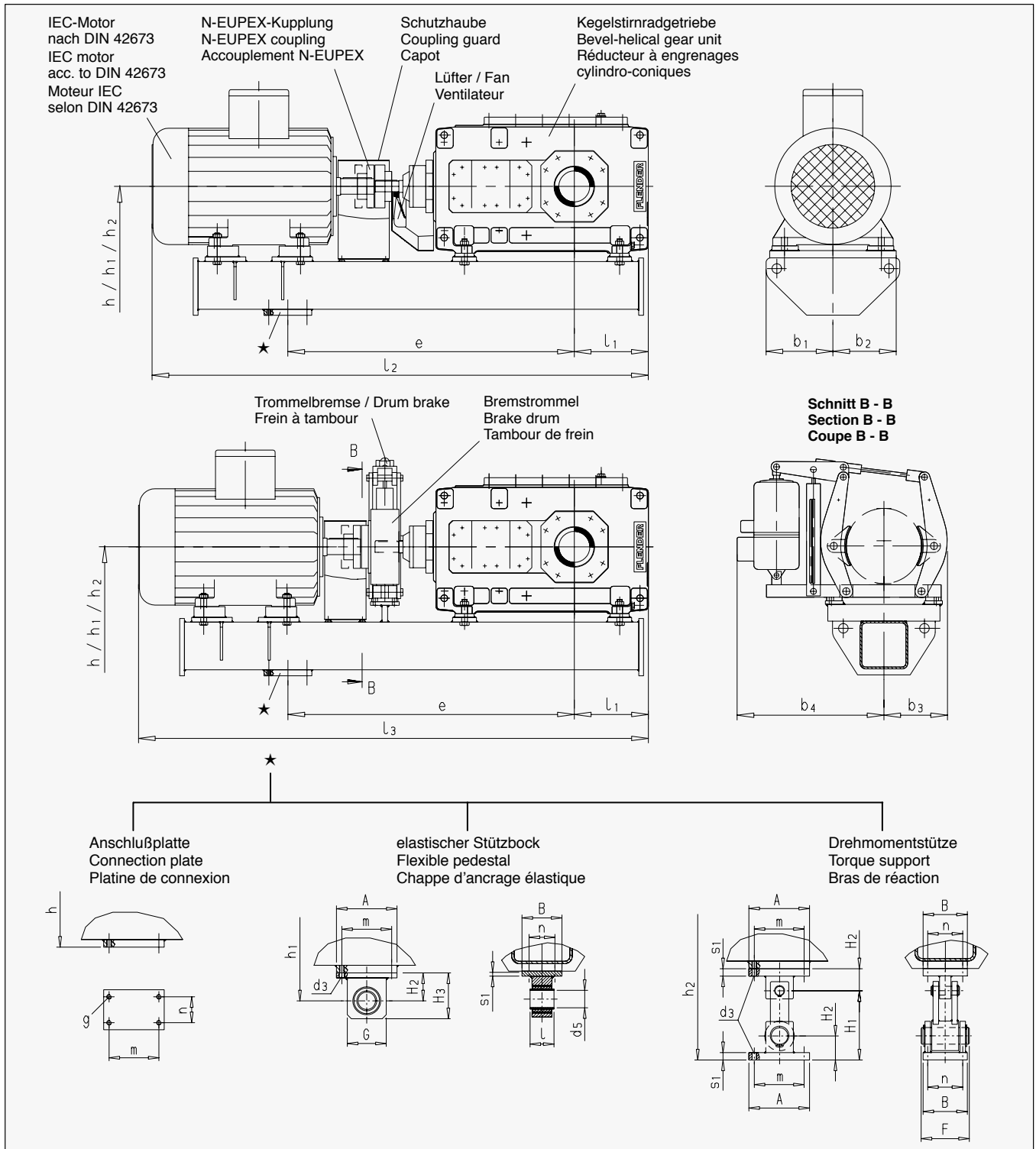
# Gear Units

Gear Unit Swing-bases  
With N-EUPEX Couplings  
Type B3  
Sizes 4 - 12

# Réducteurs à engrenages

Châssis supports  
avec accouplements N-EUPEX  
Type B3  
Tailles 4 - 12

K20/013

Tabelle / Table / Tableau 3

Bauart Größe Type Size Type Taille	IEC-Motor nach DIN 42673 IEC motor acc. to DIN 42673 Moteur IEC selon DIN 42673							N-EUPEX-Kupplung N-EUPEX coupling Accouplement N-EUPEX				N-EUPEX-Kupplung mit Trommelbremse N-EUPEX coupling with drum brake Accouplement N-EUPEX avec frein à tambour						
		e	h	h <sub>1</sub>	h <sub>2</sub>	l <sub>1</sub>	b <sub>1</sub>	b <sub>2</sub>	i <sub>N</sub> = 12.5 - 45 i <sub>N</sub> = 16 - 56		i <sub>N</sub> = 50 - 71 i <sub>N</sub> = 63 - 90		b <sub>3</sub>	b <sub>4</sub>	i <sub>N</sub> = 12.5 - 45 i <sub>N</sub> = 16 - 56		i <sub>N</sub> = 50 - 71 i <sub>N</sub> = 63 - 90	
									l <sub>2</sub> <sup>2)</sup>	l <sub>2</sub> <sup>* 2)</sup>	l <sub>2</sub> <sup>2)</sup>	l <sub>2</sub> <sup>* 2)</sup>			l <sub>3</sub> <sup>2)</sup>	l <sub>3</sub> <sup>* 2)</sup>	l <sub>3</sub> <sup>2)</sup>	l <sub>3</sub> <sup>* 2)</sup>
B3..4	132 S	950	380	430	610	190	160	145	—	—	1194	1194	170	470	—	—	1237	
	132 M							—	—	1232	1232	—			—	1275		
	160 M							1343	1343	1333	1333	1376			1376			
	160 L							1387	1387	1377	1387	1420			1420			
	180 M							1409	1409	1399	1409	1465			1465			
	180 L							1447	1452	—	—	1503			1503			
200 L	1529	1534	—	—	1585	1585	—	—										
B3..5	160 M	1000	450	515	715	205	185	170	—	—	1423	1423	170	470	—	—	1466	
	160 L							1487	1487	1467	1477	1515			1515			
	180 M							1509	1509	1489	1499	1555			1555			
	180 L							1547	1547	1527	1542	1593			1593			
	200 L							1629	1629	—	—	1675			1675			
	225 S							1682	1682	—	—	1759			1759			
225 M	1707	1707	—	—	1784	1784	—	—										
B3..6	160 M	1050	450	515	715	250	185	170	—	—	1503	1503	170	470	—	—	1546	
	160 L							1567	1567	1547	1557	1595			1595			
	180 M							1589	1589	1569	1579	1635			1635			
	180 L							1627	1627	1607	1622	1673			1673			
	200 L							1709	1709	—	—	1755			1755			
	225 S							1762	1762	—	—	1839			1839			
225 M	1787	1787	—	—	1864	1864	—	—										
B3..7	180 M	1150	540	630	880	250	215	185	—	—	1669	1669	210	590	—	—	1715	
	180 L							—	—	1707	1707	—			—	1753		
	200 L							1809	1809	1789	1789	1840			1840			
	225 S							1862	1862	1842	1842	1919			1919			
	225 M							1887	1887	1867	1867	1944			1944			
	250 M							1974	1974	—	—	2031			2031			
280 S	2048	2048	—	—	2147	2147												
280 M	2099	2099	—	—	2198	2198	—	—										
B3..8	180 M	1200	540	630	880	310	215	185	—	—	1774	1774	210	590	—	—	1820	
	180 L							—	—	1812	1812	—			—	1858		
	200 L							1914	1914	1894	1894	1945			1945			
	225 S							1967	1967	1947	1947	2024			2024			
	225 M							1992	1992	1972	1972	2049			2049			
	250 M							2079	2079	—	—	2136			2136			
280 S	2153	2153	—	—	2252	2252												
280 M	2204	2204	—	—	2303	2303	—	—										
B3..9	200 L	1350	630	720	970	300	260	215	—	—	1969	1969	210	590	—	—	2000	
	225 S							—	—	2022	2022	—			—	2079		
	225 M							2057	2057	2047	2047	2104			2104			
	250 M							2144	2144	2134	2134	2191			2191			
	280 S							2218	2218	2208	2208	2307			2307			
	280 M							2269	2269	—	—	2358			2358			
315 SB	2414	2414	—	—	2503	2503												
315 MB	2465	2475	—	—	2554	2554												
315 MD	2465	2475	—	—	2554	2554												
315 LB	2587	2607	—	—	—	—	—	—										
B3..10	200 L	1400	630	720	970	350	260	215	—	—	2069	2069	210	590	—	—	2100	
	225 S							—	—	2122	2122	—			—	2179		
	225 M							2157	2157	2147	2147	2204			2204			
	250 M							2244	2244	2234	2234	2291			2291			
	280 S							2318	2318	2308	2308	2407			2407			
	280 M							2369	2369	—	—	2458			2458			
315 SB	2514	2514	—	—	2603	2603												
315 MB	2565	2575	—	—	2654	2654												
315 MD	2565	2575	—	—	2654	2654												
315 LB	2687	2707	—	—	—	—	—	—										
B3..11	250 M	1550	740	880	1280	345	355	265	—	—	2349	2349	260	665	—	—	2396	
	280 S							—	—	2423	2423	—			—	2512		
	280 M							2499	2499	2474	2474	2563			2563			
	315 SB							2644	2644	2619	2619	2708			2708			
	315 MB							2695	2695	2670	2680	2759			2759			
	315 MD							2695	2695	—	—	2759			2759			
315 LB	2817	2817	—	—	2929	2929												
355 MB	2886	2886	—	—	2998	2998												
355 LB	2956	2961	—	—	3073	3073	—	—										
B3..12	250 M	1600	740	880	1280	430	355	265	—	—	2504	2504	260	665	—	—	2551	
	280 S							—	—	2578	2578	—			—	2667		
	280 M							2654	2654	2679	2629	2718			2718			
	315 SB							2799	2799	2774	2774	2863			2863			
	315 MB							2850	2850	2825	2835	2914			2914			
	315 MD							2850	2850	—	—	2914			2914			
315 LB	2972	2972	—	—	3084	3084												
355 MB	3041	3041	—	—	3153	3153												
355 LB	3111	3116	—	—	3228	3228	—	—										

# Zahnradgetriebe

Getriebeschwingen  
mit N-EUPEX-Kupplungen  
Bauart B4  
Größen 5 - 12

# Gear Units

Gear Unit Swing-bases  
With N-EUPEX Couplings  
Type B4  
Sizes 5 - 12

# Réducteurs à engrenages

Châssis supports  
avec accouplements N-EUPEX  
Type B4  
Tailles 5 - 12

K20/013

Tabelle / Table / Tableau 4

Bauart Größe Type Size Type Taille	IEC-Motor nach DIN 42673 IEC motor acc. to DIN 42673 Moteur IEC selon DIN 42673							N-EUPEX-Kupplung N-EUPEX coupling Accouplement N-EUPEX			N-EUPEX-Kupplung mit Trommelbremse N-EUPEX coupling with drum brake Accouplement N-EUPEX avec frein à tambour			
		e	h	h <sub>1</sub>	h <sub>2</sub>	l <sub>1</sub>	b <sub>1</sub>	b <sub>2</sub>	i <sub>N</sub> = 80 - 180	i <sub>N</sub> = 200 - 315	b <sub>3</sub>	b <sub>4</sub>	i <sub>N</sub> = 80 - 180	i <sub>N</sub> = 200 - 315
									i <sub>N</sub> = 100 - 224	i <sub>N</sub> = 250 - 400			i <sub>N</sub> = 100 - 224	i <sub>N</sub> = 250 - 400
								l <sub>2</sub> <sup>2)</sup>				l <sub>3</sub> <sup>2)</sup>		
mm														
B4..5	100 LD	1000	450	515	715	205	185	115	–	1256	170	470	–	1309
	112 M							130	1267	1262			1315	1315
	132 S							145	1319	1314			1367	1367
	132 M							170	1357	1352			1405	1405
	160 M							185	1458	–			1506	–
	160 L							185	1502	–			1550	–
180 M	210	1524	–	1595	–									
B4..6	100 LD	1050	450	515	715	250	185	115	–	1336	170	470	–	1389
	112 M							130	1347	1342			1395	1395
	132 S							145	1399	1394			1447	1447
	132 M							170	1437	1432			1485	1485
	160 M							185	1538	–			1586	–
	160 L							185	1882	–			1630	–
180 M	210	1604	–	1675	–									
B4..7	132 S	1150	540	630	880	250	215	145	–	1479	170	470	–	1552
	132 M							170	1527	1517			1560	1560
	160 M							185	1628	1618			1661	1661
	160 L							210	1672	1662			1705	1705
	180 M							210	1694	–			1750	–
	180 L							210	1732	–			1788	–
200 L	215	1814	–	1870	–									
B4..8	132 S	1200	540	630	880	310	215	145	–	1584	170	470	–	1627
	132 M							170	1632	1622			1665	1665
	160 M							185	1733	1723			1766	1766
	160 L							210	1777	1767			1810	1810
	180 M							210	1799	–			1855	–
	180 L							210	1837	–			1893	–
200 L	215	1919	–	1975	–									
B4..9	132 M	1350	630	720	970	300	260	145	–	1682	170	470	–	1725
	160 M							170	–	1783			–	1826
	160 L							185	1847	1827			1875	1870
	180 M							210	1969	1849			1915	1915
	180 L							210	1907	1887	1953	1953		
	200 L							215	1989	–	2035	–		
	225 S							240	2042	–	2119	–		
	225 M							260	2067	–	2144	–		
250 M	305	2154	–	2231	–									
B4..10	132 M	1400	630	720	970	350	260	145	–	1782	170	470	–	1825
	160 M							170	–	1883			–	1926
	160 L							185	1947	1927			1975	1970
	180 M							210	1969	1949			2015	2015
	180 L							210	2007	1987	2053	2053		
	200 L							215	2089	–	2135	–		
	225 S							240	2142	–	2219	–		
	225 M							260	2167	–	2244	–		
250 M	305	2254	–	2331	–									
B4..11	160 L	1550	740	880	1280	345	270	170	–	2062	170	470	–	2090
	180 M							185	–	2084			–	2130
	180 L							210	2142	2122			2173	2168
	200 L							215	2224	2204			2255	2250
	225 S							240	2277	2257	2334	2334		
	225 M							260	2302	–	2359	–		
	250 M							260	2389	–	2446	–		
	280 S							355	2463	–	2562	–		
280 M	355	2514	–	2613	–									
B4..12	160 L	1600	740	880	1280	430	270	170	–	2217	170	470	–	2245
	180 M							185	–	2239			–	2285
	180 L							210	2297	2277			2328	2323
	200 L							215	2379	2359			2410	2405
	225 S							240	2432	2412	2489	2489		
	225 M							260	2457	–	2514	–		
	250 M							260	2544	–	2601	–		
	280 S							355	2618	–	2717	–		
280 M	355	2669	–	2768	–									

1) Auf Anfrage

2) l<sub>2</sub>, l<sub>2</sub><sup>\*</sup>, l<sub>3</sub>, l<sub>3</sub><sup>\*</sup> für Loher-Normmotoren  
l<sub>2</sub><sup>\*</sup>, l<sub>3</sub><sup>\*</sup> für Getriebe mit Lüfter

Gewicht der Getriebeschwinge auf Anfrage

1) On request

2) l<sub>2</sub>, l<sub>2</sub><sup>\*</sup>, l<sub>3</sub>, l<sub>3</sub><sup>\*</sup> for Loher standard motors  
l<sub>2</sub><sup>\*</sup>, l<sub>3</sub><sup>\*</sup> for gear units with fan

Weight of gear unit swing-base on request

1) Sur demande

2) l<sub>2</sub>, l<sub>2</sub><sup>\*</sup>, l<sub>3</sub>, l<sub>3</sub><sup>\*</sup> pour moteurs standard Loher  
l<sub>2</sub><sup>\*</sup>, l<sub>3</sub><sup>\*</sup> pour réducteurs avec ventilateurs

Poids du châssis supports sur demande

## Zahnradgetriebe

Getriebschwingen  
mit N-EUPEX-Kupplungen  
Bauarten B3, B4  
Größen 13 - 18

## Gear Units

Gear Unit Swing-bases  
With N-EUPEX Couplings  
Types B3, B4  
Sizes 13 - 18

## Réducteurs à engrenages

Châssis supports  
avec accouplements N-EUPEX  
Types B3, B4  
Tailles 13 - 18

K20/013



Tabelle / Table / Tableau 5

Größe Size Taille	Buchse Bush Douille	m	n	g	d <sub>3</sub>	A	B	d <sub>5</sub>	F	G	H <sub>1</sub>	H <sub>2</sub>	H <sub>3</sub>	l	s <sub>1</sub>	Gewicht / Weight / Poids	
																Stützbock Pedestal Chappe d'ancrage	Drehmomentstütze Torque support Bras de réaction
		mm	mm	mm	mm	mm	mm	mm	mm	mm	mm	mm	mm	mm	mm	kg	kg
13 - 14	772	260	130	∅ 19	19	320	200	100	195	180	400	140	230	120	25	50	82
15 - 18	805	320	240	∅ 24	24	400	300	124	320	240	500	175	285	230	30	95	220

## Zahnradgetriebe

Getriebeschwingen  
mit N-EUPEX-Kupplungen  
Bauart B3  
Größen 13 - 18

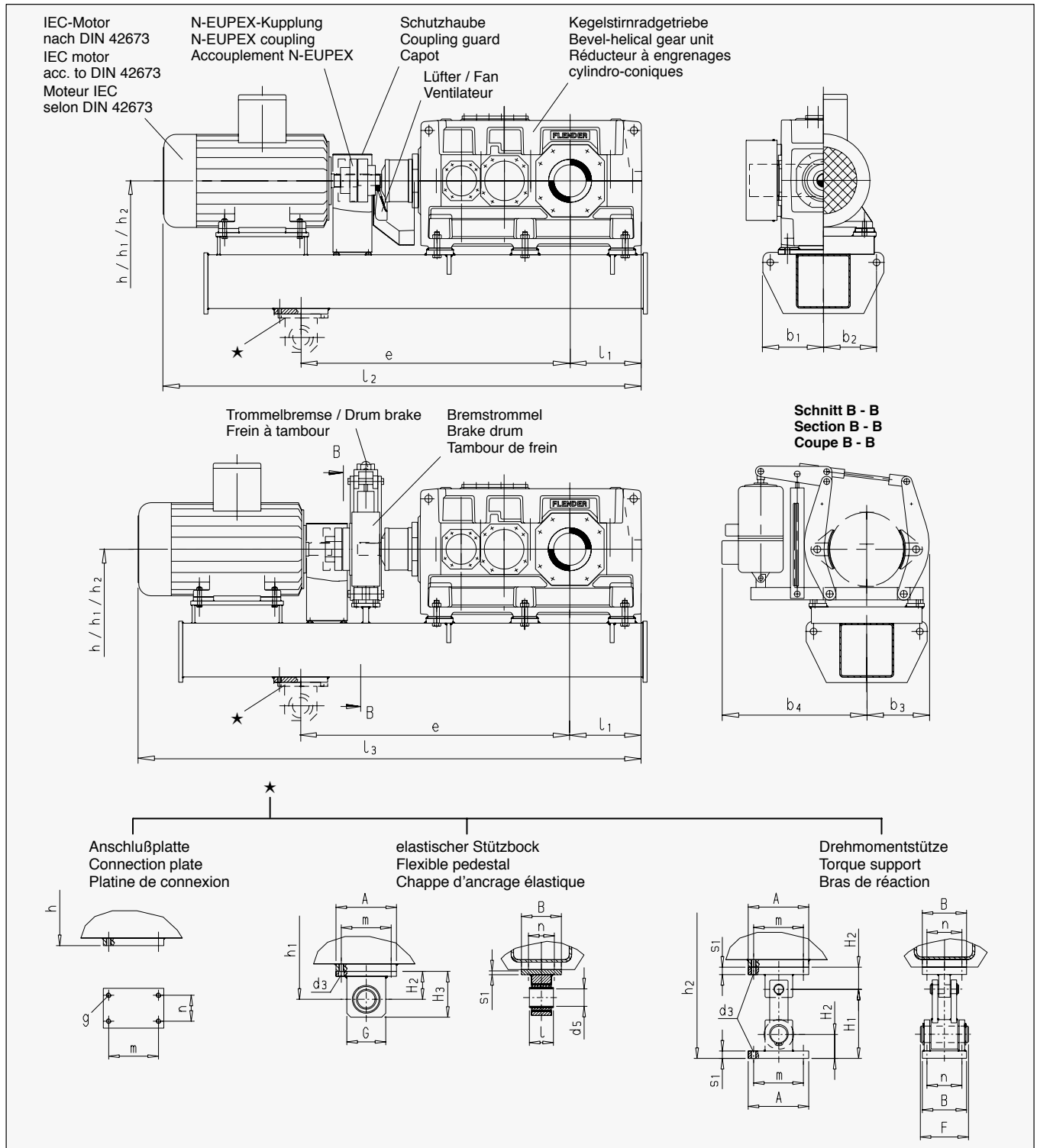
## Gear Units

Gear Unit Swing-bases  
With N-EUPEX Couplings  
Type B3  
Sizes 13 - 18

## Réducteurs à engrenages

Châssis supports  
avec accouplements N-EUPEX  
Type B3  
Tailles 13 - 18

K20/013

Tabelle / Table / Tableau 6

Bauart Größe Type Size Type Taille	IEC-Motor nach DIN 42673 IEC motor acc. to DIN 42673 Moteur IEC selon DIN 42673	e   h   h <sub>1</sub>   h <sub>2</sub>   l <sub>1</sub>   b <sub>1</sub>						N-EUPEX-Kupplung N-EUPEX coupling Accouplement N-EUPEX				N-EUPEX-Kupplung mit Trommelbremse N-EUPEX coupling with drum brake Accouplement N-EUPEX avec frein à tambour						
								b <sub>2</sub>	i <sub>N</sub> = 12.5 - 45		i <sub>N</sub> = 50 - 71		b <sub>3</sub>	b <sub>4</sub>	i <sub>N</sub> = 12.5 - 45		i <sub>N</sub> = 50 - 71	
									l <sub>2</sub> <sup>2)</sup>	l <sub>2</sub> <sup>* 2)</sup>	l <sub>2</sub> <sup>2)</sup>	l <sub>2</sub> <sup>* 2)</sup>			l <sub>3</sub> <sup>2)</sup>	l <sub>3</sub> <sup>* 2)</sup>	l <sub>3</sub> <sup>2)</sup>	l <sub>3</sub> <sup>* 2)</sup>
mm																		
B3..13	280 M	1750	800	940	1340	405	345	300	-	-	2729	2729	310	765	-	2788		
	315 SB							-	-	2874	2874	-			2933			
	315 MB							2950	2950	2925	2925	2999			2984			
	315 MD							2950	2950	2925	2925	2999			2984			
	315 LB							3072	3072	3047	3047	3154			3154			
	355 MB							3141	3141	-	-	3223			-			
	355 LB							3211	3211	-	-	3298			-			
	400 MB							3471	3471	-	-	3558			-			
	400 MD							3471	3471	-	-	3558			-			
B3..14	280 M	1750	800	940	1340	475	345	300	-	-	2869	2869	310	765	-	2928		
	315 SB							-	-	3014	3014	-			3073			
	315 MB							3090	3090	3065	3065	3139			3124			
	315 MD							3090	3090	3065	3065	3139			3124			
	315 LB							3212	3212	3187	3187	3294			3294			
	355 MB							3281	3281	-	-	3363			-			
	355 LB							3351	3351	-	-	3438			-			
	400 MB							3611	3611	-	-	3698			-			
	400 MD							3611	3611	-	-	3698			-			
B3..15	315 MB	2000	975	1150	1650	485	345	330	-	-	3247	3247	310	765	-	3306		
	315 MD								-	-	3247	3247			-		3306	
	315 LB								-	-	3369	3369			-		3476	
	355 MB							380	3463	3463	3438	3438	3545	3545				
	355 LB								3533	3533	3508	3513	3620	3620				
	400 MB								3793	3793	-	-	3880	-				
	400 MD								3793	3793	-	-	3880	-				
B3..16	315 MB	2000	975	1150	1650	530	345	330	-	-	3338	3338	310	765	-	3397		
	315 MD								-	-	3338	3338			-		3397	
	315 LB								-	-	3460	3460			-		3567	
	355 MB							380	3554	3554	3529	3529	3636	3636				
	355 LB								3624	3624	3599	3604	3711	3711				
	400 MB								3884	3884	-	-	3971	-				
	400 MD								3884	3884	-	-	3971	-				
B3..17	315 MB	2200	1025	1200	1700	525	500	330	-	-	3632	3632	385	840	-	3709		
	355 MD								-	-	3701	3701			-		3778	
	355 LB							420	3806	3806	3771	3771			3868		3853	
	400 MB								4066	4066	4031	4031			4128		4113	
	400 MD								4066	4066	4031	4031			4128		4113	
B3..18	315 LB	2200	1025	1200	1700	585	500	330	-	-	3752	3752	385	840	-	3829		
	355 MB								-	-	3821	3821			-		3898	
	355 LB							420	3926	3926	3891	3891			3988		3973	
	400 MB								4186	4186	4151	4151			4248		4233	
	400 MD								4186	4186	4151	4151			4248		4233	

1) Auf Anfrage

2) l<sub>2</sub>, l<sub>2</sub><sup>\*</sup>, l<sub>3</sub>, l<sub>3</sub><sup>\*</sup> für Loher-Normmotoren  
l<sub>2</sub><sup>\*</sup>, l<sub>3</sub><sup>\*</sup> für Getriebe mit Lüfter

Gewicht der Getriebeschwinge auf Anfrage

1) On request

2) l<sub>2</sub>, l<sub>2</sub><sup>\*</sup>, l<sub>3</sub>, l<sub>3</sub><sup>\*</sup> for Loher standard motors  
l<sub>2</sub><sup>\*</sup>, l<sub>3</sub><sup>\*</sup> for gear units with fan

Weight of gear unit swing-base on request

1) Sur demande

2) l<sub>2</sub>, l<sub>2</sub><sup>\*</sup>, l<sub>3</sub>, l<sub>3</sub><sup>\*</sup> pour moteurs standard Loher  
l<sub>2</sub><sup>\*</sup>, l<sub>3</sub><sup>\*</sup> pour réducteurs avec ventilateurs

Poids du châssis supports sur demande

# Zahnradgetriebe

Getriebeschwingen  
mit N-EUPEX-Kupplungen  
Bauart B4  
Größen 13 - 18

# Gear Units

Gear Unit Swing-bases  
With N-EUPEX Couplings  
Type B4  
Sizes 13 - 18

# Réducteurs à engrenages

Châssis supports  
avec accouplements N-EUPEX  
Type B4  
Tailles 13 - 18

K20/013

Tabelle / Table / Tableau 7

Bauart Größe Type Size Type Taille	IEC-Motor nach DIN 42673 IEC motor acc. to DIN 42673 Moteur IEC selon DIN 42673							N-EUPEX-Kupplung N-EUPEX coupling Accouplement N-EUPEX			N-EUPEX-Kupplung mit Trommelbremse N-EUPEX coupling with drum brake Accouplement N-EUPEX avec frein à tambour				
		e	h	h <sub>1</sub>	h <sub>2</sub>	l <sub>1</sub>	b <sub>1</sub>	b <sub>2</sub>	i <sub>N</sub> = 80 - 180	i <sub>N</sub> = 200 - 315	b <sub>3</sub>	b <sub>4</sub>	i <sub>N</sub> = 80 - 180	i <sub>N</sub> = 200 - 315	
									i <sub>N</sub> = 100 - 224	i <sub>N</sub> = 250 - 400			i <sub>N</sub> = 100 - 224	i <sub>N</sub> = 250 - 400	
								mm							
								l <sub>2</sub> <sup>2)</sup>	l <sub>2</sub> <sup>2)</sup>			l <sub>3</sub> <sup>2)</sup>	l <sub>3</sub> <sup>2)</sup>		
B4..13	180 M	1750	800	940	1340	405	345	185	–	2324	210	590	–	2355	
	180 L							–	2362	–			2393		
	200 L							215	–	2444			–	2475	
	225 S							–	2507	–			2497	2554	2554
	225 M							240	2532	–			2522	2579	2579
	250 M							265	2619	–			2609	2666	2666
	280 S							300	2693	–			–	2782	–
	280 M							–	2744	–			–	2833	–
	315 SB							330	2889	–			–	2978	–
	315 MB							–	2940	–			–	3029	–
B4..14	180 M	1750	800	940	1340	475	345	185	–	2464	210	590	–	2495	
	180 L							–	2502	–			2533		
	200 L							215	–	2584			–	2615	
	225 S							–	2647	–			2637	2694	2694
	225 M							240	2672	–			2662	2719	2719
	250 M							265	2759	–			2749	2806	2806
	280 S							300	2833	–			–	2922	–
	280 M							–	2884	–			–	2973	–
	315 SB							330	3029	–			–	3118	–
	315 MB							–	3080	–			–	3169	–
B4..15	200 L	2000	975	1150	1650	485	345	215	–	2766	210	590	–	2797	
	225 S							–	2819	–			2866		
	225 M							240	–	2844			–	2891	
	250 M							265	2956	–			2931	2995	2978
	280 S							300	3030	–			3005	3111	3094
	280 M							–	3081	–			3056	3145	3145
	315 SB							330	3226	–			–	3290	–
	315 MB							–	3277	–			–	3341	–
	315 MD							–	3277	–			–	3341	–
	315 LB							385	3399	–			–	3511	–
B4..16	200 L	2000	975	1150	1650	530	345	215	–	2857	210	590	–	2888	
	225 S							–	2910	–			2957		
	225 M							240	–	2935			–	2982	
	250 M							265	3047	–			3022	3086	3069
	280 S							300	3121	–			3096	3202	3185
	280 M							–	3172	–			3147	3236	3236
	315 SB							330	3317	–			–	3381	–
	315 MB							–	3368	–			–	3432	–
	315 MD							–	3368	–			–	3432	–
	315 LB							385	3490	–			–	3602	–
B4..17	225 M	2200	1025	1200	1700	525	500	240	–	2932	260	665	–	2979	
	250 M							265	–	3019			–	3066	
	280 S							300	3118	–			3093	3199	3182
	280 M							–	3169	–			3144	3233	3233
	315 SB							330	3314	–			3289	3378	3378
	315 MB							–	3365	–			–	3429	–
	315 MD							–	3365	–			–	3429	–
	315 LB							380	3487	–			–	3599	–
	355 MB							–	3556	–			–	3668	–
	355 LB							–	3626	–			–	3743	–
B4..18	225 M	2200	1025	1200	1700	585	500	240	–	3052	260	665	–	3099	
	250 M							265	–	3139			–	3186	
	280 S							300	3238	–			3213	3319	3302
	280 M							–	3289	–			3264	3353	3353
	315 SB							330	3434	–			3409	3498	3498
	315 MB							–	3485	–			–	3549	–
	315 MD							–	3485	–			–	3549	–
	315 LB							380	3607	–			–	3719	–
	355 MB							–	3676	–			–	3788	–
	355 LB							–	3746	–			–	3863	–

1) Auf Anfrage

2) l<sub>2</sub>, l<sub>2</sub><sup>\*</sup>, l<sub>3</sub>, l<sub>3</sub><sup>\*</sup> für Loher-Normmotoren  
l<sub>2</sub><sup>\*</sup>, l<sub>3</sub><sup>\*</sup> für Getriebe mit Lüfter

Gewicht der Getriebeschwinge auf Anfrage

1) On request

2) l<sub>2</sub>, l<sub>2</sub><sup>\*</sup>, l<sub>3</sub>, l<sub>3</sub><sup>\*</sup> for Loher standard motors  
l<sub>2</sub><sup>\*</sup>, l<sub>3</sub><sup>\*</sup> for gear units with fan

Weight of gear unit swing-base on request

1) Sur demande

2) l<sub>2</sub>, l<sub>2</sub><sup>\*</sup>, l<sub>3</sub>, l<sub>3</sub><sup>\*</sup> pour moteurs standard Loher  
l<sub>2</sub><sup>\*</sup>, l<sub>3</sub><sup>\*</sup> pour réducteurs avec ventilateurs

Poids du châssis supports sur demande

## Zahnradgetriebe

Getriebeschwinge mit  
FLUDEX-Strömungskupplungen,  
IEC-Motoren und zugeordneten  
Kupplungen und Bremsen

## Gear Units

Gear Unit Swing-bases  
With FLUDEX Fluid Couplings,  
IEC Motors and Assigned  
Couplings and Brakes

## Réducteurs à engrenages

Châssis supports avec  
coupleurs hydrauliques  
FLUDEX, moteurs IEC et les  
freins correspondants

K20/013

Tabelle / Table / Tableau 8

IEC-Motor nach DIN 42673 IEC motor acc. to DIN 42673 Moteur IEC selon DIN 42673  Größe Size Taille  1500 min <sup>-1</sup>	FLUDEX- <sup>3)</sup> Kupplung ohne Vorkammer, Anfahrfaktor 2 Coupling without delay chamber, starting factor 2 Coupleur sans chambre de retardement, facteur de démarrage 2			FLUDEX- <sup>3)</sup> Kupplung mit Vorkammer, Anfahrfaktor 1.5 Coupling with delay chamber, starting factor 1.5 Coupleur avec chambre de retardement, facteur de démarrage 1.5		
	Bauart / Größe Type / Size Type / Taille	FLUDEX-Kupplung Bauart / Größe Coupling Type / Size Coupleur Type / Taille	Trommelbremse Größe Drum brake size Frein à tambour taille	Bauart / Größe Type / Size Type / Taille	FLUDEX-Kupplung Bauart / Größe Coupling Type / Size Coupleur Type / Taille	Trommelbremse Größe Drum brake size Frein à tambour taille
<b>100</b>	FAD 222	FADB 222	TE 200			
<b>112</b>	FAD 222	FADB 222	TE 200			
<b>132 S</b>	FAD 222	FADB 222	TE 200			
<b>132 M</b>	FAD 297	FADB 297	TE 200			
<b>160</b>	FAD 297	FADB 297	TE 200	FND 370	FNDB 370	TE 315
<b>180 M</b>	FAD 297	FADB 297	TE 250	FND 370	FNDB 370	TE 315
<b>180 L</b>	FAD 342	FADB 342	TE 250	FND 370	FNDB 370	TE 315
<b>200</b>	FAD 342	FADB 342	TE 250	FND 370	FNDB 370	TE 315
<b>225</b>	FAD 395	FADB 395	TE 315	FND 370	FNDB 370	TE 315
<b>250</b>	FAD 395	FADB 395	TE 315	FND 425	FNDB 425	TE 315
<b>280</b>	FAD 450	FADB 450	TE 315	FND 425	FNDB 425	TE 315
<b>315 S</b>	FAD 516	FADB 516	TE 400	FND 490	FNDB 490	TE 400
<b>315 M</b>	FAD 516	FADB 516	TE 400	FND 490	FNDB 490	TE 400
<b>315 LB<sup>1)</sup></b>	FAD 590	FADB 590	TE 500	FND 565	FNDB 565	TE 500
<b>355 MB<sup>1)</sup></b>	FAD 590	FADB 590	TE 500	FND 565	FNDB 565	TE 500
<b>355 LB<sup>1)</sup></b>	FAD 590	FADB 590	TE 500	FND 565	FNDB 565	TE 500

1) Loher-Baugrößen

3) EOC-Abschaltung auf Anfrage

FLUDEX-Kupplungen mit Bremsscheibe  
auf Anfrage

1) Loher sizes

3) EOC circuit breaker on request

FLUDEX couplings with brake disk  
on request

1) Tailles Loher

3) Limiteur EOC sur demande

Coupleurs FLUDEX avec disque de frein  
sur demande

## Zahnradgetriebe

Getriebebeschwingen mit  
FLUDEX-Strömungskupplungen  
Bauarten B3, B4  
Größen 4 - 12

## Gear Units

Gear Unit Swing-bases  
With FLUDEX Fluid Couplings  
Types B3, B4  
Sizes 4 - 12

## Réducteurs à engrenages

Châssis supports avec coupleurs  
hydrauliques FLUDEX  
Types B3, B4  
Tailles 4 - 12

K20/013



Tabelle / Table / Tableau 9

Größe Size Taille	Buchse Bush Douille	m	n	g	d <sub>3</sub>	A	B	d <sub>5</sub>	F	G	H <sub>1</sub>	H <sub>2</sub>	H <sub>3</sub>	l	s <sub>1</sub>	Gewicht / Weight / Poids	
																Stützbock Pedestal Chappe d'ancrage	Drehmomentstütze Torque support Bras de réaction
		mm	mm	mm	mm	mm	mm	mm	mm	mm	mm	mm	mm	mm	mm	kg	kg
4	069	95	65	M12	15	120	90	25	96	60	180	50	80	56	12	2.1	5.8
5 - 6	079	120	70	M16	19	160	110	32	116	75	200	65	105	72	15	5.3	11.8
7 - 10	095	160	120	M16	19	200	160	50	170	110	250	90	145	110	20	16	34
11 - 12	772	260	130	M16	19	320	200	100	195	180	400	140	230	120	25	50	82

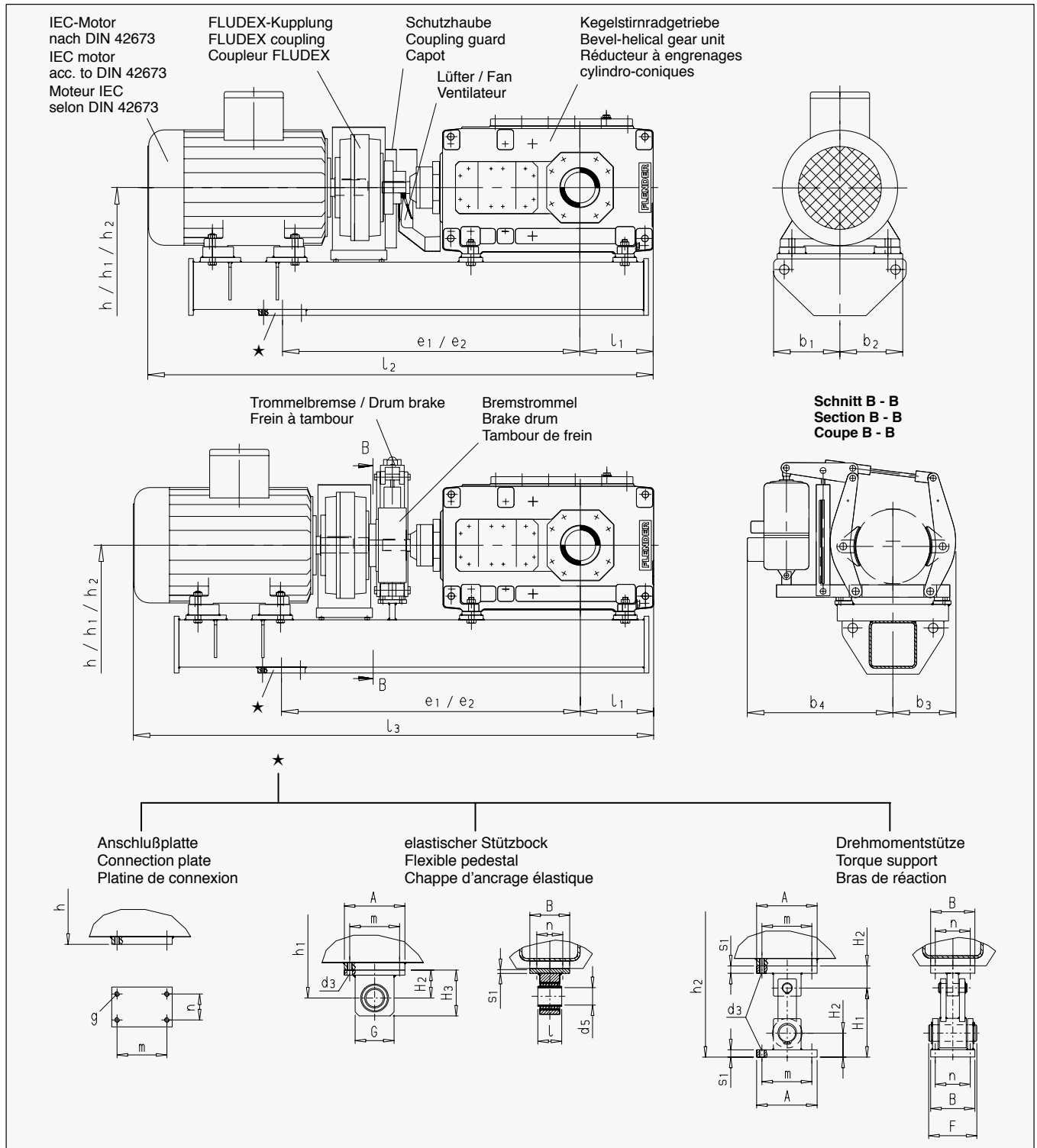

### Zahnradgetriebe

Getriebeschwinge mit  
FLUDEX-Strömungskupplungen  
Bauart B3  
Größen 4 - 12

### Gear Units

Gear Unit Swing-bases  
With FLUDEX Fluid Couplings  
Type B3  
Sizes 4 - 12

### Réducteurs à engrenages

Châssis supports avec coupleurs  
hydrauliques FLUDEX  
Type B3  
Tailles 4 - 12

K20/013

Tabelle / Table / Tableau 10																												
Bauart Größe Type Size Type Taille	IEC-Motor nach DIN 42673 IEC motor acc. to DIN 42673 Moteur IEC selon DIN 42673	FLUDEX-Kupplung FLUDEX coupling Coupleur FLUDEX										FLUDEX-Kupplung mit Trommelbremse FLUDEX coupling with drum brake Coupleur FLUDEX avec frein à tambour																
		e <sub>1</sub> <sup>6)</sup>	e <sub>2</sub> <sup>6)</sup>	h	h <sub>1</sub>	h <sub>2</sub>	l <sub>1</sub>	b <sub>1</sub>	i <sub>N</sub> = 12.5 - 45				i <sub>N</sub> = 50 - 71				b <sub>3</sub> <sup>5)</sup>	b <sub>4</sub> <sup>5)</sup>	i <sub>N</sub> = 12.5 - 45		i <sub>N</sub> = 50 - 71							
									i <sub>N</sub> = 16 - 56				i <sub>N</sub> = 63 - 90						i <sub>N</sub> = 16 - 56		i <sub>N</sub> = 63 - 90							
									f <sub>A</sub> = 2 <sup>4)</sup>		f <sub>A</sub> = 1.5 <sup>4)</sup>		f <sub>A</sub> = 2 <sup>4)</sup>		f <sub>A</sub> = 1.5 <sup>4)</sup>				f <sub>A</sub> = 2 <sup>4)</sup>	f <sub>A</sub> = 1.5 <sup>4)</sup>	f <sub>A</sub> = 2 <sup>4)</sup>	f <sub>A</sub> = 1.5 <sup>4)</sup>						
b <sub>2</sub>	l <sub>2</sub> <sup>2)</sup>	l <sub>2</sub> <sup>*2)</sup>	l <sub>2</sub> <sup>2)</sup>	l <sub>2</sub> <sup>*2)</sup>	l <sub>2</sub> <sup>2)</sup>	l <sub>2</sub> <sup>*2)</sup>	l <sub>2</sub> <sup>2)</sup>	l <sub>2</sub> <sup>*2)</sup>	l <sub>2</sub> <sup>2)</sup>	l <sub>2</sub> <sup>*2)</sup>	l <sub>2</sub> <sup>2)</sup>	l <sub>2</sub> <sup>*2)</sup>	l <sub>3</sub> <sup>2)</sup>	l <sub>3</sub> <sup>2)</sup>	l <sub>3</sub> <sup>2)</sup>	l <sub>3</sub> <sup>2)</sup>												
mm																												
B3..4	132 S	950	1250	380	430	610	190	160	145	-	-	-	-	1251	1243	-	-	170	470	-	-	1283	-					
	132 M							-	-	-	-	1342	1328	-	-	-	-	-	-	-	-	-	-	-	-	1368	-	
	160 M							-	-	-	-	1403	1413	-	-	-	-	-	-	-	-	-	-	-	-	1439	-	1439
	160 L							-	-	-	-	1447	1457	-	-	-	-	-	-	-	-	-	-	-	-	1483	-	1483
	180 M							-	-	-	-	1464	1469	-	-	-	-	-	-	-	-	-	-	-	-	1505	-	1505
	180 L							-	-	-	-	-	-	-	-	-	-	-	-	-	-	-	-	-	-	1601	-	-
200 L	-	-	-	-	-	-	-	-	-	-	-	-	-	-	-	-	-	-	1683	-	-							
B3..5	160 M	1050	1300	450	515	715	205	170	-	-	-	-	1493	1503	1704	1724	170	470	-	-	1529	1791						
	160 L							1557	1557	1758	1768	1537	1587	1748	1768	1578	1835	1573	1835									
	180 M							1576	1574	1780	1790	1554	1569	1770	1790	1595	1857	1595	1857									
	180 L							1650	1650	1818	1828	1630	1645	1808	1828	1691	1895	1691	1895									
	200 L							1732	1732	1900	1910	-	-	-	-	1773	1977	-	-									
	225 S							1) 1)	1922	1932	-	-	-	-	1) 1)	1999	-	-										
225 M	1) 1)	1947	1957	-	-	-	-	1) 1)	2024	-	-																	
B3..6	160 M	1100	1350	450	515	715	250	170	-	-	-	-	1573	1583	1784	1804	170	470	-	-	1609	1871						
	160 L							1635	1637	1838	1848	1617	1627	1828	1848	1658	1915	1653	1915									
	180 M							1654	1654	1860	1870	1634	1649	1850	1870	1675	1937	1675	1937									
	180 L							1730	1730	1898	1908	1710	1725	1888	1908	1771	1975	1771	1975									
	200 L							1812	1812	1980	1990	-	-	-	-	1853	2057	-	-									
	225 S							1) 1)	2002	2012	-	-	-	-	1) 1)	2079	-	-										
225 M	1) 1)	2027	2037	-	-	-	-	1) 1)	2104	-	-																	
B3..7	180 M	1250	1450	540	630	880	250	215	-	-	-	-	1734	1734	1940	1950	210	590	-	-	1755	2017						
	180 L							-	-	-	-	1810	1810	1978	1988	-	-	1851	2055									
	200 L							1912	1912	2080	2080	1892	1992	2060	2070	1938	2137	1933	2137									
	225 S							1928	1938	2102	2102	1918	1938	2082	2092	1981	2159	1981	2159									
	225 M							1953	1963	2127	2127	1943	1963	2107	2117	2006	2184	2006	2184									
	250 M							265	2040	2050	2271	2271	-	-	-	2093	2333	-	-									
280 S	2142	2162	2345	2345	-	-	-	-	2199	2407	-	-																
280 M	1) 1)	2396	2396	-	-	-	-	1) 1)	2458	-	-																	
B3..8	180 M	1300	1500	540	630	880	310	215	-	-	-	-	1839	1839	2045	2055	210	590	-	-	1860	2122						
	180 L							-	-	-	-	1915	1815	2083	2093	-	-	1956	2160									
	200 L							2017	2017	2185	2185	1997	1997	2165	2145	2043	2242	2038	2242									
	225 S							2033	2043	2207	2207	2023	2043	2187	2197	2086	2264	2086	2264									
	225 M							2058	2068	2232	2232	2048	2068	2212	2222	2111	2289	2111	2289									
	250 M							265	2145	2155	2376	2376	-	-	-	2198	2438	-	-									
280 S	2247	2267	2450	2450	-	-	-	-	2304	2512	-	-																
280 M	1) 1)	2501	2501	-	-	-	-	1) 1)	2563	-	-																	
B3..9	200 L	1450	1650	630	720	970	300	215	-	-	-	-	2072	2072	2240	2240	210	590	-	-	2098	2297						
	225 S							-	-	-	-	2088	2108	2262	2262	-	-	2141	2319									
	225 M							2123	2133	2297	2297	2113	2133	2287	2287	2166	2344	2166	2344									
	250 M							2210	2220	2441	2441	2200	2220	2431	2441	2253	2493	2253	2493									
	280 S							2312	2332	2515	2515	2302	2332	2505	2515	2359	2567	2359	2567									
	280 M							2363	2383	2566	2566	-	-	-	-	2410	2618	-	-									
315 SB	2592	2559	2729	2739	-	-	-	-	2597	2818	-	-																
315 MB	2580	2610	2780	2790	-	-	-	-	2648	2869	-	-																
315 MD	2580	2610	2780	2790	-	-	-	-	2648	2869	-	-																
315 LB	1) 1)	1) 1)	1) 1)	1) 1)	-	-	-	-	1) 1)	1) 1)	-	-																
B3..10	200 L	1500	1700	630	720	970	350	215	-	-	-	-	2172	2172	2340	2340	210	590	-	-	2198	2397						
	225 S							-	-	-	-	2188	2208	2362	2362	-	-	2241	2419									
	225 M							2223	2233	2397	2397	2213	2233	2387	2387	2266	2444	2266	2444									
	250 M							2310	2320	2541	2541	2300	2320	2531	2541	2353	2593	2353	2593									
	280 S							2412	2432	2615	2615	2402	2432	2605	2615	2459	2667	2459	2667									
	280 M							2463	2483	2666	2666	-	-	-	-	2510	2718	-	-									
315 SB	2629	2659	2829	2839	-	-	-	-	2697	2919	-	-																
315 MB	2680	2710	2880	2890	-	-	-	-	2748	2969	-	-																
315 MD	2680	2710	2880	2890	-	-	-	-	2748	2969	-	-																
315 LB	1) 1)	1) 1)	1) 1)	1) 1)	-	-	-	-	1) 1)	1) 1)	-	-																
B3..11	250 M	1650	1900	740	880	1280	345	355	265	-	-	-	-	2415	2425	2646	2646	260	665	-	-	2458	2698					
	280 S								-	-	-	-	2517	2537	2720	2720	-	-	2564	2772								
	280 M								2593	2593	2796	2796	2568	2588	2771	2771	2632	2840	2615	2823								
	315 SB								2744	2764	2959	2959	2734	2764	2934	2944	2802	3023	2802	3023								
	315 MB								2795	2815	3010	3010	2785	2815	2985	2995	2853	3074	2853	3074								
	315 MD								2795	2815	3010	3010	-	-	-	-	2853	3074	-	-								
315 LB	2950	2970	3189	3189	-	-	-	-	3047	3302	-	-																
355 MB	3019	3030	3258	3258	-	-	-	-	3116	3371	-	-																
355 LB	3089	3109	3328	3328	-	-	-	-	3186	3441	-	-																
B3..12	250 M	1700	1950	740	880	1280	430	355	265	-	-	-	-	2570	2580	2801	2801	260	665	-	-	2613	2853					
	280 S								-	-	-	-	2672	2692	2875	2875	-	-	2719	2927								
	280 M								2748	2748	2951	2951	2723	2743	2926	2926	2787	2995	2770	2978								
	315 SB								2899	2919	3114	3114	2889	2919	3089	3099	2957	3178	2957	3178								
	315 MB								2950	2970	3165	3165	2940	2970	3140	3150	3008	3229	3008	3229								
	315 MD								2950	2970	3165	3165	-	-	-	-	3008	3229	-	-								
315 LB	3105	3125	3344	3344	-	-	-	-	3202	3457	-	-																
355 MB	3174	3194	3413	3413	-	-	-	-	3271	3526	-	-																
355 LB	3244	3264	3483	3483	-	-	-	-	3341	3596	-	-																

# Zahnradgetriebe

Getriebeschwinge mit  
FLUDEX-Strömungskupplungen  
Bauart B4  
Größen 5 - 12

# Gear Units

Gear Unit Swing-bases  
With FLUDEX Fluid Couplings  
Type B4  
Sizes 5 - 12

# Réducteurs à engrenages

Châssis supports avec coupleurs  
hydrauliques FLUDEX  
Type B4  
Tailles 5 - 12

K20/013

Tabelle / Table / Tableau 11

Bauart Größe Type Size Type Taille	IEC-Motor nach DIN 42673 IEC motor acc. to DIN 42673 Moteur IEC selon DIN 42673								FLUDEX-Kupplung FLUDEX coupling Coupleur FLUDEX				FLUDEX-Kupplung mit Trommelbremse FLUDEX coupling with drum brake Coupleur FLUDEX avec frein à tambour						
		e <sub>1</sub> <sup>6)</sup>	e <sub>2</sub> <sup>6)</sup>	h	h <sub>1</sub>	h <sub>2</sub>	l <sub>1</sub>	b <sub>1</sub>	b <sub>2</sub>	i <sub>N</sub> = 80 - 180		i <sub>N</sub> = 200 - 315		b <sub>3</sub> <sup>5)</sup>	b <sub>4</sub> <sup>5)</sup>	i <sub>N</sub> = 80 - 180		i <sub>N</sub> = 200 - 315	
										f <sub>A</sub> = 2 <sub>4)</sub>	f <sub>A</sub> = 1.5 <sub>4)</sub>	f <sub>A</sub> = 2 <sub>4)</sub>	f <sub>A</sub> = 1.5 <sub>4)</sub>			f <sub>A</sub> = 2 <sub>4)</sub>	f <sub>A</sub> = 1.5 <sub>4)</sub>	f <sub>A</sub> = 2 <sub>4)</sub>	f <sub>A</sub> = 1.5 <sub>4)</sub>
mm																			
B4..5	100 LD	950	1250	450	515	715	205	185	115	-	-	1338	-	170	470	-	-	1375	-
	112 M								130	1349	-	1344	-			1386	-	1381	-
	132 S								145	1376	-	1371	-			1413	-	1413	-
	132 M								145	1467	-	1462	-			1498	-	1498	-
	160 M								170	1528	1744	-	-			1569	1831	-	-
	160 L								170	1572	1788	-	-			1613	1875	-	-
180 M	185	1589	1810	-	-	210	590	1635	1897	-	-								
B4..6	100 LD	1000	1300	450	515	715	250	185	115	-	-	1418	-	170	470	-	-	1455	-
	112 M								130	1429	-	1424	-			1466	-	1461	-
	132 S								145	1456	-	1451	-			1493	-	1493	-
	132 M								145	1547	-	1542	-			1578	-	1578	-
	160 M								170	1626	1824	-	-			1649	1911	-	-
	160 L								170	1652	1868	-	-			1693	1955	-	-
180 M	185	1669	1890	-	-	210	590	1715	1977	-	-								
B4..7	132 S	1050	1350	540	630	880	250	215	145	-	-	1536	-	170	470	-	-	1568	-
	132 M								170	1637	-	1627	-			1670	-	1653	-
	160 M								170	1698	1899	1688	1899			1724	1986	1724	1986
	160 L								170	1742	1943	1732	1943			1768	2030	1768	2030
	180 M								185	1759	1965	-	-			1790	2052	-	-
	180 L								185	1835	2003	-	-			1886	2090	-	-
200 L	215	1917	2085	-	-	210	590	1968	2172	-	-								
B4..8	132 S	1100	1400	540	630	880	310	215	145	-	-	1641	-	170	470	-	-	1673	-
	132 M								170	1742	-	1732	-			1775	-	1758	-
	160 M								170	1803	2004	1793	2004			1829	2091	1829	2091
	160 L								170	1847	2048	1837	2048			1873	2135	1873	2135
	180 M								185	1864	2070	-	-			1895	2157	-	-
	180 L								185	1940	2108	-	-			1991	2195	-	-
200 L	215	2022	2190	-	-	210	590	2073	2277	-	-								
B4..9	132 M	1250	1500	630	720	970	300	260	145	-	-	1792	-	170	470	-	-	1818	-
	160 M								170	-	-	1853	2064			-	-	1889	2151
	160 L								170	1897	2118	1897	2108			1938	2195	1933	2195
	180 M								185	1914	2140	1914	2130			1955	2217	1955	2217
	180 L								185	1990	2178	1990	2168			2051	2255	2051	2255
	200 L								215	2072	2260	-	-			2133	2337	-	-
	225 S								240	2118	2282	-	-			2181	2359	-	-
	225 M								240	2143	2307	-	-			2206	2384	-	-
	250 M								305	2229	2451	-	-			2292	2533	-	-
B4..10	132 M	1300	1550	630	720	970	350	260	145	-	-	1892	-	170	470	-	-	1918	-
	160 M								170	-	-	1953	2164			-	-	1989	2251
	160 L								170	1997	2218	1997	2208			2038	2295	2033	2295
	180 M								185	2014	2240	2014	2230			2055	2317	2055	2317
	180 L								185	2090	2278	2090	2268			2151	2355	2151	2355
	200 L								215	2172	2360	-	-			2233	2437	-	-
	225 S								240	2218	2382	-	-			2281	2459	-	-
	225 M								240	2243	2407	-	-			2306	2484	-	-
	250 M								305	2329	2551	-	-			2392	2633	-	-
B4..11	160 L	1450	1650	740	880	1280	345	270	170	-	-	2132	2333	170	470	-	-	2153	2410
	180 M								185	-	-	2149	2355			-	-	2170	2432
	180 L								185	2245	2413	2225	2393			2271	2470	2266	2470
	200 L								215	2227	2495	2307	2475			2353	2552	2348	2552
	225 S								240	2343	2517	2332	2497			2396	2574	2395	2574
	225 M								265	2368	2542	-	-			2421	2599	-	-
	250 M								265	2455	2686	-	-			2508	2748	-	-
	280 S								300	2557	2760	-	-			2614	2822	-	-
	280 M								300	2608	2811	-	-			2665	2873	-	-
B4..12	160 L	1500	1700	740	880	1280	430	270	170	-	-	2287	2488	170	470	-	-	2308	2565
	180 M								185	-	-	2306	2510			-	-	2325	2587
	180 L								215	2400	2568	2380	2548			2426	2625	2421	2625
	200 L								215	2482	2650	2462	2630			2508	2707	2503	2707
	225 S								240	2498	2672	2487	2652			2551	2729	2550	2729
	225 M								265	2523	2697	-	-			2576	2754	-	-
	250 M								265	2610	2841	-	-			2663	2903	-	-
	280 S								300	2712	2915	-	-			2769	2977	-	-
	280 M								300	2763	2966	-	-			2820	3028	-	-

1) auf Anfrage

2) l<sub>2</sub>, l<sub>2</sub><sup>\*</sup>, l<sub>3</sub>, l<sub>3</sub><sup>\*</sup> für Loher-Normmotoren  
l<sub>2</sub><sup>\*</sup> für Getriebe mit Lüfter. Getriebe mit Lüfter  
und Trommelbremse auf Anfrage.

4) f<sub>A</sub> = Anfahrfaktor

5) Für f<sub>A</sub> = 2, für f<sub>A</sub> = 1.5 ab Motorgröße 225 S;  
f<sub>A</sub> = 1.5 bis Motorgröße 200 L:  
b<sub>3</sub> = 260 mm, b<sub>4</sub> = 610 mm

6) e<sub>1</sub>-Maß für FLUDEX-Kupplung ohne Vorkammer  
(f<sub>A</sub> = 2); FLUDEX-Kupplung ohne Vorkammer  
mit Trommelbremse (f<sub>A</sub> = 2);  
e<sub>2</sub>-Maß für FLUDEX-Kupplung mit Vorkammer  
(f<sub>A</sub> = 1.5); FLUDEX-Kupplung mit Vorkammer  
und Trommelbremse (f<sub>A</sub> = 1.5);

Gewicht der Getriebeschwinge auf Anfrage

1) On request

2) l<sub>2</sub>, l<sub>2</sub><sup>\*</sup>, l<sub>3</sub>, l<sub>3</sub><sup>\*</sup> for Loher standard motors  
l<sub>2</sub><sup>\*</sup> for gear units with fan. Gear units with fan  
and drum brake on request.

4) f<sub>A</sub> = starting factor

5) For f<sub>A</sub> = 2; for f<sub>A</sub> = 1.5 from motor size 225 S up;  
f<sub>A</sub> = 1.5 up to motor size 200 L:  
b<sub>3</sub> = 260 mm, b<sub>4</sub> = 610 mm

6) e<sub>1</sub> dimension for FLUDEX coupling without delay  
chamber (f<sub>A</sub> = 2); FLUDEX coupling without  
delay chamber with drum brake (f<sub>A</sub> = 2);  
e<sub>2</sub> dimension for FLUDEX coupling with delay  
chamber (f<sub>A</sub> = 1.5); FLUDEX coupling with delay  
chamber and drum brake (f<sub>A</sub> = 1.5);

Weight of gear unit swing-base on request

1) sur demande

2) l<sub>2</sub>, l<sub>2</sub><sup>\*</sup>, l<sub>3</sub>, l<sub>3</sub><sup>\*</sup> pour moteurs standard Loher  
l<sub>2</sub><sup>\*</sup> pour réducteurs avec ventilateurs, réducteur  
avec ventilateur et frein sur demande.

4) f<sub>A</sub> = facteur de démarrage

5) Pour f<sub>A</sub> = 2, pour f<sub>A</sub> = 1.5 à partir de la taille 225 S;  
f<sub>A</sub> = 1.5 jusqu'à la taille 200 L:  
b<sub>3</sub> = 260 mm, b<sub>4</sub> = 610 mm

6) Cote e<sub>1</sub> pour coupleur FLUDEX sans chambre de  
retardement (f<sub>A</sub> = 2); Coupleur FLUDEX sans chambre  
de retardement avec frein à tambour (f<sub>A</sub> = 2);  
Cote e<sub>2</sub> pour coupleur FLUDEX avec chambre de  
retardement (f<sub>A</sub> = 1.5); Coupleur FLUDEX avec chambre  
de retardement et frein à tambour (f<sub>A</sub> = 1.5);

Poids du châssis supports sur demande

## Zahnradgetriebe

Getriebschwingen mit  
FLUDEX-Strömungskupplungen  
Bauarten B3, B4  
Größen 13 - 18

## Gear Units

Gear Unit Swing-bases  
With FLUDEX Fluid Couplings  
Types B3, B4  
Sizes 13 - 18

## Réducteurs à engrenages

Châssis supports avec coupleurs  
hydrauliques FLUDEX  
Types B3, B4  
Tailles 13 - 18

K20/013



Tabelle / Table / Tableau 12

Größe Size Taille	Buchse Bush Douille															Gewicht / Weight / Poids	
		m	n	g	d <sub>3</sub>	A	B	d <sub>5</sub>	F	G	H <sub>1</sub>	H <sub>2</sub>	H <sub>3</sub>	l	s <sub>1</sub>	Stützbock Pedestal Chappe d'ancrage	Drehmomentstütze Torque support Bras de réaction
		mm	mm	mm	mm	mm	mm	mm	mm	mm	mm	mm	mm	mm	mm	kg	kg
13 - 14	772	260	130	∅ 19	19	320	200	100	195	180	400	140	230	120	25	50	82
15 - 18	805	320	240	∅ 24	24	400	300	124	320	240	500	175	285	230	30	95	220

### Zahnradgetriebe

Getriebeschwinge mit  
FLUDEX-Strömungskupplungen  
Bauart B3  
Größen 13 - 18

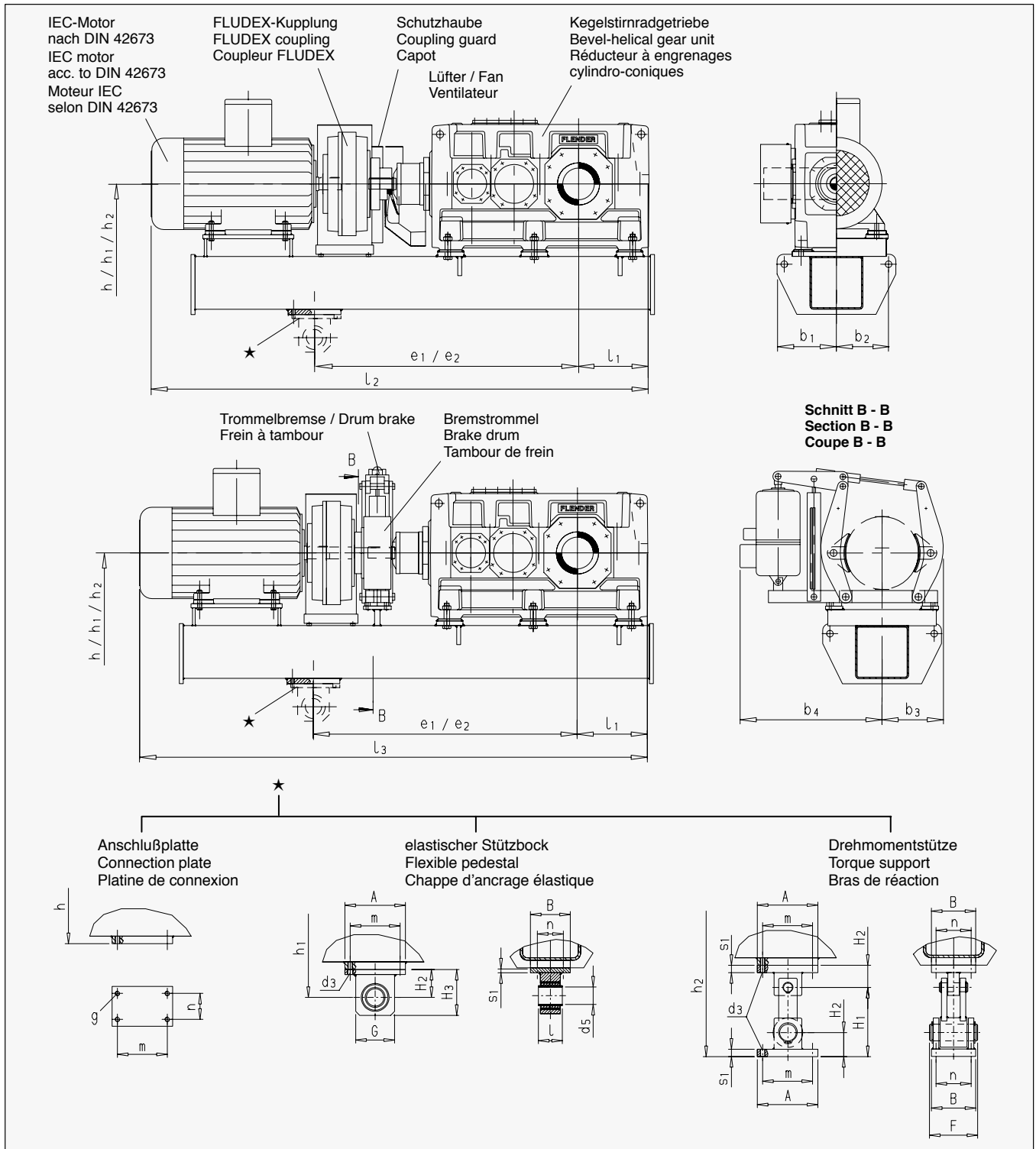
### Gear Units

Gear Unit Swing-bases  
With FLUDEX Fluid Couplings  
Type B3  
Sizes 13 - 18

### Réducteurs à engrenages

Châssis supports avec coupleurs  
hydrauliques FLUDEX  
Type B3  
Tailles 13 - 18

K20/013

Tabelle / Table / Tableau 13																							
Bauart Größe Type Size Type Taille	IEC-Motor nach DIN 42673 IEC motor acc. to DIN 42673 Moteur IEC selon DIN 42673	FLUDEX-Kupplung FLUDEX coupling Coupleur FLUDEX										FLUDEX-Kupplung mit Trommelbremse FLUDEX coupling with drum brake Coupleur FLUDEX avec frein à tambour											
		e <sub>1</sub> <sup>6)</sup>	e <sub>2</sub> <sup>6)</sup>	h	h <sub>1</sub>	h <sub>2</sub>	l <sub>1</sub>	b <sub>1</sub>	b <sub>2</sub>	i <sub>N</sub> = 12.5 - 45		i <sub>N</sub> = 50 - 71		b <sub>3</sub> <sup>5)</sup>	b <sub>4</sub> <sup>5)</sup>	i <sub>N</sub> = 12.5 - 45		i <sub>N</sub> = 50 - 71					
										i <sub>N</sub> = 16 - 56		i <sub>N</sub> = 63 - 90				i <sub>N</sub> = 16 - 56		i <sub>N</sub> = 63 - 90					
										i <sub>N</sub> = 14 - 50		i <sub>N</sub> = 56 - 80				i <sub>N</sub> = 14 - 50		i <sub>N</sub> = 56 - 80					
f <sub>A</sub> = 2 <sup>4)</sup>		f <sub>A</sub> = 1.5 <sup>4)</sup>		f <sub>A</sub> = 2 <sup>4)</sup>		f <sub>A</sub> = 1.5 <sup>4)</sup>		f <sub>A</sub> = 2 <sup>4)</sup>		f <sub>A</sub> = 1.5 <sup>4)</sup>		f <sub>A</sub> = 2 <sup>4)</sup>		f <sub>A</sub> = 1.5 <sup>4)</sup>									
mm																							
B3 .. 13	280 M	1900	2150	800	940	1340	405	345	300	-	-	-	-	2823	2823	3026	3026	260	665	-	-	2862	3070
	315 SB								-	-	-	-	2974	2994	3189	3189	310	765	-	-	3027	3248	
	315 MB								3050	3050	3265	3265	3025	3045	3240	3240	310	765	3093	3314	3078	3299	
	315 MD								3050	3050	3265	3265	3025	3045	3240	3240	310	765	3093	3314	3078	3299	
	315 LB								3205	3205	3444	3444	3180	3200	3419	3419	310	765	3272	3527	3272	3527	
	355 MB								3274	3274	3513	3513	-	-	-	-	385	840	3341	3596	-	-	
355 LB	3344	3344	3583	3583	-	-	-	-	385	840	3411	3666	-	-									
B3 .. 14	280 M	1900	2150	800	940	1340	475	345	300	-	-	-	-	2963	2963	3166	3166	260	665	-	-	3002	3210
	315 SB								-	-	-	-	3114	3134	3329	3329	310	765	-	-	3167	3388	
	315 MB								3190	3190	3405	3405	3165	3185	3380	3380	310	765	3233	3454	3218	3439	
	315 MD								3190	3190	3405	3405	3165	3185	3380	3380	310	765	3233	3454	3218	3439	
	315 LB								3345	3345	3584	3584	3320	3340	3559	3559	310	765	3412	3667	3412	3667	
	355 MB								3414	3414	3653	3653	-	-	-	-	385	840	3481	3736	-	-	
355 LB	3484	3484	3723	3723	-	-	-	-	385	840	3551	3806	-	-									
B3 .. 15	315 MB	2200	2450	975	1150	1650	485	345	330	-	-	-	-	3347	3367	3562	3562	310	765	-	-	3400	3621
	315 MD								-	-	-	-	3347	3367	2562	2562	310	765	-	-	3400	3621	
	315 LB								-	-	-	-	3502	3522	3741	3741	310	765	-	-	3594	3849	
	355 MB								3596	3596	3835	3835	3571	3591	3810	3810	385	840	3663	3918	3663	3918	
	355 LB								3666	3666	3905	3905	3641	3661	3880	3880	385	840	3733	3988	3733	3988	
	315 MD								-	-	-	-	3438	3458	3653	3653	310	765	-	-	3491	3712	
315 LB	-	-	-	-	3438	3458	3653	3653	310	765	-	-	3491	3712									
355 MB	3687	3687	3926	3926	3662	3682	3901	3901	385	840	3754	4009	3754	4009									
355 LB	3757	3757	3996	3996	3732	3752	3971	3971	385	840	3824	4079	3824	4079									
B3 .. 16	315 MB	2200	2450	975	1150	1650	530	345	330	-	-	-	-	3765	3765	4004	4004	385	840	-	-	3827	4082
	315 MD								-	-	-	-	3834	3834	4073	4073	385	840	-	-	3896	4151	
	315 LB								-	-	-	-	3904	3904	4143	4143	385	840	3981	4236	3966	4221	
	355 MB								3939	3939	4178	4178	3904	3904	4143	4143	385	840	3981	4236	3966	4221	
	355 LB								4059	4059	4298	4298	4024	4024	4263	4263	385	840	4101	4356	4086	4341	
	315 LB								-	-	-	-	3885	3885	4124	4124	385	840	-	-	3947	4202	
355 MB	-	-	-	-	3954	3954	4193	4193	385	840	-	-	4016	4271									
355 LB	4059	4059	4298	4298	4024	4024	4263	4263	385	840	4101	4356	4086	4341									

### Bauart B4, Größen 13 - 14

### Type B4, Sizes 13 - 14

### Type B4, Tailles 13 - 14

Tabelle / Table / Tableau 14																			
Bauart Größe Type Size Type Taille	IEC-Motor nach DIN 42673 IEC motor acc. to DIN 42673 Moteur IEC selon DIN 42673	FLUDEX-Kupplung FLUDEX coupling Coupleur FLUDEX										FLUDEX-Kupplung mit Trommelbremse FLUDEX coupling with drum brake Coupleur FLUDEX avec frein à tambour							
		e <sub>1</sub> <sup>6)</sup>	e <sub>2</sub> <sup>6)</sup>	h	h <sub>1</sub>	h <sub>2</sub>	l <sub>1</sub>	b <sub>1</sub>	b <sub>2</sub>	i <sub>N</sub> = 80 - 180		i <sub>N</sub> = 200 - 315		b <sub>3</sub> <sup>5)</sup>	b <sub>4</sub> <sup>5)</sup>	i <sub>N</sub> = 80 - 180		i <sub>N</sub> = 200 - 315	
										i <sub>N</sub> = 100 - 224		i <sub>N</sub> = 250 - 400				i <sub>N</sub> = 100 - 224		i <sub>N</sub> = 250 - 400	
										i <sub>N</sub> = 90 - 200		i <sub>N</sub> = 224 - 355				i <sub>N</sub> = 90 - 200		i <sub>N</sub> = 224 - 355	
f <sub>A</sub> = 2 <sup>4)</sup>		f <sub>A</sub> = 1.5 <sup>4)</sup>		f <sub>A</sub> = 2 <sup>4)</sup>		f <sub>A</sub> = 1.5 <sup>4)</sup>		f <sub>A</sub> = 2 <sup>4)</sup>		f <sub>A</sub> = 1.5 <sup>4)</sup>		f <sub>A</sub> = 2 <sup>4)</sup>		f <sub>A</sub> = 1.5 <sup>4)</sup>					
mm																			
B4 .. 13	180 M	1700	1900	800	940	1340	405	345	185	-	-	2389	2595	210	590	-	-	2395	2652
	180 L								-	-	2465	2633	210	590	-	-	2491	2690	
	200 L								-	-	2547	2715	210	590	-	-	2573	2772	
	225 S								2572	2747	2562	2737	260	665	2615	2794	2615	2794	
	225 M								2597	2772	2587	2762	260	665	2640	2819	2640	2819	
	250 M								2684	2916	2674	2906	260	665	2727	2968	2727	2968	
	280 S								2787	2990	-	-	260	665	2834	3042	-	-	
	280 M								2838	3041	-	-	260	665	2885	3093	-	-	
	315 SB								3004	3204	-	-	310	765	3072	3293	-	-	
	315 MB								3055	3255	-	-	310	765	3123	3344	-	-	
B4 .. 14	180 M	1700	1900	800	940	1340	475	345	185	-	-	2529	2735	210	590	-	-	2535	2792
	180 L								-	-	2605	2773	210	590	-	-	2631	2830	
	200 L								-	-	2687	2855	210	590	-	-	2713	2912	
	225 S								2712	2887	2702	2877	260	665	2755	2934	2755	2934	
	225 M								2737	2912	2727	2902	260	665	2780	2959	2780	2959	
	250 M								2824	3056	2814	3046	260	665	2867	3108	2867	3108	
	280 S								2927	3130	-	-	260	665	2974	3182	-	-	
	280 M								2978	3181	-	-	260	665	3025	3233	-	-	
	315 SB								3114	3344	-	-	310	765	3212	3433	-	-	
	315 MB								3195	3395	-	-	310	765	3263	3484	-	-	

# Zahnradgetriebe

Getriebschwingen mit  
FLUDEX-Strömungskupplungen  
Bauart B4  
Größen 15 - 18

# Gear Units

Gear Unit Swing-bases  
With FLUDEX Fluid Couplings  
Type B4  
Sizes 15 - 18

# Réducteurs à engrenages

Châssis supports avec coupleurs  
hydrauliques FLUDEX  
Type B4  
Tailles 15 - 18

K20/013

Tabelle / Table / Tableau 14

Bauart Größe Type Size Type Taille	IEC-Motor nach DIN 42673 IEC motor acc. to DIN 42673 Moteur IEC selon DIN 42673	FLUDEX-Kupplung FLUDEX coupling Coupleur FLUDEX										FLUDEX-Kupplung mit Trommelbremse FLUDEX coupling with drum brake Coupleur FLUDEX avec frein à tambour													
		$e_1$ 6)		$e_2$ 6)		h		$h_1$		$h_2$		$l_1$		$b_1$		$b_2$		$i_N = 80 - 180$		$i_N = 200 - 315$		$i_N = 80 - 180$		$i_N = 200 - 315$	
		$l_2$ 2)		$l_2$ 2)		$l_2$ 2)		$l_2$ 2)		$l_2$ 2)		$l_2$ 2)		$l_2$ 2)		$l_2$ 2)		$l_2$ 2)		$l_2$ 2)		$l_2$ 2)		$l_2$ 2)	
B4 .. 15	200 L	2000	2200	975	1150	1650	485	345	215	—	—	2869	3037	210	590	—	—	2895	3084	260	665	—	—	2927	3106
	225 S								240	—	—	2884	3059	—	—	2952	3131	—	—	2952	3131				
	225 M								265	3021	3253	2996	3228	—	—	3039	3280	—	—	3039	3280				
	250 M								300	3124	3327	3099	3302	—	—	3146	3354	—	—	3146	3354				
	280 S									3175	3378	3150	3353	—	—	3197	3405	—	—	3197	3405				
	280 M									330	3326	3541	—	—	—	—	—	—	—	—	—	—			
	315 SB								3377		3592	—	—	—	—	—	—	—	—	—	—				
	315 MB								3377		3592	—	—	—	—	—	—	—	—	—	—				
	315 MD								385	3532	3771	—	—	—	—	—	—	—	—	—	—				
315 LB	3532	3771	—	—	—	—	—	—		—	—	—	—												
B4 .. 16	200 L	2000	2200	975	1150	1650	530	345	215	—	—	2960	3128	210	590	—	—	2986	3175	260	665	—	—	3018	3197
	225 S								240	—	—	2975	3150	—	—	3043	3222	—	—	3043	3222				
	225 M								265	3112	3344	3087	3319	—	—	3130	3371	—	—	3130	3371				
	250 M								300	3215	3418	3190	3393	—	—	3237	3445	—	—	3237	3445				
	280 S									3266	3469	3241	3444	—	—	3288	3496	—	—	3288	3496				
	280 M									330	3417	3632	—	—	—	—	—	—	—	—	—				
	315 SB								3468		3683	—	—	—	—	—	—	—	—	—					
	315 MB								3468		3683	—	—	—	—	—	—	—	—	—					
	315 MD								385	3623	3862	—	—	—	—	—	—	—	—	—					
315 LB	3623	3862	—	—	—	—	—	—		—	—	—													
B4 .. 17	225 M	2200	2400	1025	1200	1700	525	500	240	—	—	2997	3172	260	665	—	—	3040	3219	310	765	—	—	3040	3219
	250 M								265	—	—	3084	3316			—	—	3127	3368			—	—	3127	3368
	280 S								300	3212	3415	3187	3390			—	—	3234	3442			—	—	3234	3442
	280 M									3263	3466	3238	3441	—	—	3285	3493	—	—	3285	3493				
	315 SB									3414	3629	3404	3604	—	—	3472	3693	—	—	3472	3693				
	315 MB								330	3465	3680	—	—	—	—	—	—	—	—	—					
	315 MD									3465	3680	—	—	—	—	—	—	—	—	—					
	315 LB									3620	3859	—	—	—	—	—	—	—	—	—					
	355 MB								385	3689	3928	—	—	—	—	—	—	—	—	—					
355 LB	3759	3998	—	—	—	—	—	—		—	—	—													
B4 .. 18	225 M	2200	2400	1025	1200	1700	585	500	240	—	—	3117	3292	260	665	—	—	3160	3339	310	765	—	—	3160	3339
	250 M								265	—	—	3204	3436			—	—	3247	3488			—	—	3247	3488
	280 S								300	3332	3535	3307	3510			—	—	3354	3562			—	—	3354	3562
	280 M									3383	3586	3358	3561	—	—	3405	3613	—	—	3405	3613				
	315 SB									3534	3749	3524	3724	—	—	3592	3813	—	—	3592	3813				
	315 MB								330	3585	3800	—	—	—	—	—	—	—	—	—					
	315 MD									3585	3800	—	—	—	—	—	—	—	—	—					
	315 LB									3740	3979	—	—	—	—	—	—	—	—	—					
	355 MB								385	3809	4048	—	—	—	—	—	—	—	—	—					
355 LB	3879	4118	—	—	—	—	—	—		—	—	—													

1) auf Anfrage

2)  $l_2$ ,  $l_2^*$ ,  $l_3$ ,  $l_3^*$  für Loher-Normmotoren  
 $l_2^*$  für Getriebe mit Lüfter.  
Getriebe mit Lüfter und Trommelbremse auf Anfrage.

4)  $f_A$  = Anfahrfaktor

5) Für  $f_A = 2$ , für  $f_A = 1.5$  ab Motorgröße 225 S;  
 $f_A = 1.5$  bis Motorgröße 200 L:  
 $b_3 = 260$  mm,  $b_4 = 610$  mm

6)  $e_1$ -Maß für FLUDEX-Kupplung ohne Vorkammer ( $f_A = 2$ );  
FLUDEX-Kupplung ohne Vorkammer mit Trommelbremse ( $f_A = 2$ );  
 $e_2$ -Maß für FLUDEX-Kupplung mit Vorkammer ( $f_A = 1.5$ );  
FLUDEX-Kupplung mit Vorkammer und Trommelbremse ( $f_A = 1.5$ );

Gewicht der Getriebschwinge auf Anfrage

1) On request

2)  $l_2$ ,  $l_2^*$ ,  $l_3$ ,  $l_3^*$  for Loher standard motors  
 $l_2^*$  for gear units with fan.  
Gear units with fan and drum brake on request.

4)  $f_A$  = starting factor

5) For  $f_A = 2$ ; for  $f_A = 1.5$  from motor size 225 S up;  
 $f_A = 1.5$  up to motor size 200 L:  
 $b_3 = 260$  mm,  $b_4 = 610$  mm

6)  $e_1$  dimension for FLUDEX coupling without delay chamber ( $f_A = 2$ );  
FLUDEX coupling without delay chamber with drum brake ( $f_A = 2$ );  
 $e_2$  dimension for FLUDEX coupling with delay chamber ( $f_A = 1.5$ );  
FLUDEX coupling with delay chamber and drum brake ( $f_A = 1.5$ );

Weight of gear unit swing-base on request

1) sur demande

2)  $l_2$ ,  $l_2^*$ ,  $l_3$ ,  $l_3^*$  pour moteurs standard Loher  
 $l_2^*$  pour réducteurs avec ventilateurs, réducteur avec ventilateur et frein sur demande.

4)  $f_A$  = facteur de démarrage

5) Pour  $f_A = 2$ , pour  $f_A = 1.5$  à partir de la taille 225 S;  
 $f_A = 1.5$  jusqu'à la taille 200 L:  
 $b_3 = 260$  mm,  $b_4 = 610$  mm

6) Cote  $e_1$  pour coupleur FLUDEX sans chambre de retardement ( $f_A = 2$ );  
Coupleur FLUDEX sans chambre de retardement avec frein à tambour ( $f_A = 2$ );  
Cote  $e_2$  pour coupleur FLUDEX avec chambre de retardement ( $f_A = 1.5$ );  
Coupleur FLUDEX avec chambre de retardement et frein à tambour ( $f_A = 1.5$ );

Poids du châssis supports sur demande

**Zahnradgetriebe**  
Sondereinbaulagen

**Gear Units**  
Special Mounting Positions

**Réducteurs à engrenages**  
Positions de montage particulières

Größen 4 - 18

Sizes 4 - 18

Tailles 4 - 18

K20/017

FLENDER-Zahnradgetriebe der Bauarten H2.., H3.., H4.., B2.., B3.. und B4.. sind auch für nachstehende Sondereinbaulagen lieferbar. Die Aufstellung kann z.B. als Aufsteckgetriebe mit Drehmomentstütze oder mittels Fußleisten erfolgen. Zur Ölversorgung ist die Tabelle 2 zu beachten.

FLENDER gear units of types H2.., H3.., H4.., B2.., B3.. and B4.. are also available for the special mounting positions illustrated below. They can be installed, for example, as shaft-mounted gear unit with torque support or by means of base rails. For oil supply, take into account table 2.

Les réducteurs FLENDER type H2.., H3.., H4.., B2.., B3.. et B4.. sont aussi livrables pour les positions de montage particulières ci-dessous. Le positionnement peut par exp. être un montage flottant avec reprise de la réaction sur les pattes du réducteur. Pour la lubrification respecter le tableau 2.

Einbaulage: Welle  $d_1$  nach oben  
Mounting position: Shaft  $d_1$  upward  
Position de montage: arbre  $d_1$  vers le haut

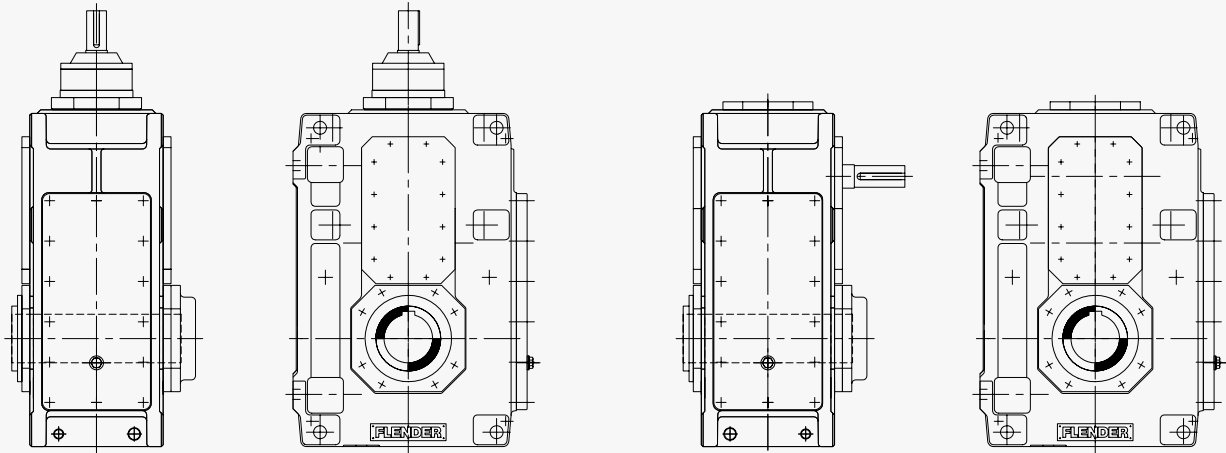

Einbaulage: Welle  $d_1$  nach unten  
Mounting position: Shaft  $d_1$  downward  
Position de montage: arbre  $d_1$  vers le bas

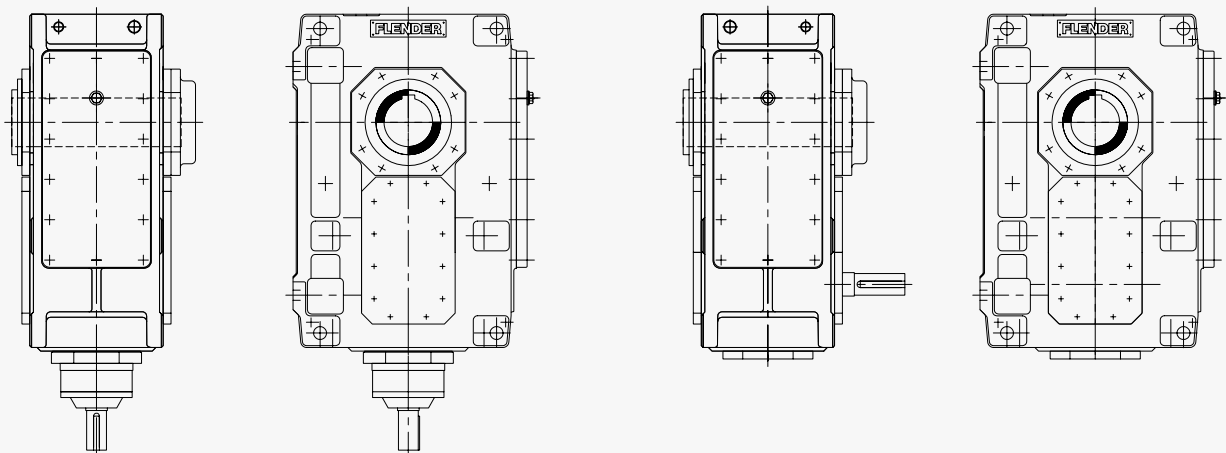

# Zahnradgetriebe

Sondereinbaulagen  
Getriebefußleisten

Größen 4 - 18

# Gear Units

Special Mounting Positions  
Housing Base Rails

Sizes 4 - 18

# Réducteurs à engrenages

Positions de montage  
particulières  
Pattes amovibles

Tailles 4 - 18

K20/017



Tabelle / Table / Tableau 1

Größe Size Taille	H2, H3, H4, B2, B3, B4											H2, H3, H4, B3, B4		B2	
	a	b <sub>1</sub>	c	4 x d	h	m <sub>1</sub>	m <sub>2</sub>	n <sub>1</sub>	n <sub>2</sub>	8 x øs	R <sub>max</sub>	b	m <sub>3</sub>	b	m <sub>3</sub>
4	450	75	28	M 16	255	110	130	20	95	19	160	355	315	-	-
5	510	75	28	M 16	270	110	170	20	125	19	190	395	355	460	420
6					315						220				
7	610	90	35	M 20	325	130	200	25	150	24	230	470	420	550	500
8					385						270				
9	710	110	40	M 24	380	160	230	30	165	28	260	580	520	650	590
10					430						300				
11	860	120	50	M 30	435	190	270	35	205	35	340	660	590	760	690
12					520						380				
13	965	100	60	M 30	430	260	230	37.5	185	35	300	745	665	850	770
14					500						360				
15	1060	110	70	M 36	505	300	190	45	185	42	350	840	750	980	890
16					550						400				
17	1210	125	80	M 42	550	340	250	55	210	48	390	930	820	1125	1015
18					610						440				

Tabelle / Table / Tableau 2

Größe Size Taille	H2	H3	H4	B2	B3	B4
4 - 12	Tauchschrimerung Dip lubrication Lubrification par barbotage	Tauchschrimerung mit Ölausgleichsbehälter Dip lubrication with oil compensating tank Lubrification par barbotage avec vase d'expansion	Tauchschrimerung mit Ölausgleichsbehälter Dip lubrication with oil compensating tank Lubrification par barbotage avec vase d'expansion	Druckschrimerung mit Flanschpumpe Forced lubrication with flanged-on pump Lubrification sous pression avec pompe flasquée	Druckschrimerung mit Flanschpumpe Forced lubrication with flanged-on pump Lubrification sous pression avec pompe flasquée	Druckschrimerung mit Flanschpumpe Forced lubrication with flanged-on pump Lubrification sous pression avec pompe flasquée
13 - 18	Druckschrimerung mit Flanschpumpe Forced lubrication with flanged-on pump Lubrification sous pression avec pompe flasquée	Druckschrimerung mit Flanschpumpe Forced lubrication with flanged-on pump Lubrification sous pression avec pompe flasquée	Druckschrimerung mit Motorpumpe Forced lubrication with motor pump Lubrification sous pression avec motopompe	Druckschrimerung mit Flanschpumpe Forced lubrication with flanged-on pump Lubrification sous pression avec pompe flasquée	Druckschrimerung mit Flanschpumpe Forced lubrication with flanged-on pump Lubrification sous pression avec pompe flasquée	Druckschrimerung mit Motorpumpe Forced lubrication with motor pump Lubrification sous pression avec motopompe

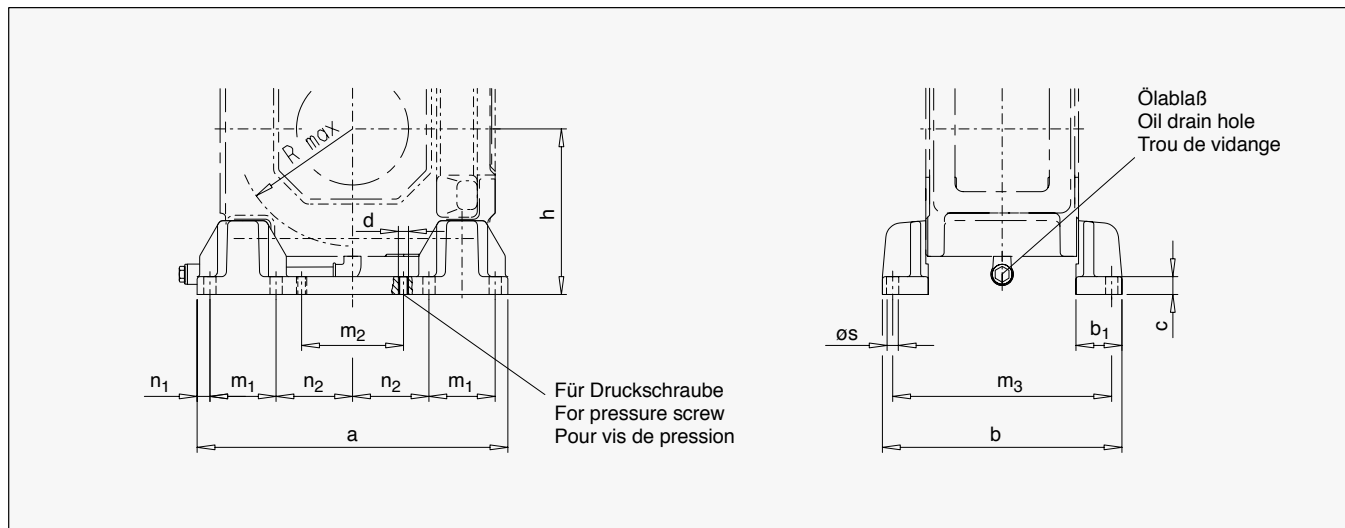
Freiraum für Elemente der Ölversorgung (Pumpe, Rohre, ...) beachten!  
Abmessungen auf Anfrage

Take into account space required for oil supply elements (pump, pipes, etc.)!  
Dimensions on request

Attention! Prévoir l'espace pour les éléments de lubrification (pompe, tuyaux, etc.).  
Dimensions sur demande

## Zahnradgetriebe

Wasserschneckenausführung

Bauart B3SH  
Größen 4 - 12

## Gear Units

For Water Screws

Type B3SH  
Sizes 4 - 12

## Réducteurs à engrenages

Pour vis de relevage des eaux

Type B3SH  
Tailles 4 - 12

K20/015



Tabelle / Table / Tableau 1

Bauart Type	Größe Size Taille	A mm	B mm	G <sub>2</sub> mm	e mm	Ölablaßhahn Oil drain valve Robinet de vidange	R mm
B3SH	4	145	135	140	285	G 3/4	125
	5	160	156.5	165	305	G 3/4	-
	6				345		-
	7	190	185	195	360	G 1	-
	8				420		-
	9	220	220	235	410	G 1	-
	10				460		-
	11	258	260	270	465	G 1 1/4	-
12	550				-		

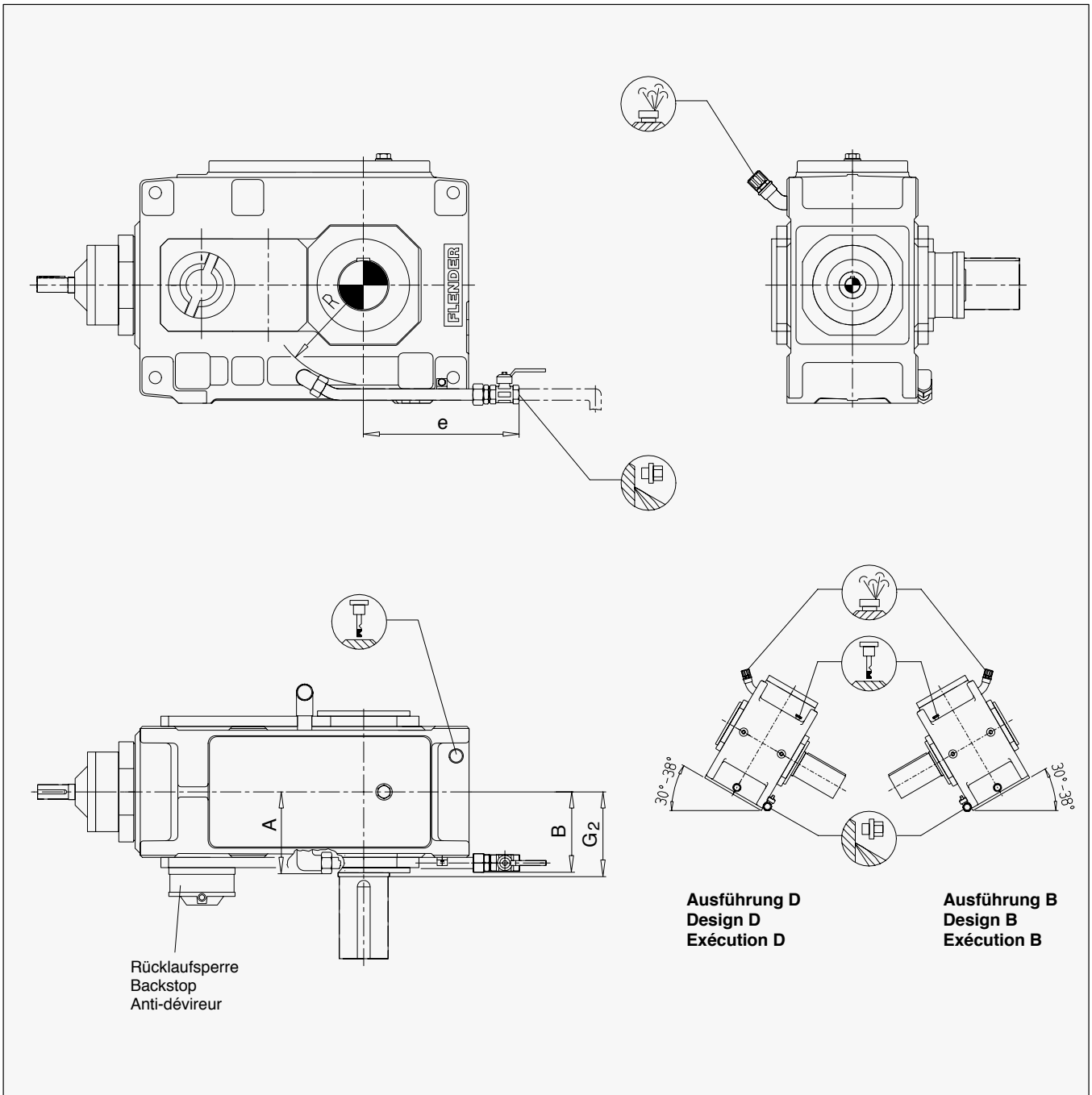

# Zahnradgetriebe

Wasserschneckenausführung

Bauart B3SH

Größen 13 - 18

# Gear Units

For Water Screws

Type B3SH

Sizes 13 - 18

# Réducteurs à engrenages

Pour vis de relevage des eaux

Type B3SH

Tailles 13 - 18

K20/015



Tabelle / Table / Tableau 2

Bauart Type	Größe Size Taille	A mm	B mm	e mm	Ölablaßhahn Oil drain valve Robinet de vidange
<b>B3SH</b>	13	67	135	500	G 1 1/4
	14			570	
	15	80	150	610	G 2
	16			655	
	17	85	180	650	G 2
	18			710	

## Zahnradgetriebe

Motorstühle  
Horizontal  
Bauart H3.H  
Größen 5 - 10

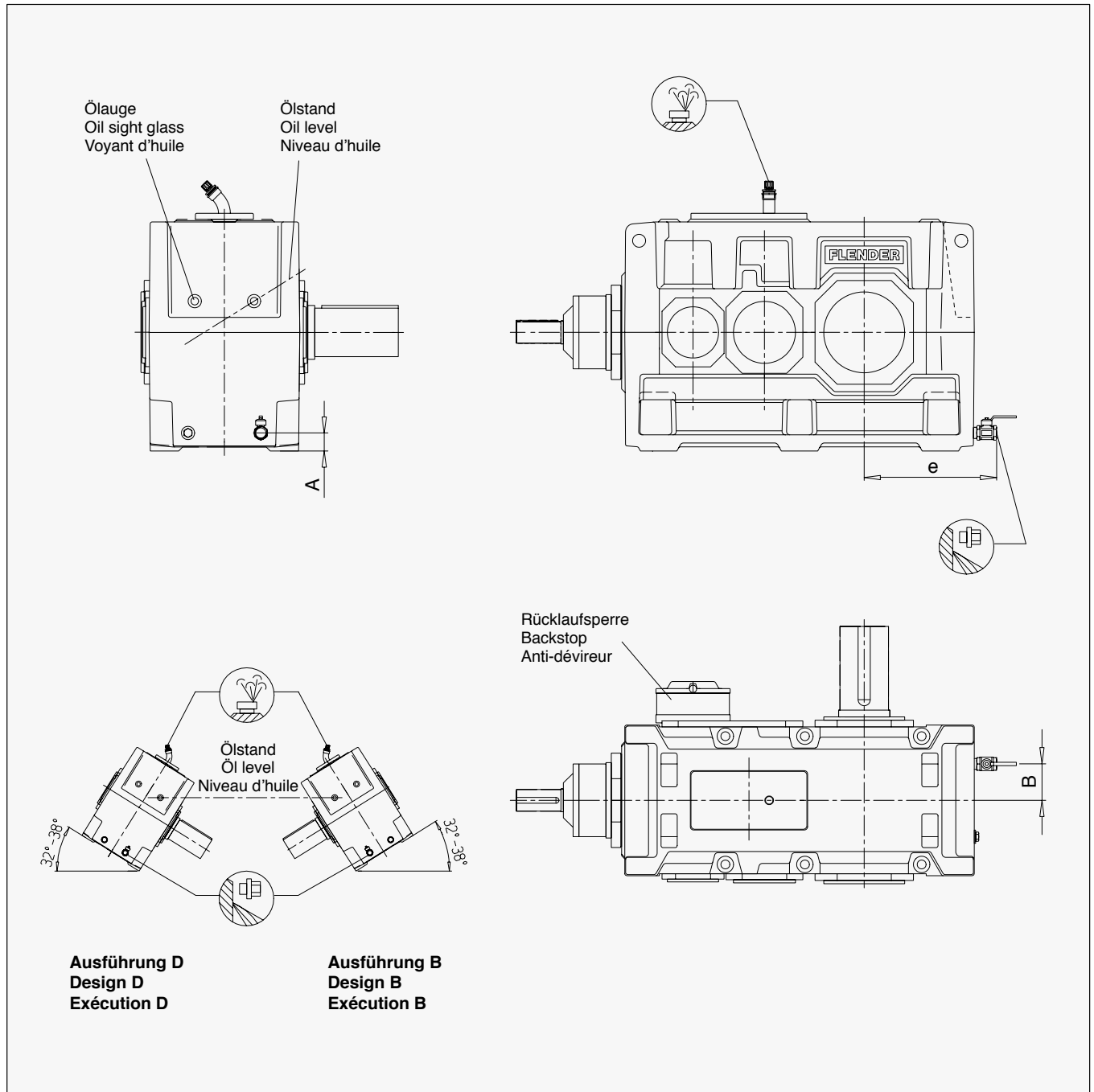
## Gear Units

Motor Brackets  
Horizontal  
Type H3.H  
Sizes 5 - 10

## Réducteurs à engrenages

Châssis support moteur  
Horizontal  
Type H3.H  
Tailles 5 - 10

K20/008



Tabelle / Table / Tableau 1

Bauart Größe Type Size Type Taille	IEC-Motor IEC motor Moteur IEC	i Getriebe Gear unit Réducteur	i Riemetrieb Belt drive Poulies	i Gesamt Total	Riemenscheibe Motorwelle Motor shaft pulley Poulies arbre moteur	Riemen- anzahl No. of belts No. de courroies	b mm	E mm	e <sub>1</sub> mm	e <sub>2</sub> mm	l mm
<b>H3.H 05</b>	132 S	71 - 90	1.25 1.4 1.6 1.8	89 - 162	SPZ 140	2	390	493	180	177	120
	132 M	50 - 90		63 - 162	SPZ 140	3	390	493	180	177	120
	160 M	35.5 - 71		44 - 128	SPZ 180	3	390	530	180	140	120
	160 L	25 - 50		31 - 90	SPA 180	3	390	530	180	140	120
<b>H3.H 06</b>	132 S	90 - 112	1.25 1.4 1.6 1.8	113 - 202	SPZ 140	2	390	493	180	177	120
	132 M	63 - 112		79 - 202	SPZ 140	3	390	493	180	177	120
	160 M	45 - 90		56 - 162	SPZ 180	3	390	530	180	140	120
	160 L	31.5 - 71		39 - 128	SPA 180	3	390	530	180	140	120
<b>H3.H 07</b>	160 M	63 - 90	1.25 1.4 1.6 1.8	79 - 162	SPZ 180	3	460	586	250	224	120
	160 L	50 - 90		63 - 162	SPA 180	3	460	586	250	224	120
	180 M	40 - 71		50 - 128	SPA 250	3	460	626	250	184	120
	180 L	31.5 - 63		39 - 113	SPA 250	3	460	626	250	184	120
	200 L	25 - 45		31 - 54	SPB 280	3	570	680	200	200	150
	225 S	25 - 40		31 - 50	SPB 280	3	570	680	200	200	150
<b>H3.H 08</b>	160 M	80 - 112	1.25 1.4 1.6 1.8	100 - 202	SPZ 180	3	460	586	250	224	120
	160 L	63 - 112		79 - 202	SPA 180	3	460	586	250	224	120
	180 M	50 - 90		63 - 162	SPA 250	3	460	626	250	184	120
	180 L	40 - 80		50 - 144	SPA 250	3	460	626	250	184	120
	200 L	31.5 - 56		39 - 70	SPB 280	3	570	680	200	200	150
	225 S	31.5 - 50		39 - 63	SPB 280	3	570	680	200	200	150
<b>H3.H 09</b>	160 L	80 - 90	1.25 1.4 1.6 1.8	100 - 162	SPA 180	3	460	615	250	235	135
	180 M	71 - 90		89 - 162	SPA 250	3	460	664	250	186	135
	180 L	56 - 90		70 - 162	SPA 250	3	460	664	250	186	135
	200 L	40 - 80		50 - 144	SPB 280	3	570	747	275	203	150
	225 S	31.5 - 63		39 - 113	SPB 280	3	570	750	275	200	150
	225 M	28 - 50		35 - 90	SPB 280	4	570	750	275	200	150
	250 M	25 - 45		31 - 81	SPB 315	4	660	804	305	226	150
<b>H3.H 10</b>	160 L	100; 112	1.25 1.4 1.6 1.8	125 - 202	SPA 180	3	460	615	250	235	135
	180 M	80 - 112		100 - 202	SPA 250	3	460	664	250	186	135
	180 L	71 - 112		89 - 202	SPA 250	3	460	664	250	186	135
	200 L	50 - 100		63 - 180	SPB 280	3	570	747	275	203	150
	225 S	40 - 80		50 - 144	SPB 280	3	570	750	275	200	150
	225 M	31.5 - 63		39 - 113	SPB 280	4	570	750	275	200	150
	250 M	31.5 - 56		39 - 101	SPB 315	4	660	804	305	226	150

## Zahnradgetriebe

Motorstühle  
Horizontal  
Bauart H3.H  
Größen 11 - 18

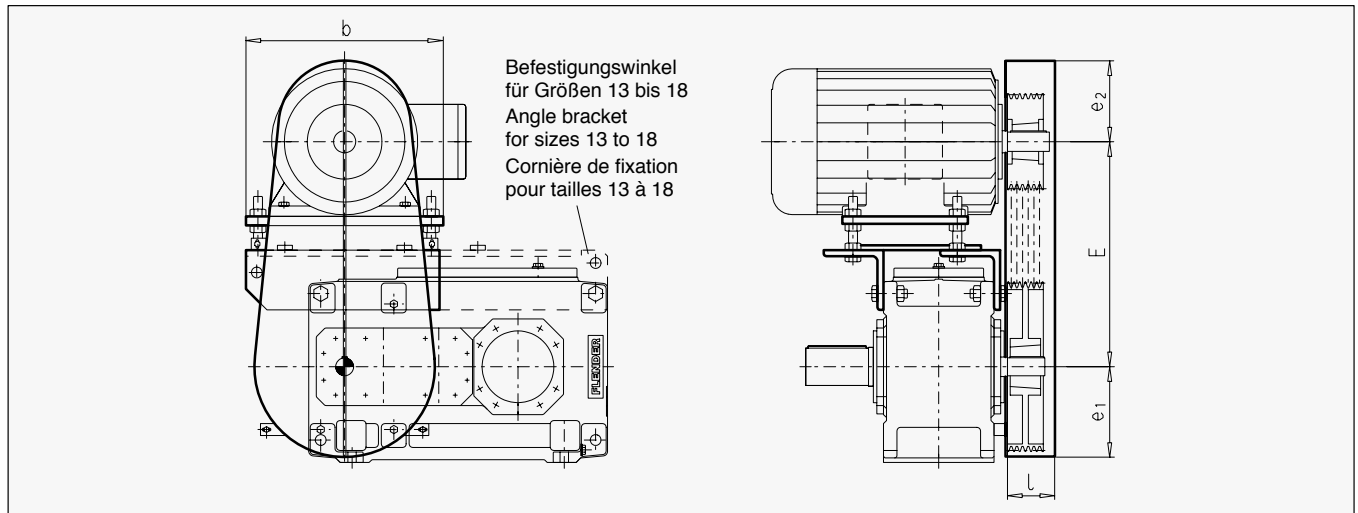
## Gear Units

Motor Brackets  
Horizontal  
Type H3.H  
Sizes 11 - 18

## Réducteurs à engrenages

Châssis support moteur  
Horizontal  
Type H3.H  
Tailles 11 - 18

K20/008

Bauart Größe Type Size Type Taille	IEC-Motor IEC motor Moteur IEC	i Getriebe i Gear unit i Réducteur	i Riemetrieb i Belt drive i Poulies	i Gesamt i Total	Riemenscheibe Motorwelle Motor shaft pulley Poulies arbre moteur	Riemen- anzahl No. of belts No. de courroies	b mm	E mm	e <sub>1</sub> mm	e <sub>2</sub> mm	l mm
<b>H3.H 11</b>	200 L	71 - 90	1.25 1.4 1.6 1.8	89 - 162	SPB 280	3	570	825	275	200	150
	225 S	56 - 90		70 - 162	SPB 280	3	570	825	275	200	150
	225 M	50 - 90		63 - 162	SPB 280	4	570	825	275	200	150
	250 M	40 - 71		50 - 128	SPB 315	4	720	897	305	268	150
	280 S	31.5 - 56		39 - 101	SPB 315	5	720	938	305	227	150
	280 M	25 - 45		31 - 81	SPB 315	6	720	938	305	227	150
	315 S	25 - 35.5		31 - 64	SPC 355	5	810	1001	340	249	180
<b>H3.H 12</b>	200 L	90 - 112	1.25 1.4 1.6 1.8	113 - 202	SPB 280	3	570	825	275	200	150
	225 S	71 - 112		89 - 202	SPB 280	3	570	825	275	200	150
	225 M	63 - 112		79 - 202	SPB 280	4	570	825	275	200	150
	250 M	50 - 90		63 - 162	SPB 315	4	720	897	305	268	150
	280 S	35.5 - 63		44 - 113	SPB 315	5	720	938	305	227	150
	280 M	31.5 - 56		39 - 101	SPB 315	6	720	938	305	227	150
	315 S	31.5 - 45		39 - 81	SPC 355	5	810	1001	340	249	180
<b>H3.H 13</b>	225 M	80; 90	1.25 1.4 1.6 1.8	100 - 162	SPB 280	4	570	881	275	199	175
	250 M	63 - 90		79 - 162	SPB 315	4	720	938	305	227	155
	280 S	45 - 80		56 - 144	SPB 315	5	720	938	305	227	155
	280 M	40 - 71		50 - 128	SPB 315	6	720	938	305	227	155
	315 S	31.5 - 56		39 - 101	SPC 355	5	810	1042	380	268	225
	315 M	22.4 - 50		28 - 90	SPC 355	6	810	1042	380	268	225
<b>H3.H 14</b>	225 M	90 - 112	1.25 1.4 1.6 1.8	113 - 202	SPB 280	4	570	881	275	199	175
	250 M	80 - 112		100 - 202	SPB 315	4	720	938	305	227	155
	280 S	56 - 100		70 - 180	SPB 315	5	720	938	305	227	155
	280 M	45 - 90		56 - 162	SPB 315	6	720	938	305	227	155
	315 S	40 - 71		50 - 128	SPC 355	5	810	1042	380	268	225
	315 M	28 - 63		35 - 113	SPC 355	6	810	1042	380	268	225
<b>H3.H 15</b>	280 S	80; 90	1.25 1.4 1.6 1.8	100 - 162	SPB 315	5	720	980	305	225	215
	280 M	63 - 90		79 - 162	SPB 315	6	720	980	305	225	215
	315 S	50 - 90		63 - 162	SPC 355	5	810	1060	380	270	225
	315 M	45 - 80		56 - 144	SPC 355	6	810	1060	380	270	225
	315 MD <sup>1)</sup>	35.5 - 45		44 - 81	SPC 400	8	810	1060	380	270	225
	315 LB <sup>1)</sup>	22.4 - 45		28 - 81	SPC 400	8	810	1060	380	270	225
<b>H3.H 16</b>	280 S	90; 100	1.25 1.4 1.6 1.8	113 - 180	SPB 315	5	720	980	305	225	215
	280 M	71 - 100		89 - 180	SPB 315	6	720	980	305	225	215
	315 S	56 - 100		70 - 180	SPC 355	5	810	1060	380	270	225
	315 M	50 - 90		63 - 162	SPC 355	6	810	1060	380	270	225
	315 MD <sup>1)</sup>	40 - 50		50 - 90	SPC 400	8	810	1060	380	270	225
	315 LB <sup>1)</sup>	25 - 50		31 - 90	SPC 400	8	810	1060	380	270	225
<b>H3.H 17</b>	280 M	80; 90	1.25 1.4 1.6 1.8	100 - 162	SPB 315	6	720	1072	305	223	215
	315 S	71 - 90		89 - 162	SPC 355	5	810	1117	380	268	225
	315 M	63 - 90		79 - 162	SPC 355	6	810	1117	380	268	225
	315 MD <sup>1)</sup>	50 - 90		63 - 162	SPC 400	8	810	1117	380	268	225
	315 LB <sup>1)</sup>	22.4 - 45		28 - 81	SPC 400	8	810	1117	380	268	225
<b>H3.H 18</b>	280 M	100	1.25 1.4 1.6 1.8	125 - 180	SPB 315	6	720	1072	305	223	215
	315 S	90; 100		113 - 180	SPC 355	5	810	1117	380	268	225
	315 M	71 - 100		89 - 180	SPC 355	6	810	1117	380	268	225
	315 MD <sup>1)</sup>	63 - 100		79 - 180	SPC 400	8	810	1117	380	268	225
	315 LB <sup>1)</sup>	25 - 50		31 - 90	SPC 400	8	810	1117	380	268	225

1) Loher-Baugrößen

1) Loher sizes

1) Tailles Loher

## Zahnradgetriebe

Motorstühle  
Horizontal  
Bauart H4.H  
Größen 7 - 12

## Gear Units

Motor Brackets  
Horizontal  
Type H4.H  
Sizes 7 - 12

## Réducteurs à engrenages

Châssis support moteur  
Horizontal  
Type H4.H  
Tailles 7 - 12

K20/008



Tabelle / Table / Tableau 2

Bauart Größe Type Size Type Taille	IEC-Motor IEC motor Moteur IEC	i Getriebe i Gear unit i Réducteur	i Riemetrieb i Belt drive i Poulies	i Gesamt i Total	Riemenscheibe Motorwelle Motor shaft pulley Poulies arbre moteur	Riemen- anzahl No. of belts No. de courroies	b mm	E mm	e <sub>1</sub> mm	e <sub>2</sub> mm	l mm
<b>H4.H 07</b>	100 LB	315; 355	1.25 1.4 1.6 1.8	394 - 639	SPZ 100	2	310	597	125	123	70
	100 LD	250 - 355		313 - 639	SPZ 100	2	310	597	125	123	70
	112 M	180 - 355		225 - 639	SPZ 112	2	310	613	125	107	70
	132 S	140 - 250		175 - 450	SPZ 140	2	350	632	150	123	90
	132 M	100 - 180		125 - 324	SPZ 140	3	350	632	150	123	90
<b>H4.H 08</b>	100 LB	400; 450	1.25 1.4 1.6 1.8	500 - 810	SPZ 100	2	310	597	125	123	70
	100 LD	315 - 450		394 - 810	SPZ 100	2	310	597	125	123	70
	112 M	224 - 450		280 - 810	SPZ 112	2	310	613	125	107	70
	132 S	180 - 355		225 - 639	SPZ 140	2	350	632	150	123	90
	132 M	125 - 250		156 - 450	SPZ 140	3	350	632	150	123	90
<b>H4.H 09</b>	112 M	315; 355	1.25 1.4 1.6 1.8	394 - 639	SPZ 112	2	390	672	125	108	70
	132 S	224 - 355		280 - 639	SPZ 140	2	390	701	180	154	120
	132 M	160 - 315		200 - 567	SPZ 140	3	390	701	180	154	120
	160 M	112 - 224		140 - 403	SPZ 180	3	390	742	180	143	120
	160 L	100 - 160		125 - 288	SPA 180	3	390	742	180	143	120
<b>H4.H 10</b>	112 M	400; 450	1.25 1.4 1.6 1.8	500 - 810	SPZ 112	2	390	672	125	108	70
	132 S	280 - 450		350 - 810	SPZ 140	2	390	701	180	154	120
	132 M	200 - 400		250 - 720	SPZ 140	3	390	701	180	154	120
	160 M	140 - 280		175 - 504	SPZ 180	3	390	742	180	143	120
	160 L	125 - 180		156 - 324	SPA 180	3	390	742	180	143	120
<b>H4.H 11</b>	132 M	280 - 355	1.25 1.4 1.6 1.8	350 - 639	SPZ 140	3	460	785	150	120	110
	160 M	200 - 355		250 - 639	SPZ 180	3	460	842	250	198	120
	160 L	140 - 280		175 - 504	SPA 180	3	460	842	250	198	120
	180 M	125 - 224		156 - 403	SPA 250	3	460	852	250	188	120
	180 L	100 - 180		125 - 324	SPA 250	3	460	852	250	188	120
	200 L	100 - 140		125 - 252	SPB 280	3	520	923	250	202	120
<b>H4.H 12</b>	132 M	355 - 450	1.25 1.4 1.6 1.8	444 - 810	SPZ 140	3	460	785	150	120	110
	160 M	250 - 450		313 - 810	SPZ 180	3	460	842	250	198	120
	160 L	180 - 355		225 - 639	SPA 180	3	460	842	250	198	120
	180 M	140 - 280		175 - 504	SPA 250	3	460	852	250	188	120
	180 L	125 - 224		156 - 403	SPA 250	3	460	852	250	188	120
	200 L	125 - 180		156 - 324	SPB 280	3	520	923	250	202	120

**Zahnradgetriebe**

Motorstühle  
Horizontal  
Bauart H4.H  
Größen 13 - 18

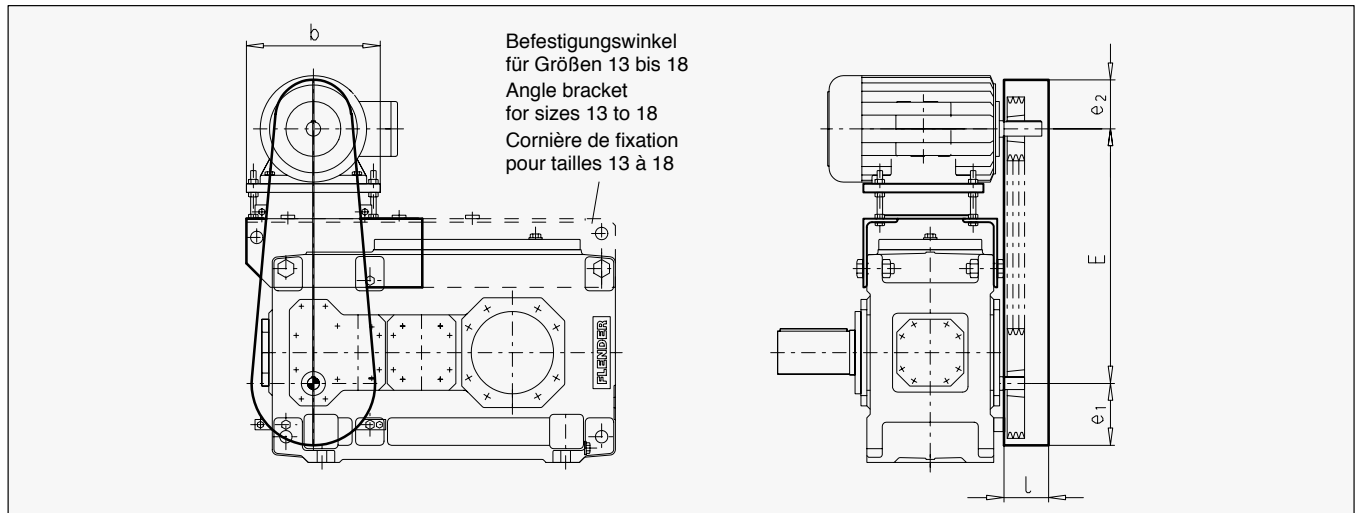
**Gear Units**

Motor Brackets  
Horizontal  
Type H4.H  
Sizes 13 - 18

**Réducteurs à engrenages**

Châssis support moteur  
Horizontal  
Type H4.H  
Tailles 13 - 18

K20/008

Bauart Größe Type Size Type Taille	IEC-Motor IEC motor Moteur IEC	i Getriebe i Gear unit i Réducteur	i Riementrieb i Belt drive i Poulies	i Gesamt i Total	Riemenscheibe Motorwelle Motor shaft pulley Poulies arbre moteur	Riemen- anzahl No. of belts No. de courroies	b mm	E mm	e <sub>1</sub> mm	e <sub>2</sub> mm	l mm
<b>H4.H 13</b>	160 M	315; 355	1.25 1.4 1.6 1.8	394 - 639	SPZ 180	3	460	934	250	166	125
	160 L	224 - 355		280 - 639	SPA 180	3	460	934	250	166	125
	180 M	180 - 355		225 - 639	SPA 250	3	460	914	250	186	125
	180 L	160 - 280		200 - 504	SPA 250	3	460	914	250	186	125
	200 L	112 - 224		140 - 403	SPB 280	3	570	1001	275	214	155
	225 S	100 - 180		125 - 324	SPB 280	3	570	1001	275	214	155
	225 M	100 - 140		125 - 252	SPB 280	4	570	1001	275	214	155
<b>H4.H 14</b>	160 M	400; 450	1.25 1.4 1.6 1.8	500 - 810	SPZ 180	3	460	934	250	166	125
	160 L	280 - 450		350 - 810	SPA 180	3	460	934	250	166	125
	180 M	224 - 450		280 - 810	SPA 250	3	460	914	250	186	125
	180 L	200 - 355		250 - 639	SPA 250	3	460	914	250	186	125
	200 L	140 - 280		175 - 504	SPB 280	3	570	1001	275	214	155
	225 S	125 - 224		156 - 403	SPB 280	3	570	1001	275	214	155
	225 M	125 - 180		156 - 324	SPB 280	4	570	1001	275	214	155
<b>H4.H 15</b>	160 L	355	1.25 1.4 1.6 1.8	444 - 639	SPA 180	3	460	928	250	232	150
	180 M	315; 355		394 - 639	SPA 250	3	460	964	250	196	150
	180 L	250 - 355		313 - 639	SPA 250	3	460	964	250	196	150
	200 L	180 - 355		225 - 639	SPB 280	3	570	1057	275	208	155
	225 S	160 - 280		200 - 504	SPB 280	3	570	1057	275	208	155
	225 M	125 - 250		156 - 450	SPB 280	4	570	1057	275	208	155
	250 M	100 - 200		125 - 360	SPB 315	4	660	1131	305	229	155
<b>H4.H 16</b>	180 M	280 - 400	1.25 1.4 1.6 1.8	350 - 720	SPA 250	3	460	964	250	196	150
	180 L	224 - 400		280 - 720	SPA 250	3	460	964	250	196	150
	200 L	180 - 355		225 - 639	SPB 280	3	570	1057	275	208	155
	225 S	140 - 280		175 - 504	SPB 280	3	570	1057	275	208	155
	225 M	112 - 224		140 - 403	SPB 280	4	570	1057	275	208	155
	250 M	112 - 224		140 - 403	SPB 315	4	660	1131	305	229	155
<b>H4.H 17</b>	180 L	355	1.25 1.4 1.6 1.8	444 - 639	SPA 250	3	520	1047	275	190	125
	200 L	250 - 355		313 - 639	SPB 280	3	520	1098	275	207	125
	225 S	200 - 355		250 - 639	SPB 280	3	660	1157	305	253	155
	225 M	180 - 315		225 - 567	SPB 280	4	660	1157	305	253	155
	250 M	140 - 280		175 - 504	SPB 315	4	660	1181	305	229	155
	280 S	100 - 200		125 - 360	SPB 315	5	720	1231	305	229	155
	280 M	100 - 160		125 - 288	SPB 315	6	720	1231	305	229	155
<b>H4.H 18</b>	200 L	315 - 400	1.25 1.4 1.6 1.8	394 - 720	SPB 280	3	520	1098	275	207	125
	225 S	250 - 400		313 - 720	SPB 280	3	660	1157	305	253	155
	225 M	224 - 400		280 - 720	SPB 280	4	660	1157	305	253	155
	250 M	180 - 355		225 - 639	SPB 315	4	660	1181	305	229	155
	280 S	125 - 250		156 - 450	SPB 315	5	720	1231	305	229	155
	280 M	112 - 200		140 - 360	SPB 315	6	720	1231	305	229	155

## Zahnradgetriebe

Motorstühle  
Horizontal  
Bauart B3.H  
Größen 4 - 10

## Gear Units

Motor Brackets  
Horizontal  
Type B3.H  
Sizes 4 - 10

## Réducteurs à engrenages

Châssis support moteur  
Horizontal  
Type B3.H  
Tailles 4 - 10

K20/008



Tabelle / Table / Tableau 3

Bauart Größe Type / Size Type Taille	IEC-Motor IEC motor Moteur IEC	i Getriebe i Gear unit i Réducteur	i Riemetrieb i Belt drive i Poulies	i Gesamt i Total	Riemenscheibe Motorwelle Poulies arbre moteur	Riemen- anzahl No. of belts No. de courroies	b mm	E mm	e <sub>1</sub> mm	e <sub>2</sub> mm	l mm
<b>B3.H</b> <b>04</b>	112 M	56 - 71	1.25	70 - 127.8	SPZ 112	2	375	421	120	104	85
	132 S	45 - 71		56.3 - 127.8	SPZ 140	2	455	434	180	182	120
	132 M	31.5 - 45		39.4 - 81	SPZ 140	3	455	434	180	182	120
	160 M	20 - 45		25 - 81	SPZ 180	3	455	476	180	140	120
	160 L	31.5; 35.5	1.8	39.4 - 63.9	SPA 180	3	455	476	180	140	120
<b>B3.H</b> <b>05</b>	132 M	45 - 71	1.25	56.3 - 127.8	SPZ 140	3	415	476	180	167	120
	160 M	35.5 - 71		44.4 - 127.8	SPZ 180	3	415	502	180	141	120
	160 L	28 - 50		35 - 90	SPA 180	3	415	502	180	141	120
	180 M	22.4 - 40		28 - 64	SPA 250	3	495	534	220	171	120
	180 L	31.5; 35.5	1.8	39.4 - 56.8	SPA 250	3	495	534	220	171	120
<b>B3.H</b> <b>06</b>	132 M	30 - 90	1.25	37.5 - 162	SPZ 140	3	415	476	180	167	120
	160 M	45 - 90		56.3 - 162	SPZ 180	3	415	502	180	141	120
	160 L	31.5 - 63		39.4 - 113.4	SPA 180	3	415	502	180	141	120
	180 M	28 - 50		35 - 80	SPA 250	3	495	534	220	171	120
	180 L	25 - 45	1.8	31.3 - 72	SPA 250	3	495	534	220	171	120
<b>B3.H</b> <b>07</b>	160 M	63; 71	1.25	78.8 - 127.8	SPZ 180	3	450	553	180	137	120
	160 L	50 - 71		62.5 - 127.8	SPA 180	3	450	553	180	137	120
	180 M	40 - 71		50 - 127.8	SPA 250	3	660	588	273	320	150
	180 L	31.5 - 63		39.4 - 113.4	SPA 250	3	660	588	273	320	150
	200 L	25 - 45		31.3 - 81	SPB 280	3	660	643	273	265	150
	225 S	20 - 40		25 - 72	SPB 280	3	660	713	273	195	150
	225 M	20 - 31.5	1.8	25 - 56.7	SPB 280	4	660	713	273	195	150
<b>B3.H</b> <b>08</b>	160 M	80; 90	1.25	100 - 162	SPZ 180	3	450	553	180	137	120
	160 L	63 - 90		78.8 - 162	SPA 180	3	450	553	180	137	120
	180 M	50 - 90		62.5 - 162	SPA 250	3	660	588	273	320	150
	180 L	40 - 80		50 - 144	SPA 250	3	660	588	273	320	150
	200 L	31.5 - 56		39.4 - 100.8	SPB 280	3	660	643	273	265	150
	225 S	25 - 45		31.3 - 81	SPB 280	3	660	713	273	195	150
	225 M	25 - 40	1.8	31.3 - 72	SPB 280	4	660	713	273	195	150
<b>B3.H</b> <b>09</b>	180 M	63; 71	1.25	78.8 - 127.8	SPA 250	3	550	635	270	273	150
	180 L	56 - 71		70 - 127.8	SPA 250	3	550	635	270	273	150
	200 L	40 - 71		50 - 127.8	SPB 280	3	550	713	270	195	150
	225 S	40 - 53		50 - 113.4	SPB 280	3	550	713	270	195	150
	225 M	28 - 50		35 - 90	SPB 280	4	550	713	270	195	150
	250 M	22.4 - 45		28 - 81	SPB 315	4	730	762	300	269	150
	280 S	20 - 31.5		25 - 56.7	SPB 315	5	730	803	300	228	150
	280 M	20 - 25	1.8	25 - 45	SPB 315	6	730	803	300	228	150
<b>B3.H</b> <b>10</b>	180 M	80; 90	1.25	100 - 162	SPA 250	3	550	635	270	273	150
	180 L	71 - 90		88.8 - 162	SPA 250	3	550	635	270	273	150
	200 L	50 - 90		62.5 - 162	SPB 280	3	550	713	270	195	150
	225 S	40 - 80		50 - 144	SPB 280	3	550	713	270	195	150
	225 M	31.5 - 63		39.4 - 113.4	SPB 280	4	550	713	270	195	150
	250 M	28 - 56		35 - 100.8	SPB 315	4	730	762	300	269	150
	280 S	25 - 40		31.3 - 72	SPB 315	5	730	803	300	228	150
	280 M	25 - 31.5	1.8	31.3 - 56.7	SPB 315	6	730	803	300	228	150

## Zahnradgetriebe

Motorstühle  
Horizontal  
Bauart B3.H  
Größen 11 - 18

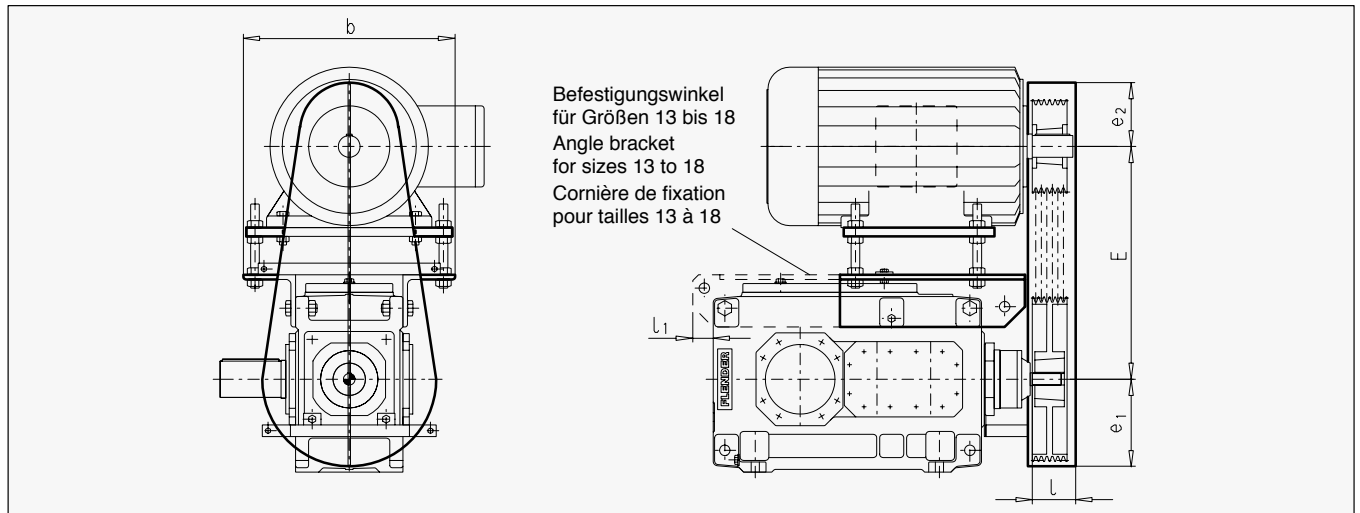
## Gear Units

Motor Brackets  
Horizontal  
Type B3.H  
Sizes 11 - 18

## Réducteurs à engrenages

Châssis support moteur  
Horizontal  
Type B3.H  
Tailles 11 - 18

K20/008

Bauart Größe Type / Size Type Taille	IEC-Motor IEC motor Moteur IEC 1)	i Getriebe Gear unit Réducteur	i Riementrieb Belt drive Poulies	i Gesamt Total	Riemenscheibe Motorwelle Motor shaft pulley Poulies arbre moteur	Riemen- anzahl No. of belts No. de courroies	b mm	E mm	e <sub>1</sub> mm	e <sub>2</sub> mm	l mm	l <sub>1</sub> mm
<b>B3.H 11</b>	225 S	56 - 71	1.25 1.4 1.6 1.8	70 - 127.8	SPB 280	3	630	789	275	200	153	-
	225 M	45 - 71		56.3 - 127.8	SPB 280	4	630	789	275	200	153	
	250 M	40 - 71		50 - 127.8	SPB 315	4	790	854	305	268	158	
	280 S	28 - 56		35 - 100.8	SPB 315	5	790	897	305	225	158	
	280 M	22.4 - 45		28 - 81	SPB 315	6	790	897	305	225	158	
	315 S	20 - 35.5		25 - 63.9	SPC 355	5	830	992	340	250	184	
	315 M	20 - 31.5		25 - 56.7	SPC 355	6	830	992	340	250	184	
315 MD <sup>1)</sup>	20 - 25	25 - 45	SPC 400	8	830	992	340	250	184			
<b>B3.H 12</b>	225 S	71 - 90	1.25 1.4 1.6 1.8	88.8 - 162	SPB 280	3	630	789	275	200	153	-
	225 M	56 - 90		70 - 162	SPB 280	4	630	789	275	200	153	
	250 M	50 - 90		62.5 - 162	SPB 315	4	790	854	305	268	158	
	280 S	35.5 - 63		44.4 - 113.4	SPB 315	5	790	897	305	225	158	
	280 M	31.5 - 56		39.4 - 100.8	SPB 315	6	790	897	305	225	158	
	315 S	25 - 45		31.3 - 81	SPC 355	5	830	992	340	250	184	
	315 M	25 - 40		31.3 - 72	SPC 355	6	830	992	340	250	184	
315 MD <sup>1)</sup>	25 - 31.5	31.3 - 56.7	SPC 400	8	830	992	340	250	184			
<b>B3.H 13</b>	250 M	63; 71	1.25 1.4 1.6 1.8	78.8 - 127.8	SPB 315	4	745	938	320	230	183	100
	280 S	45 - 71		56.3 - 127.8	SPB 315	5	745	938	320	230	183	
	280 M	35.5 - 71		44.4 - 127.8	SPB 315	6	745	938	320	230	183	
	315 S	31.5 - 56		39.4 - 100.8	SPC 355	5	945	1017	390	283	227	
	315 M	25 - 50		31.3 - 90	SPC 355	6	945	1017	390	283	227	
	315 MD <sup>1)</sup>	22.4 - 40		28 - 72	SPC 400	8	945	1017	390	283	227	
	315 LB <sup>1)</sup>	20 - 31.5		25 - 56.7	SPC 400	8	945	1017	390	283	227	
<b>B3.H 14</b>	250 M	80; 90	1.25 1.4 1.6 1.8	100 - 162	SPB 315	4	745	938	320	230	183	100
	280 S	56 - 90		70 - 162	SPB 315	5	745	938	320	230	183	
	280 M	45 - 90		56.3 - 162	SPB 315	6	745	938	320	230	183	
	315 S	40 - 71		50 - 127.8	SPC 355	5	945	1017	390	283	227	
	315 M	31.5 - 63		39.4 - 113.4	SPC 355	6	945	1017	390	283	227	
	315 MD <sup>1)</sup>	28 - 50		35 - 90	SPC 400	8	945	1017	390	283	227	
	315 LB <sup>1)</sup>	25 - 40		31.3 - 72	SPC 400	8	945	1017	390	283	227	
<b>B3.H 15</b>	280 M	63; 71	1.25 1.4 1.6 1.8	78.8 - 127.8	SPB 315	6	827	1031	305	225	180	120
	315 S	50 - 71		62.5 - 127.8	SPC 355	5	827	1042	380	265	226	
	315 M	45 - 71		56.3 - 127.8	SPC 355	6	827	1042	380	265	226	
	315 MD <sup>1)</sup>	35.5 - 63		44.4 - 113.4	SPC 400	8	827	1042	380	265	226	
	315 LB <sup>1)</sup>	28 - 56		35 - 100.8	SPC 400	8	827	1042	380	265	226	
	315 MB <sup>1)</sup>	22.4 - 45		28 - 81	SPC 450	8	1027	1130	425	295	336	
	355 LB <sup>1)</sup>	20 - 31.5		25 - 56.7	SPC 450	8	1027	1130	425	295	336	
<b>B3.H 16</b>	280 M	71; 90	1.25 1.4 1.6 1.8	88.8 - 162	SPB 315	6	827	1031	305	225	180	120
	315 S	56 - 80		70 - 144	SPC 355	5	827	1042	380	265	226	
	315 M	50 - 80		62.5 - 144	SPC 355	6	827	1042	380	265	226	
	315 MD <sup>1)</sup>	40 - 71		50 - 127.8	SPC 400	8	827	1042	380	265	226	
	315 LB <sup>1)</sup>	31.5 - 63		39.4 - 113.4	SPC 400	8	827	1042	380	265	226	
	355 MB <sup>1)</sup>	25 - 50		31.3 - 90	SPC 450	8	1027	1130	425	295	336	
	355 LB <sup>1)</sup>	22.4 - 35.5		28 - 63.9	SPC 450	8	1027	1130	425	295	336	
<b>B3.H 17</b>	315 M	63; 71	1.25 1.4 1.6 1.8	78.8 - 127.8	SPC 355	6	900	1118	380	272	227	120
	315 MD <sup>1)</sup>	50 - 71		62.5 - 127.8	SPC 400	8	900	1118	380	272	227	
	315 LB <sup>1)</sup>	35.5 - 71		44.4 - 127.8	SPC 400	8	900	1118	380	272	227	
	355 MB <sup>1)</sup>	28 - 56		35 - 100.8	SPC 450	8	900	1148	425	302	227	
	355 LB <sup>1)</sup>	25 - 45		31.3 - 81	SPC 450	8	900	1148	425	302	227	
<b>B3.H 18</b>	315 M	71; 80	1.25 1.4 1.6 1.8	88.8 - 144	SPC 355	6	900	1118	380	272	227	120
	315 MD <sup>1)</sup>	63 - 80		78.8 - 144	SPC 400	8	900	1118	380	272	227	
	315 LB <sup>1)</sup>	45 - 80		56.3 - 144	SPC 400	8	900	1118	380	272	227	
	355 MB <sup>1)</sup>	35.5 - 71		44.4 - 127.8	SPC 450	8	900	1148	425	302	227	
	355 LB <sup>1)</sup>	31.5 - 56		39.4 - 100.8	SPC 450	8	900	1148	425	302	227	

1) Loher-Baugrößen

1) Loher sizes

1) Tailles Loher

## Zahnradgetriebe

Motorstühle  
Horizontal  
Bauart B4.H  
Größen 5 - 11

## Gear Units

Motor Brackets  
Horizontal  
Type B4.H  
Sizes 5 - 11

## Réducteurs à engrenages

Châssis support moteur  
Horizontal  
Type B4.H  
Tailles 5 - 11

K20/008



Tabelle / Table / Tableau 4

Bauart Größe Type / Size Type Taille	IEC-Motor IEC motor Moteur IEC	i Getriebe i Gear unit i Réducteur	i Riemetrieb i Belt drive i Poulies	i Gesamt i Total	Riemenscheibe Motorwelle Poulies arbre moteur	Riemen- anzahl No. of belts No. de courroies	b	E	e <sub>1</sub>	e <sub>2</sub>	l
							mm	mm	mm	mm	mm
<b>B4.H</b> <b>5</b>	90 L	280; 315	1.25	350 - 567	SPZ 80	2	385	430	125	130	75
	100 LB	180 - 315		225 - 567	SPZ 100	2	385	442	125	118	75
	100 LD	125 - 180		156 - 324	SPZ 100	2	385	442	125	118	75
	112 M	100 - 180		125 - 324	SPZ 112	2	385	458	125	102	75
	132 S	80 - 140		100 - 252	SPZ 140	2	385	482	150	123	92
	132 M	80 - 112		100 - 202	SPZ 140	3	385	482	150	123	92
<b>B4.H</b> <b>6</b>	90 L	355; 400	1.25	444 - 720	SPZ 80	2	385	430	125	130	75
	100 LB	224 - 400		280 - 720	SPZ 100	2	385	442	125	118	75
	100 LD	160 - 315		200 - 567	SPZ 100	2	385	442	125	118	75
	112 M	125 - 250		156 - 450	SPZ 112	2	385	458	125	102	75
	132 S	100 - 180		125 - 324	SPZ 140	2	385	482	150	118	92
	132 M	100 - 140		125 - 252	SPZ 140	3	385	482	150	118	92
<b>B4.H</b> <b>7</b>	100 LB	280; 315	1.25	350 - 567	SPZ 100	2	322	497	125	118	78
	100 LD	250 - 315		313 - 567	SPZ 100	2	322	497	125	118	78
	112 M	180 - 315		225 - 567	SPZ 112	2	450	513	125	102	78
	132 S	125 - 250		156 - 450	SPZ 140	2	450	530	180	155	120
	132 M	90 - 180		113 - 324	SPZ 140	3	450	530	180	155	120
	160 M	80 - 125		100 - 225	SPZ 180	3	450	552	180	133	120
<b>B4.H</b> <b>8</b>	160 L	80; 90	1.25	100 - 162	SPA 180	3	450	552	180	133	120
	100 LB	355; 400		444 - 720	SPZ 100	2	322	497	125	118	78
	100 LD	315 - 400		394 - 720	SPZ 100	2	322	497	125	118	78
	112 M	224 - 400		280 - 720	SPZ 112	2	450	513	125	102	78
	132 S	160 - 315		200 - 567	SPZ 140	2	450	530	180	155	120
	132 M	125 - 224		156 - 403	SPZ 140	2	450	530	180	155	120
<b>B4.H</b> <b>9</b>	160 M	100 - 160	1.25	125 - 288	SPZ 180	3	450	552	180	133	120
	160 L	100 - 125		125 - 225	SPA 180	3	450	552	180	133	120
	132 S	224 - 315		280 - 567	SPZ 140	2	550	572	180	178	120
	132 M	160 - 315		200 - 567	SPZ 140	3	550	572	180	178	120
	160 M	112 - 224		140 - 403	SPZ 180	3	550	615	180	135	120
	160 L	80 - 160		100 - 288	SPA 180	3	550	615	180	135	120
<b>B4.H</b> <b>10</b>	180 M	80 - 140	1.25	100 - 252	SPA 250	3	550	626	250	184	120
	180 L	80 - 112		100 - 202	SPA 250	3	550	626	250	184	120
	132 S	280 - 400		350 - 720	SPZ 140	2	550	572	180	183	120
	132 M	200 - 400		250 - 720	SPZ 140	3	550	572	180	183	120
	160 M	140 - 280		175 - 504	SPZ 180	3	550	615	180	140	120
	160 L	100 - 200		125 - 360	SPA 180	3	550	615	180	140	120
<b>B4.H</b> <b>11</b>	180 M	100 - 160	1.25	125 - 288	SPA 250	3	550	626	250	184	120
	180 L	100 - 140		125 - 252	SPA 250	3	550	626	250	184	120
	132 M	280; 315		350 - 567	SPZ 140	3	454	644	180	166	120
	160 M	200 - 315		250 - 567	SPZ 180	3	454	668	180	142	120
	160 L	140 - 280		175 - 504	SPA 180	3	454	668	180	142	120
	180 M	112 - 224		140 - 403	SPA 250	3	630	709	275	316	150
<b>B4.H</b> <b>11</b>	180 L	90 - 200	1.4	113 - 360	SPA 250	3	630	709	275	316	150
	200 L	80 - 140		100 - 252	SPB 280	3	630	750	275	275	150
	225 S	80 - 112		100 - 202	SPB 280	3	630	825	275	200	150
	225 M	80; 90		100 - 162	SPB 280	4	630	825	275	200	150

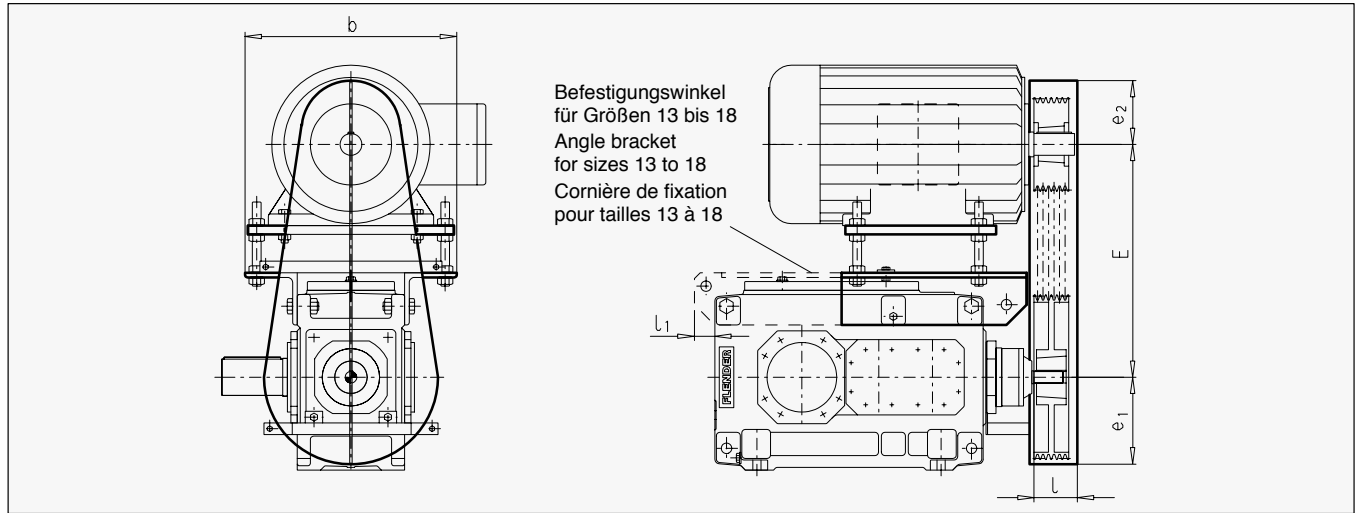

## Zahnradgetriebe

Motorstühle  
Horizontal  
Bauart B4.H  
Größen 12 - 18

## Gear Units

Motor Brackets  
Horizontal  
Type B4.H  
Sizes 12 - 18

## Réducteurs à engrenages

Châssis support moteur  
Horizontal  
Type B4.H  
Tailles 12 - 18

K20/008

Bauart Größe Type / Size Type Taille	IEC-Motor IEC motor Moteur IEC	Getriebe Gear unit Réducteur	Riementrieb Belt drive Poulies	Gesamt Total	Riemenscheibe Motorwelle Motor shaft pulley Poulies arbre moteur	Riemen- anzahl No. of belts No. de courroies	b mm	E mm	e <sub>1</sub> mm	e <sub>2</sub> mm	l mm	l <sub>1</sub> mm
<b>B4.H</b> <b>12</b>	132 M	355; 400	1.25 1.4 1.6 1.8	444 - 720	SPZ 140	3	454	644	180	166	120	-
	160 M	250 - 400		313 - 720	SPZ 180	3	454	668	180	142	120	
	160 L	180 - 355		225 - 639	SPA 180	3	454	668	180	142	120	
	180 M	140 - 280		175 - 504	SPA 250	3	630	709	275	316	150	
	180 L	125 - 224		156 - 403	SPA 250	3	630	709	275	316	150	
	200 L	100 - 160		125 - 288	SPB 280	3	630	750	275	275	150	
	225 S	100 - 140		125 - 252	SPB 280	3	630	825	275	200	150	
	225 M	100; 112		125 - 202	SPB 280	4	630	825	275	200	150	
<b>B4.H</b> <b>13</b>	160 L	224 - 315	1.25 1.4 1.6 1.8	280 - 567	SPA 180	3	575	764	250	186	125	100
	180 M	180 - 315		225 - 567	SPA 250	3	575	764	250	186	125	
	180 L	160 - 280		200 - 504	SPA 250	3	575	764	250	186	125	
	200 L	112 - 200		140 - 360	SPB 280	3	575	825	275	255	155	
	225 S	90 - 160		113 - 288	SPB 280	3	751	881	275	199	155	
	225 M	80 - 140		100 - 252	SPB 280	4	751	881	275	199	155	
	250 M	80 - 112		100 - 202	SPB 315	4	753	938	305	272	155	
	280 S	80 - 90		100 - 162	SPB 315	5	753	980	305	230	155	
<b>B4.H</b> <b>14</b>	160 L	280 - 400	1.25 1.4 1.6 1.8	350 - 720	SPA 180	3	575	764	250	186	125	100
	180 M	224 - 400		280 - 720	SPA 250	3	575	764	250	186	125	
	180 L	180 - 355		225 - 639	SPA 250	3	575	764	250	186	125	
	200 L	140 - 250		175 - 450	SPB 280	3	575	825	275	255	155	
	225 S	112 - 200		140 - 360	SPB 280	3	751	881	275	199	155	
	225 M	100 - 180		125 - 324	SPB 280	4	751	881	275	199	155	
	250 M	100 - 140		125 - 252	SPB 315	4	753	938	305	272	155	
	280 S	100; 112		125 - 202	SPB 315	5	753	980	305	230	155	
<b>B4.H</b> <b>15</b>	180 L	250 - 315	1.25 1.4 1.6 1.8	313 - 567	SPA 250	3	650	797	275	283	150	120
	200 L	180 - 315		225 - 567	SPB 280	3	650	881	275	199	150	
	225 S	140 - 315		175 - 567	SPB 280	3	650	923	305	287	155	
	225 M	125 - 250		156 - 450	SPB 280	4	650	923	305	287	155	
	250 M	100 - 200		125 - 360	SPB 315	4	820	938	305	272	155	
	280 S	80 - 140		100 - 252	SPB 315	5	820	980	305	230	155	
	280 M	80 - 125		100 - 225	SPB 315	6	820	980	305	230	155	
	315 S	80 - 100		100 - 180	SPC 355	5	820	1051	340	254	185	
<b>B4.H</b> <b>16</b>	180 L	280 - 355	1.25 1.4 1.6 1.8	350 - 639	SPA 250	3	650	797	275	283	150	120
	200 L	200 - 355		250 - 639	SPB 280	3	650	881	275	199	150	
	225 S	160 - 355		200 - 639	SPB 280	3	650	923	305	287	155	
	225 M	140 - 180		175 - 504	SPB 280	4	650	923	305	287	155	
	250 M	112 - 224		140 - 403	SPB 315	4	820	938	305	272	155	
	280 S	90 - 160		113 - 288	SPB 315	5	820	980	305	230	155	
	280 M	90 - 140		113 - 252	SPB 315	6	820	980	305	230	155	
	315 S	90 - 112		113 - 202	SPC 355	5	820	1051	340	254	185	
<b>B4.H</b> <b>17</b>	200 L	250 - 315	1.25 1.4 1.6 1.8	313 - 567	SPB 280	3	710	1001	275	214	155	120
	225 S	200 - 315		250 - 567	SPB 280	3	710	1001	275	214	155	
	225 M	160 - 315		200 - 567	SPB 280	4	710	1001	275	214	155	
	250 M	140 - 280		175 - 504	SPB 315	4	880	1031	305	284	155	
	280 S	100 - 200		125 - 360	SPB 315	5	880	1081	305	234	155	
	280 M	80 - 160		100 - 288	SPB 315	6	880	1081	305	234	155	
	315 S	80 - 140		100 - 252	SPC 355	5	880	1101	380	294	230	
	315 M	80 - 112		100 - 202	SPC 355	6	880	1101	380	294	230	
<b>B4.H</b> <b>18</b>	200 L	315; 355	1.25 1.4 1.6 1.8	394 - 639	SPB 280	3	710	1001	275	214	155	120
	225 S	250 - 355		313 - 639	SPB 280	3	710	1001	275	214	155	
	225 M	224 - 355		280 - 639	SPB 280	4	710	1001	275	214	155	
	250 M	180 - 315		225 - 567	SPB 315	4	880	1031	305	284	155	
	280 S	125 - 250		156 - 450	SPB 315	5	880	1081	305	234	155	
	280 M	100 - 200		125 - 360	SPB 315	6	880	1081	305	234	155	
	315 S	90 - 160		113 - 288	SPC 355	5	880	1101	380	294	230	
	315 M	90 - 140		113 - 252	SPC 355	6	880	1101	340	254	230	

# Zahnradgetriebe

# Gear Units

# Réducteurs à engrenages

Kragenflansch

Mounting Flange - Long Spacer

Bride surélevée

Größen 4 - 12

Sizes 4 - 12

Tailles 4 - 12

K20/012

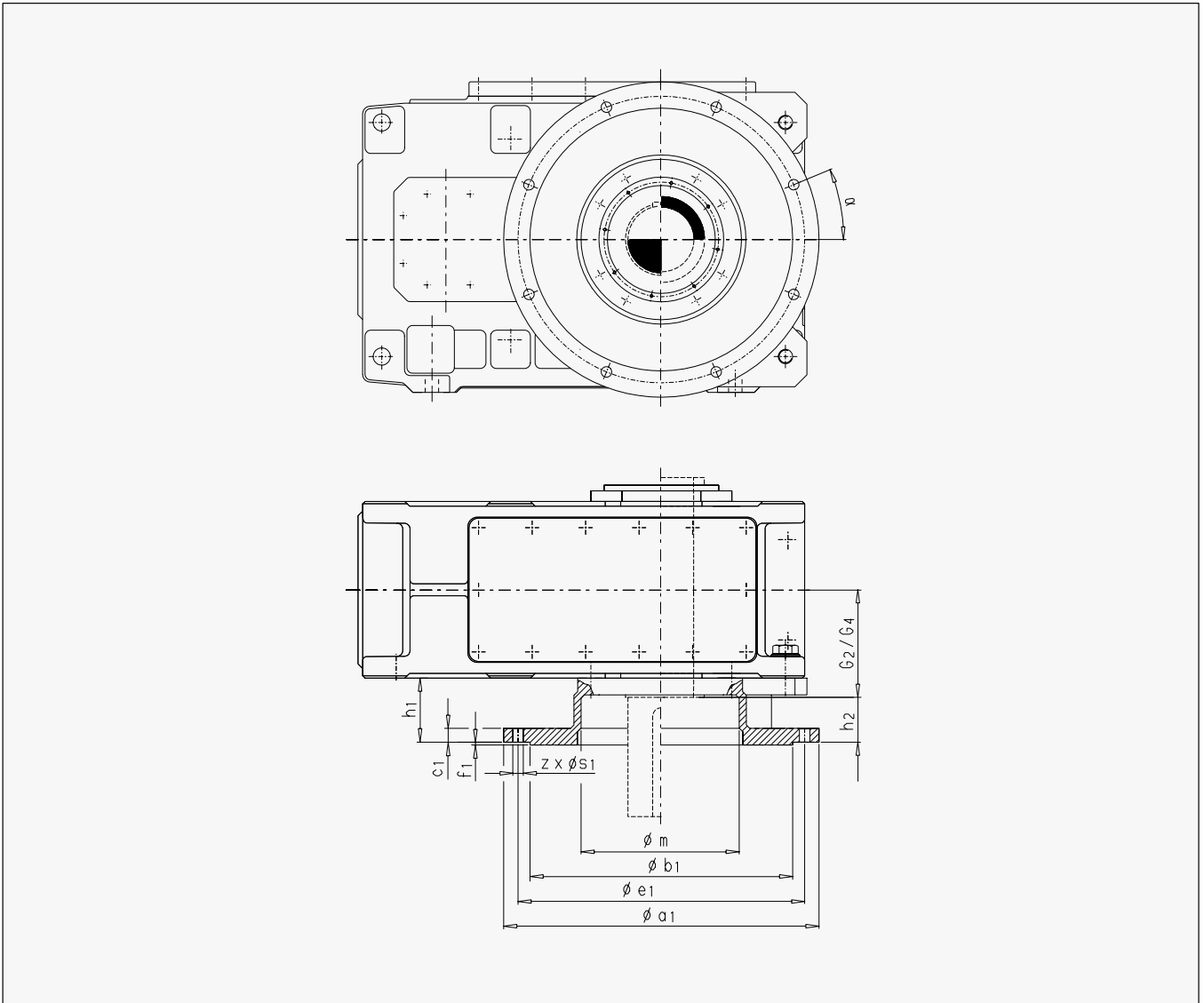

**Hinweise:**

Mögliche Ausführungsformen siehe Tabelle 3.  
 Kombinationen mit Rücklaufsperrung oder Pumpe auf Anfrage.  
 Kombinationen mit Motorlaterne oder Lüfter bei H-Getrieben der Ausführungsformen C und D auf Anfrage.

**Notes:**

For possible designs, see table 3.  
 Combination with backstop or pump on request.  
 Combination with motor bell housing or fan for H-gear units of C and D design on request.

**Indications:**

Exécutions possibles voir tableau 3.  
 Combinaisons avec antidévierneur ou pompe sur demande.  
 Moteur ou ventilateur sur les réducteurs H en exécution C et D sur demande.

Tabelle / Table / Tableau 1									
Drehmomentfaktor f / Torque factor f / Facteur de couple f									
H2., H3., H4., B3., B4..									
Faktor Factor Facteur	Größe / Size / Taille								
	4	5	6	7	8	9	10	11	12
f	1.1	1.2	1.6	1.2	1.4	1.3	1.5	1.3	1.4

B2..									
Faktor Factor Facteur	Größe / Size / Taille								
	4	5	6	7	8	9	10	11	12
f	1.0	1.0	1.3	1.0	1.2	1.1	1.3	1.1	1.2

# Zahnradgetriebe

# Gear Units

# Réducteurs à engrenages

Kragenflansch

Mounting Flange - Long Spacer

Bride surélevée

Größen 4 - 12

Sizes 4 - 12

Tailles 4 - 12

K20/012

Tabelle / Table / Tableau 2												
											H2S., H2D., H2H., H3S., H3D., H3H., H4S., H4D., H4H., B3S., B3D., B3H., B4S., B4D., B4H.,	B2S., B2H., B2D.,
Größe Size Taille 1)	a <sub>1</sub>	b <sub>1</sub> f7	c <sub>1</sub>	e <sub>1</sub>	f <sub>1</sub>	h <sub>1</sub>	h <sub>2</sub>	m <sub>max</sub>	z x s <sub>1</sub>	zusätz. Gewicht Add. weight Poids add. kg	G <sub>2</sub> / G <sub>4</sub> mm	G <sub>2</sub> / G <sub>4</sub>
mm											mm	
4	450	350	24.5	400	5	82.5	50	205	8 x 17.5	40	140	170
5	550	450	25	500	5	90	52.5	245	8 x 17.5	60	165	200
6	550	450	25	500	5	90	52.5	245	8 x 17.5	65	165	200
7	660	550	25	600	5	135	90	290	8 x 22	90	195	235
8	660	550	30	600	5	135	90	315	8 x 22	100	195	235
9	660	550	29	600	6	134	84	325	12 x 22	110	235	270
10	660	550	34	600	6	134	84	355	12 x 26	120	235	270
11	800	680	44	740	6	184	129	420	12 x 26	210	270	320
12	800	680	44	740	6	184	129	435	12 x 26	220	270	320

1)  $T_{2max} \leq T_{2N} / f$

1)  $T_{2max} \leq T_{2N} / f$

1)  $T_{2max} \leq T_{2N} / f$

Tabelle / Table / Tableau 3				
Mögliche Bauarten, Größen, Ausführungsformen Possible types, sizes, designs Types, tailles, exécutions possibles				
Größe Size Taille	H2.H	H2.V	H3.H, H4.H B2.H, B3.H, B4.H	H3.V, H4.V B2.V, B3.V, B4.V
4	A + B	B	A + B + C + D	B + C
5				
6				
7				
8				
9				
10	A + B + C + D	B + C	A + B + C + D	B + C
11	A + B	B		
12	A + B + C + D	B + C		

# Zahnradgetriebe

# Gear Units

# Réducteurs à engrenages

Blockflansch

Mounting Flange - Short Spacer

Bride

Größen 4 - 16

Sizes 4 - 16

Tailles 4 - 16

K20/012

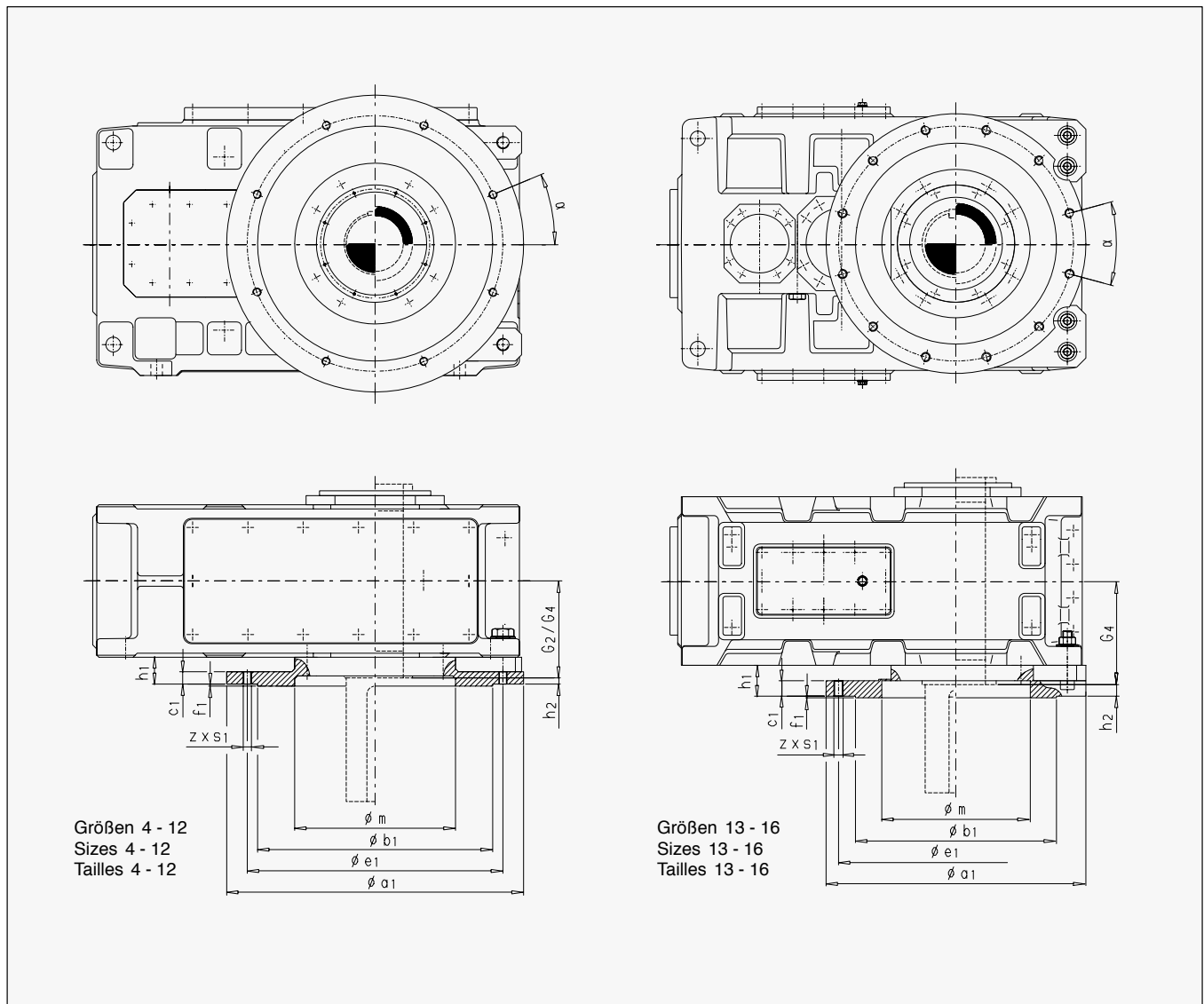

### Hinweise:

Ab Größe 13 werden nur Gehäuse ohne Fuß, d.h. in Einbaulage M eingesetzt.

Mögliche Ausführungsformen siehe Tabelle 3.

Kombinationen mit Rücklaufperre oder Pumpe auf Anfrage.

Kombinationen mit Motorlaterne oder Lüfter bei H-Getrieben der Ausführungsformen C und D auf Anfrage.

### Notes:

From size 13 up, only housings without feet, i.e. mounting position M, are used.

For possible designs, see table 3.

Combination with backstop or pump on request.

Combination with motor bell housing or fan for H-gear units of C and D design on request.

### Indications:

A partir de la taille 13 seuls les carters sans pattes (exécution M) sont utilisés.

Exécutions possibles voir tableau 3.

Combinaisons avec antidevireur ou pompe sur demande.

Combinaisons avec lanterne moteur ou ventilateur sur les réducteur H en exécution C et D sur demande.

Tabelle / Table / Tableau 1

Drehmomentfaktor f / Torque factor f / Facteur de couple f													
H2., H3., H4., B3., B4..													
Faktor Factor Facteur	Größe / Size / Taille												
	4	5	6	7	8	9	10	11	12	13	14	15	16
f	1.1	1.2	1.5	1.2	1.4	1.3	1.5	1.3	1.4	1.4	1.1	1.4	1.2

B2..													
Faktor Factor Facteur	Größe / Size / Taille												
	4	5	6	7	8	9	10	11	12	13	14	15	16
f	1.0	1.0	1.2	1.0	1.2	1.1	1.3	1.1	1.2	1.2	1.0	1.2	1.0

# Zahnradgetriebe

# Gear Units

# Réducteurs à engrenages

Blockflansch

Mounting Flange - Short Spacer

Bride

Größen 4 - 16

Sizes 4 - 16

Tailles 4 - 16

K20/012

Tabelle / Table / Tableau 2													
												H2S., H2D., H2H., H3S., H3D., H3H., H4S., H4D., H4H., B3S., B3D., B3H., B4S., B4D., B4H.,	B2S., B2H., B2D.,
Bauart Type	Größe Size Taille 1)	a <sub>1</sub>	b <sub>1</sub> f7	c <sub>1</sub>	e <sub>1</sub>	f <sub>1</sub>	h <sub>1</sub>	h <sub>2</sub>	m <sub>max</sub>	z x s <sub>1</sub>	zusätz. Gewicht Add. weight Poids add.	G <sub>2</sub> / G <sub>4</sub>	G <sub>2</sub> / G <sub>4</sub>
		mm									kg	mm	
..S. ..D., ..H.	4	445	340	25	400	5	55	22.5	205	8 x M 16	35	140	170
	5	565	430	25	515	5	60	22.5	245	8 x M 16	55	165	200
	6	565	430	25	515	5	60	22.5	245	8 x M 16	55	165	200
	7	670	530	25	620	5	60	15	295	8 x M 20	80	195	235
	8	670	530	40	620	5	80	35	300	8 x M 20	110	195	235
	9	670	530	35	620	5	80	30	320	12 x M 20	105	235	270
	10	730	560	35	680	5	80	30	355	12 x M 24	125	235	270
	11	730	560	40	680	5	90	35	400	12 x M 24	145	270	320
12	730	560	40	680	5	90	35	420	12 x M 24	155	270	320	
..S. ..D., ..H.	13	840	650	50	760	5	100	37.5	450	12 x M 30	245	335	390
240											-		
..S. ..D., ..H.	14	840	650	50	760	5	100	37.5	480	12 x M 30	255	335	390
245											390		
..S. ..D., ..H.	15	960	750	50	880	5	100	30	530	16 x M 30	315	380	460
305											-		
..S. ..D., ..H.	16	960	750	50	880	5	100	30	540	16 x M 30	320	380	460
315											450		

1)  $T_{2max} \leq T_{2N} / f$

1)  $T_{2max} \leq T_{2N} / f$

1)  $T_{2max} \leq T_{2N} / f$

Tabelle / Table / Tableau 3				
Mögliche Bauarten, Größen, Ausführungsformen / Possible types, sizes, designs Types, tailles, exécutions possibles				
Größe Size Taille	H2SH, H2HH, H2DH	H2.V	H3SH, H4SH, B2SH, B3SH, B4SH H3HH, H4HH, B2HH, B3HH, B4HH H3DH, H4DH, B2DH, B3DH, B4DH	H3.V, H4.V B2.V, B3.V, B4.V
4	A + B	B	A + B + C + D	B + C
5				
6				
7				
8				
9	A + B + C + D	B + C	A + B + C + D	B + C
10				
11				
12				
13	A + B	B	A + B + C + D	B + C
14				
15 2)				
16 2)				

2) Bauart B2.. Größe 15 + 16 nicht in Ausführung A oder C möglich!

2) Design A or C not possible for type B2..., sizes 15 + 16!

2) Type B2.. taille 15 + 16 impossible en exécution A ou C!

Explosionsschutz

Explosion Protection

Atmosphères explosives



**Explosionsschutz nach ATEX 95**

FLENDER-Zahnradgetriebe können auf Kundenwunsch in einer modifizierten, nach Richtlinie 94/9/EG zertifizierten Ausführung geliefert werden.

Diese Getriebe dürfen in explosionsgefährdeter Umgebung eingesetzt werden.

Übertageanwendungen: Kategorie 2 + 3



**Explosion protection according to ATEX 95**

FLENDER gear units can be supplied in modified design, certified according to directive 94/9/EC.

These gear units may be used in hazardous locations.

Surface application: categories 2 + 3



**Atmosphères explosives selon ATEX 95**

Les réducteurs à engrenages FLENDER peuvent être livrés (sur demande) avec une exécution modifiée (certifiées selon directive 94/9/CE).

Ces réducteurs sont utilisables dans des atmosphères explosibles.

Application de surface: catégorie 2 + 3

Beschreibung der Umgebung Description of the surroundings Description de l'environnement			Zuordnung der Geräteeigenschaften Assignment of equipment categories to safety requirements Caractéristiques du matériel		
Dauer der Explosionsgefahr: Explosive atmospheres occurring: Durée du danger d'explosion:	Explosionsgefahr durch: Explosive atmospheres caused by: Cause du danger d'explosion:		Eigenschaft: Category: Caractéristiques:	Sicherheitsanforderung: Safety requirements: Exigences de sécurité:	Sicher bei Berücksichtigung von: Safe if taking into account: Exigences de sécurité en regard de:
Die quantifizierte Angabe dient nur zur Orientierung The quantification serves for orientation only. Les données ne sont qu'à titre indicatif	Gas, Nebel, Dämpfe Gases, vapours, mists Gaz, Vapeur, Buée	Stäube Dust Poussières			
ständig, häufig, mehr als 1.000h/Jahr Continuously, frequently, for more than 1,000h/yr Permanent, fréquent, plus de 1.000h/an	Zone 0	Zone 20	Kategorie 1 Category 1 Catégorie 1	sehr hoch very high très hautes	selten auftretenden Störungen Rarely occurring disturbances Apparence rare d'interférences
gelegentlich, kurzzeitig, zwischen 10 und 1.000h/Jahr Occasionally, for a short term, between 10 and 1,000h/yr Occasionnel, à court terme, entre 10 et 1.000h/an	Zone 1	Zone 21	Kategorie 2 Category 2 Catégorie 2	hoch high hautes	üblicherweise auftretenden Störungen Normally occurring disturbances Apparence habituelle d'interférences
sehr selten, kurzzeitig, weniger als 10h/Jahr Infrequently, for a short term, less than 10h/yr Très rare, à court terme, moins de 10h/an	Zone 2	Zone 22	Kategorie 3 Category 3 Catégorie 3	normal normal normales	Bedingungen im Normalbetrieb Normal operating conditions Fonctionnement normal

Bei Getrieben in ATEX-Ausführung kann die thermische Auslegung von den in diesem Katalog genannten Parametern abweichen. Hier ist Rücksprache mit Flender notwendig!

For gear units in ATEX design, the parameters for the calculation of the thermal capacity can deviate from those given in this brochure. Please consult Flender!

Pour les réducteurs en exécution ATEX, les paramètres pour le calcul thermique peuvent ne pas correspondre à ceux indiqués dans ce catalogue. Veuillez consulter Flender!

**Zahnradgetriebe****Gear Units****Réducteurs à engrenages**

Tochterprogramme  
Informationen auf Anfrage

Subranges  
Information on Request

Programmes secondaires  
Informations sur demande

<b>Tochterprogramme</b> <b>Subranges</b> <b>Programmes secondaires</b>
Hubwerksantriebe / Hoisting gear drives / Entraînements de dispositifs de levage
Förderbandantriebe / Conveyor drives / Entraînements de convoyeurs
Fahrwerksantriebe / Travelling gear drives / Entraînements de mécanismes de translation
Becherwerksantriebe / Bucket elevator drives / Elévateurs à godets
Wasserturbinenantriebe / Water turbine drives / Entraînements de turbines hydrauliques
Kühlturmantriebe / Cooling tower drives / Entraînements de tour refroidissement
Papiermaschinenantriebe / Paper machine drives / Entraînements de machines à papier
Rührwerksantriebe / Agitator drives / Entraînements d'agitateurs
Belüfterantriebe / Aerator drives / Entraînements d'aérateurs
Bürstenbelüfterantriebe / Drives for brush ventilating devices Entraînements d'aérateur à brosses
Pulperantriebe / Pulper drives / Entraînements de pulpeur
Sichterantriebe / Separator drives / Entraînements de séparateur
Läuterbottichantriebe / Lauter tun drives / Entraînements de cuve de filtration
Sandpumpenantriebe / Sludger drives / Entraînements de pompe à sable
Einschneckenextruder-Getriebe / Single screw extruder gear units Réducteurs d'extrudeur à une vis

Die Informationen in diesem Katalog enthalten Beschreibungen bzw. Leistungsmerkmale, welche im konkreten Anwendungsfall nicht immer in der beschriebenen Form zutreffen bzw. welche sich durch Weiterentwicklung der Produkte ändern können. Die gewünschten Leistungsmerkmale sind nur dann verbindlich, wenn sie bei Vertragsabschluss ausdrücklich vereinbart werden. Liefermöglichkeiten und technische Änderungen vorbehalten. Alle Erzeugnisbezeichnungen können Marken oder Erzeugnisnamen der Siemens AG oder anderer, zuliefernder Unternehmen sein, deren Benutzung durch Dritte für deren Zwecke die Rechte der Inhaber verletzen kann.

The information provided in this catalog contains descriptions or characteristics of performance which in case of actual use do not always apply as described or which may change as a result of further development of the products. An obligation to provide the respective characteristics shall only exist if expressly agreed in the terms of contract. Availability and technical specifications are subject to change without notice.

All product designations may be trademarks or product names of Siemens AG or supplier companies whose use by third parties for their own purposes could violate the rights of the owners.

Les informations de ce catalogue contiennent des descriptions ou des caractéristiques qui, dans des cas d'utilisation concrets, ne sont pas toujours applicables dans la forme décrite ou qui, en raison d'un développement ultérieur des produits, sont susceptibles d'être modifiées. Les caractéristiques particulières souhaitées ne sont obligatoires que si elles sont expressément stipulées en conclusion du contrat. Sous réserve des possibilités de livraison et de modifications techniques.

Toutes les désignations de produits peuvent être des marques ou des noms de produits de Siemens AG ou de sociétés tierces agissant en qualité de fournisseurs, dont l'utilisation par des tiers à leurs propres fins peut enfreindre les droits de leurs propriétaires respectifs.

## **A. Friedr. Flender AG**

P.O. Box 1364

46393 Bocholt

Alfred-Flender-Strasse 77

46395 Bocholt

[www.flender.com](http://www.flender.com)

Order No. E86060-K5720-A111-A1-6300