

W22

Three Phase Motor

- Energy saving
- Increased productivity
- Extended lifetime
- Lower maintenance

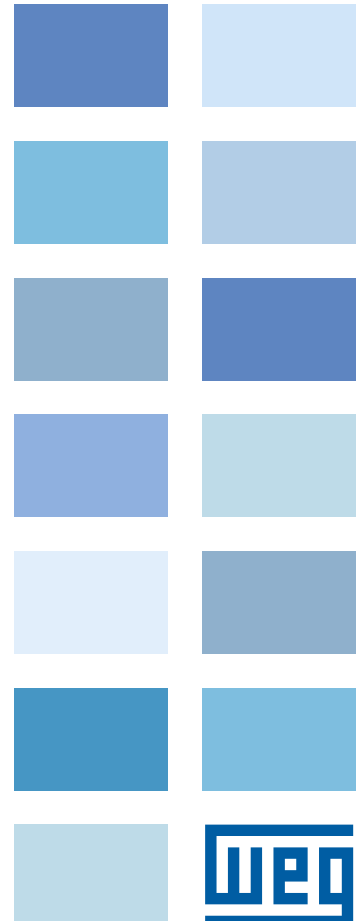
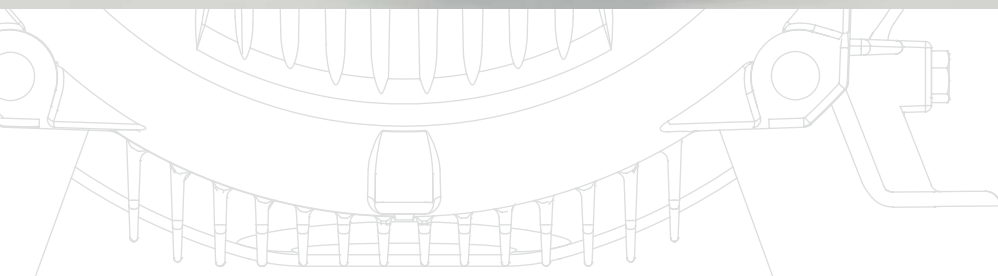
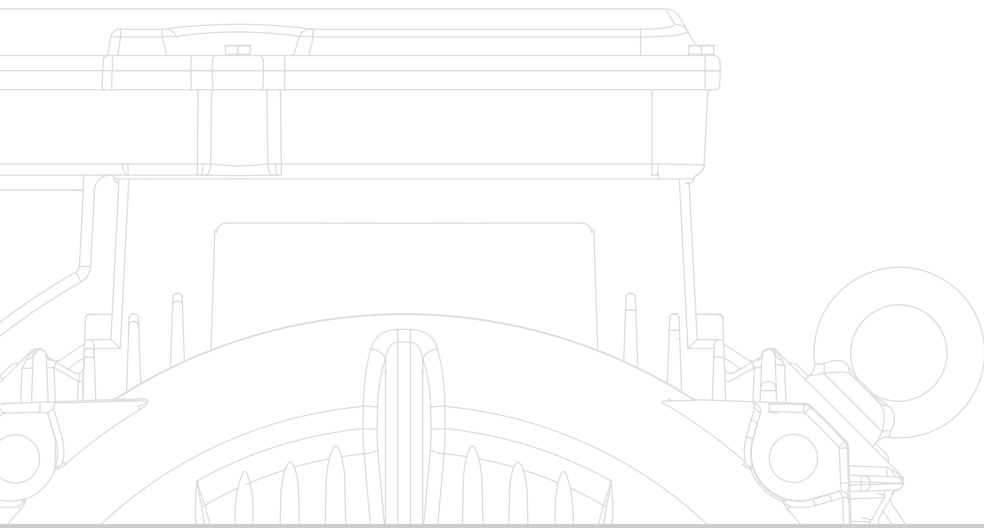

W22 The New Electric Motor Concept

High performance with maximum energy efficiency, this is the meaning of the new WEG electric motor. High efficiency and Low cost of Ownership throughout the entire motor lifetime have been the basis for the W22 development. A design created to anticipate concepts on performance and energy savings



IEC 225S/M up to 355M/L and NEMA 364T up to 587T

W22, a new concept:

- Excellent cost benefit ratio
- Optimization of energy resources
- Updated electrical features
- Noise level reduction
- Vibration level reduction
- Easier maintenance
- Improving efficiency levels

Lower total operational costs

A product that can operate the most of its designed lifetime consuming the minimum possible energy with high levels of productivity operating continuously without unplanned stops and with top performance, thus generating the maximum value to the user – this is what is behind W22 new concept.

Energy saving

Costs with energy correspond to approximately 90% of total operational costs throughout motor lifetime, being acquisition, installation and maintenance cost the other 10%. W22 new industrial motors platform are supplied with efficiencies above the EFF1 minimum required values, thus guaranteeing energy savings and reduced payback time.

Versatility

The new concept allows terminal box to be mounted top, right or left by using an extensor without disassembling the complete motor, thus reducing modification time and reducing stocks.

Built to last

W22 motors are built using high quality cast iron at WEG own foundries, assuring maximum durability and high performance in aggressive conditions. The new fan cover design provides great resistance against impacts. Additionally the endshield have been designed for a better bearing heat dissipation.

Inverter Duty applications

The exclusive WISE insulation system used on the W22 range increases windings dielectrical resistance, thus allowing VFD operation up to 575V without requiring further modification which results in flexibility and extended motor lifetime.

Range extensions for the future

The W22 platform, offering high efficiency and low lifetime costs, will be the basis for further WEG developments. For example, as well as new permanent magnet motors and Exd motors, an Eco design of compact motors with optimised materials of construction are in development offering a reduced frame size per output. WEG is confident that the principles of the W22 design are the basis for a highly successful international class of electric motors.



Aerodynamic concept to increase airflow in all motor frame

Components Design

New Cooling System

Fan Cover

- Aerodynamic concept
- Noise level reduction
- Easier assembly
- Better air flow distribution over frame
- Increase of the mechanical strength

Fan

- Reduction of fan blades
- Reinforced fan hub structure
- Noise level reduction
- Increased air flow
- Fan with higher stiffness

Frame

- Terminal box position changed
- Reduced temperature on windings and bearings
- Noise level reduction

Place for vibration sensor

- Displaced 90° from each other

Two eyebolts

- Easier handling
- Higher mechanical resistance and more handling safety

Solid feet

- More impact resistance
- Ideal for high vibrations level applications

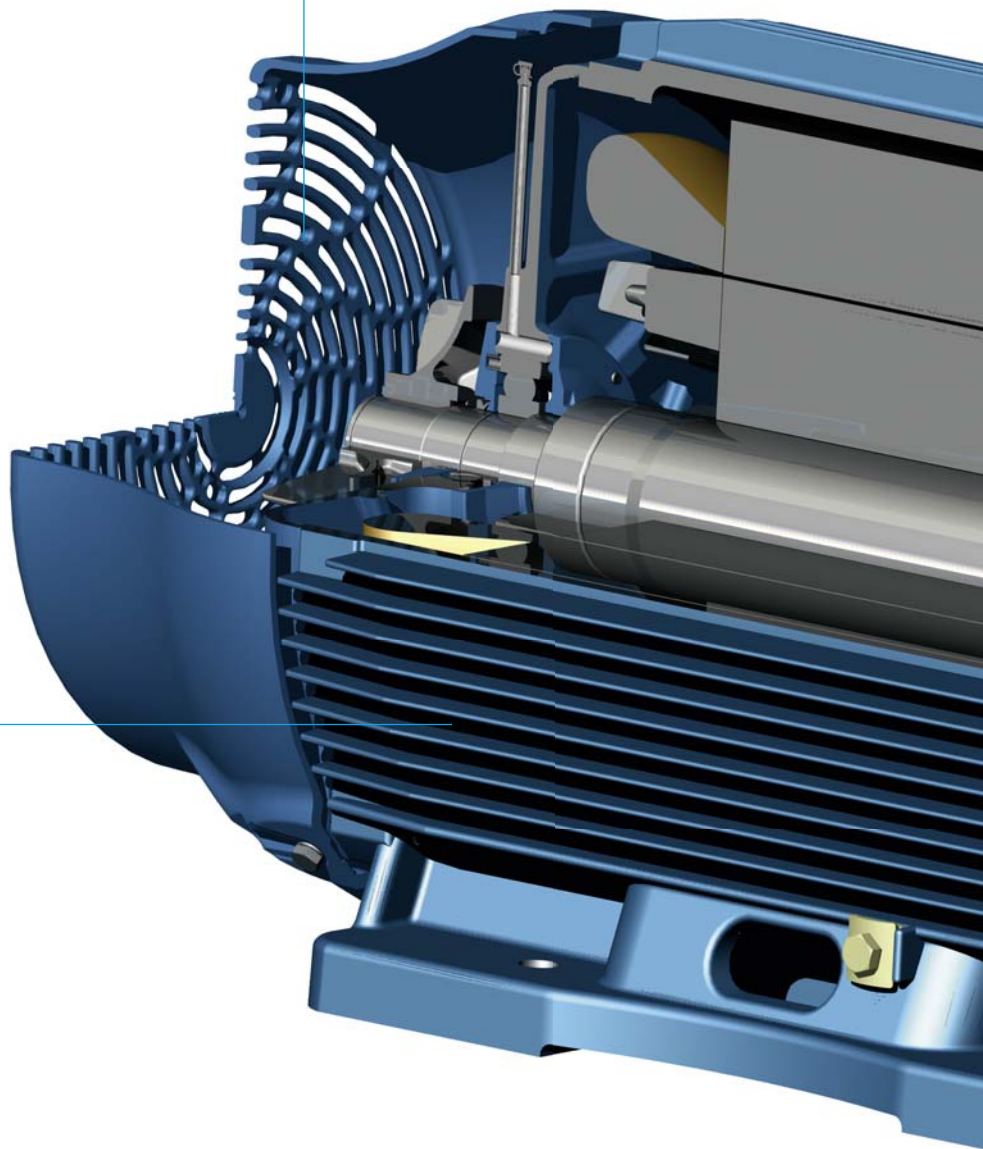

Endshields Subsystem

DE (Drive Endshield)

- New fin design
- Bearing displaced outwards the endshield
- Improved bearing heat dissipation
- Reduced bearing temperature
- Reinforced endshield structure
- Bolt protection

NDE (Non-Drive Endshield)

- New design with smooth surface
- Improved air flow
- Noise level reduction
- Structure stiffening to avoid machining deformation

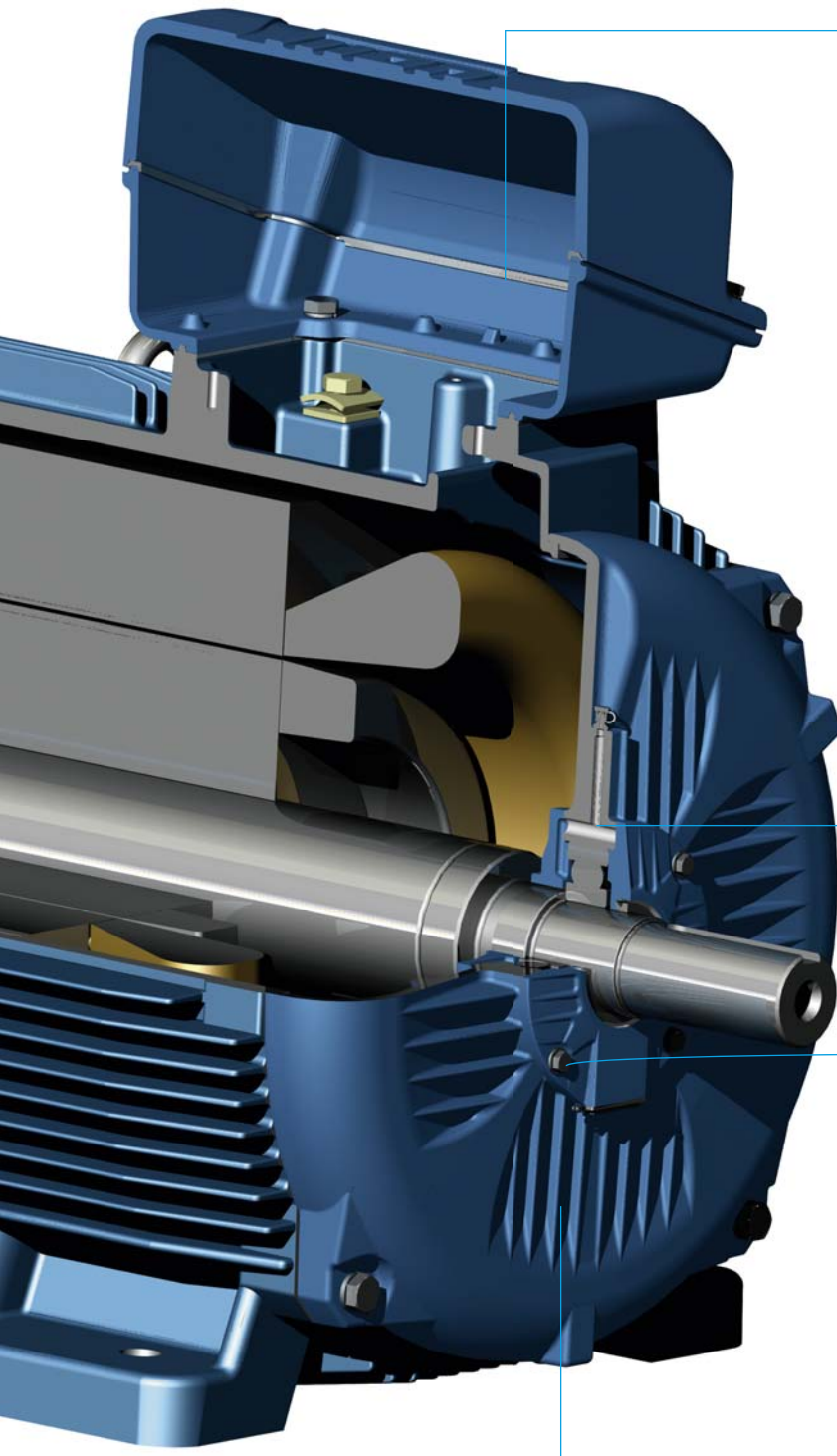

Terminal Box

- Better connection quality
- Easier cable handling during installation
- More space available for accessory installation
- Easier Maintenance

Bearing Caps

External

- Finned surface for bearing heat dissipation improvement

Internal

- Change of grease path
- Bearing lubrication quality improvement
- Reduced bearing lubrication temperature

Seal Subsystem

- Increased dust and moisture protection
- Increased protection to high-pressure cleaning



Design Details

New cooling system

Redesigned to provide improved air flow through all motor frame keeping low operational temperatures and assuring reliability and extended lifetime. The aerodynamic concept of the fan cover increases effective airflow, thus minimizing losses due to the recirculation of air between fan and fan cover. The impeller was designed to provide a tough structure and to reduce noise level. Motor terminal box and eyebolts was repositioned to allow better airflow. This new cooling system also contributes to:

- Cooler bearing temperature extending relubrication intervals.
- Lower Noise Level fulfilling the most demanding Health & Safety regulations.
- Lower Overall Operational Temperature resulting in a more efficient material usage.



Terminal box

Increased internal space and terminal block more accessible to the user reflecting in an easier cable handling and cable connection. The dimensions were optimized to provide more space to the power supply cables inlet and to auxiliary connectors resulting in easier assembly. Terminal box can be mounted on top, left or right site of the motor using the same frame.



Frame

Terminal box was placed closer to the drive end side of the motor resulting in bearing temperature and noise level reduction once the airflow is better distributed through the frame. Motor feet are solid providing a more resistant structure against vibration. The frame design has also points that can be used as provisions for vibration sensors as a standard feature.

Benefits from the new frame design:

- Motor temperature reduction
- Eyebolts repositioned - easier handling in the application.
- Provision for vibration sensors - frame and endshields with provisions 90° displaced according to maintenance technical recommendations. Easier and more reliable vibration analysis.
- Solid feet - Enhanced resistance when operating at high vibration application and also provide easier alignment on installation.



Exclusive bearing sealing system

Extends motor lifetime when operating in aggressive environments by protecting the motor against water and dust guaranteeing proper degree of protection.



WEG Worldwide Operations

ARGENTINA

WEG EQUIPAMIENTOS
ELECTRICOS S.A.
(Headquarters San
Francisco-Cordoba)
Sgo. Pampiglione 4849
Parque Industrial San Francisco
2400 - San Francisco
Phone(s): +54 (3564) 421484
Fax: +54 (3564) 421459
wegee@weg.com.ar
www.weg.com.ar

AUSTRALIA

WEG AUSTRALIA PTY. LTD.
3 Dalmore Drive
Carribbean Park Industrial Estate
Scoresby VIC 3179 - Melbourne
Phone(s): 61 (3) 9765 4600
Fax: 61 (3) 9753 2088
sales@weg.com.au
waa.weg.com.br

BELGIUM

WEG EUROPE S.A.
Rue de l'Industrie 30 D,
1400 Nivelles
Phone(s): + 32 (67) 88-8420
Fax: + 32 (67) 84-1748
info@wegeurope.be
www.wegeurope.be

CHILE

WEG CHILE S.A.
Los Canteros 8600
La Reina - Santiago
Phone(s): (56-2) 784 8900
Fax: (56-2) 784 8950
wegchile@weg.net
www.wegchile.cl

CHINA

WEG (NANTONG) ELECTRIC
MOTOR MANUFACTURING Co., Ltd.
No. 128 - Xinkai Nan Road,
Nantong Economic and
Technological Development Area
Jiangsu Province, China PC226010
Phone(s): 86 513 8598 9329
Fax: 86 513 8592 1310
www.wegchina.com

COLOMBIA

WEG COLOMBIA LTDA
Calle 46A N82 - 54
Portería II - Bodega 7 - San
Cayetano II - Bogotá
Phone(s): (57 1) 416 0166
Fax: (57 1) 416 2077
wegcolombia@weg.com.co
www.weg.com.co

FRANCE

WEG FRANCE SAS
ZI de Chenes - Le Loup
13 Rue du Morellon - BP 738
38297 Saint Quentin Fallavier
Phone(s): +33 (0) 4 74 99 11 35
Fax: +33 (0) 4 74 99 11 44
services@wegfrance.fr
www.wegfrance.fr

GERMANY

WEG GERMANY GmbH
Alfred-Nobel-Str. 7-9
D-50226 Frechen
Phone(s): +49 (2234) 9 5353-0
Fax: +49 (2234) 9 5353-10
info@weg-germany.de
wg.weg.com.br

INDIA

WEG Electric (India) Pvt. Ltd.
#38, Ground Floor, 1st Main
Road, Lower Palace Orchards,
Bangalore - 560 003
Phone(s): +91-80-4128 2007
+91-80-4128 2006
Fax: +91-80-2336 7624
weg-india@weg.net
www.wegindia.com

ITALY

WEG ITALIA S.R.L.
V.le Brianza 20 - 20092 - Cinisello
Balsamo - Milano
Phone(s): (39) 02 6129-3535
Fax: (39) 02 6601-3738
info@wegitalia.com
wit.weg.com.br

JAPAN

WEG ELECTRIC MOTORS
JAPAN CO., LTD.
Matsumoto Bldg. 2F, 3-23-7
Kamata, Ohta-ku,
Tokyo, Japan 144-0052
Phone(s): (81) 3 3736-2998
Fax: (81) 3 3736-2995
motor@weg.co.jp
wj.weg.com.br

MEXICO

WEG MEXICO, S.A. DE C.V.
Carretera Jorobas-Tula Km. 3.5,
Manzana 5, Lote 1
Fraccionamiento Parque
Industrial - Huehuetoca,
Estado de México - C.P. 54680
Phone(s): + 52 (55) 5321 4275
Fax: + 52 (55) 5321 4262
wegmex@weg.com.mx
www.weg.com.mx

NETHERLANDS

WEG NETHERLANDS
Sales Office of
WEG Europe S.A.
Keulenstraat 4E
7418 ET Deventer
Phone(s): +31 (0) 570-620550
Fax: +31 (0) 570-620560
info@weg-netherlands.nl
www.weg-netherlands.nl

PORTUGAL

WEG EURO - INDÚSTRIA
ELÉCTRICA, S.A.
Rua Eng. Frederico Ulrich
Apartado 6074
4476-908 - Maia
Phone(s): +351 229 477 705
Fax: +351 229 477 792
sales-wpt@weg.net
www.weg.net

RUSSIA

WEG RUSSIA
17, Pochainskaya Str.
Nizhny Novgorod
603001 - Russia
Phone(s): +7-831-2780424
Fax: +7-831-2780425

SPAIN

WEG IBERIA S.A.
Avenida de la Industria,25
28823 Coslada - Madrid
Phone(s) : (34) 916 553 008
Fax : (34) 916 553 058
wegiberia@wegiberia.es
www.wegiberia.es

SINGAPORE

WEG SINGAPORE PTE LTD
159, Kampong Ampat,
#06-02A KA PLACE.
Singapore 368328.
Phone(s): +65 6858 9081
Fax: +65 6858 1081
wegsg@weg.net
www.weg.com.sg

SWEDEN

WEG SCANDINAVIA AB
Box 10196
Verkstadgatan 9
434 22 Kungsbacka
Phone(s): (46) 300 73400
Fax: (46) 300 70264
info@weg.se
www.weg.se

UK

WEG ELECTRIC
MOTORS (U.K.) LTD.
28/29 Walkers Road
Manorside Industrial Estate
North Moons Moat - Redditch
Worcestershire B98 9HE
Phone(s): 44 (01527) 596-748
Fax: 44 (01527) 591-133
wegsales@wegelectricmotors.co.uk
wuk.weg.com.br

UNITED ARAB EMIRATES

WEG MIDDLE EAST FZE
JAFZA - JEBEL ALI FREE ZONE
Tower 18, 19th Floor,
Office LB181905
Dubai - United Arab Emirates
giovani@weg.net

USA

WEG ELECTRIC
MOTORS CORP.
1327 Northbrook Parkway,
Suite 490
Suwanee 30024
Phone(s): 1-770-338-5656
Fax: 1-770-338-1632
www.wegelectric.com

VENEZUELA

WEG INDUSTRIAS
VENEZUELA C.A.
Parcela T-4-A Transversal 9 Urb.
Industrial Carabobo Catastral
79-101 Edf. ELIMECA Loc.
ELIMECA, Zona Postal 2003,
Valencia, Edo. Carabobo
Phone(s): 58 (241) 838 9239
Fax: 58 (241) 838 9239
weg-wve@weg.com.ve
wve.weg.com.br



WEG Equipamentos Elétricos S.A.
International Division
Av. Prefeito Waldemar Grubba, 3000
89256-900 - Jaraguá do Sul - SC - Brazil
Phone: 55 (47) 3276-4002
Fax: 55 (47) 3276-4060
www.weg.net